

HANDBOOK
OF
*The Austin
Seven*



Publication 619

THE AUSTIN MOTOR CO. LTD
LONGBRIDGE, near BIRMINGHAM

HANDBOOK

OF

The Austin
Seven



PRICE 2/6

17th EDITION

THE AUSTIN MOTOR CO. LTD.
LONGBRIDGE, Nr. BIRMINGHAM

Telephones - - - - CENTRAL 4140. KING'S NORTON 541
Telegrams: "SPEEDILY, NORTHFIELD." Code: BENTLEY'S

LONDON SHOWROOMS, REPAIR DEPOT AND HIRE DEPT. :
479—483, Oxford Street, W.1
(NEAR MARBLE ARCH)

Telephone: MAYFAIR 6230. Telegrams: "AUSTINETTE, LONDON."

In reference to this book
please quote the number 619

A Foreword.

THE information contained in this Handbook is intended only to guide and assist owners or drivers of "Austin Seven" cars to preserve the car in its proper satisfactory running condition. This must not be considered as exhaustive or as varying or extending the liability of the company, which is limited to the Warranty issued with the car. Where no information is given for a particular adjustment, it may be regarded as one which the average owner would entrust to a garage. When the occasion for adjustments of this character arises, the owner should seek the aid of an Austin agent. Both owner and agent are encouraged to call upon the Service Department of the Company for advice, whether upon management of the car, the effecting of adjustment, or methods of repair. Owners need not suppose that they will have to apply all the attentions given in this book, but careful notice should be taken of the chapters dealing with maintenance.

Two additional publications give lists and illustrations of all the parts, and their prices, respectively, and the owner should find these books helpful for reference.

Many of the adjustments and attentions described in the following pages are included in the "Austin Seven Schedule of Charges for Repairs." The Company is confident that owners will find it to their own benefit to make the fullest use of this standard price repair and maintenance service, which it is a function of all Austin Agents to offer (see page 19).

IMPORTANT.—See special note on page 52, with reference to accessories and equipment not manufactured by the Austin Motor Co. Ltd.

February, 1928.

CONTENTS

	PAGE
AMMETER READINGS	34
ATTENTIONS, Daily	12
" Weekly	12
" Monthly	13
" Occasional	13
BATTERY, The	35
BODYWORK, Care of	49
BRAKES, Adjusting the	41-42
BRAKE GEAR, Lubrication of	30
BRAKES, Re-lining	44-45
CAR, Control of the	10
" Features of the	6
" The New	8-9
CARBURETTER, The	15-19
" " Adjustment of	15
" " Slow Running of	17
" " Leakage from	18
CLUTCH, Lubrication of	29
COMBUSTION CHAMBER, Cleaning	39-40
COOLING SYSTEM	25
DYNAMO, The	33
ELECTRICAL EQUIPMENT, The	33-37
ENGINE, Lubrication of	27-29
" Starting the	8
FAN	25, 47
FRONT AXLE, Lubrication of	31
FUSE, Action of the	35
GEARBOX, Lubrication of	29
GREASE GUN, How to use the	26
HUBS (Front and Rear), Lubrication of	31-32
IGNITION, Faults in	22
" Timing	23-24
" System, The	20-24
LAMPS, Care of	38
LUBRICATION CHART	14
LUBRICANTS, Choice of	27
MAGNETO, Lubrication of	20-21
REAR AXLE, Lubrication of	30
ROAD SPRINGS, Lubrication of	31
RUNNING ADJUSTMENTS	39-47
SHOCK ABSORBERS, Adjustment of	46
STEERING, Adjustment of	42-43
STEERING GEAR, Lubrication of	29
TOOLS, Supplied	51
TYRES, The	50
UNIVERSAL JOINT, Lubrication of	30
VALVE TAPPETS, Adjustment of	39
WHEEL, Changing a	11
WIRING, Illustration of	37

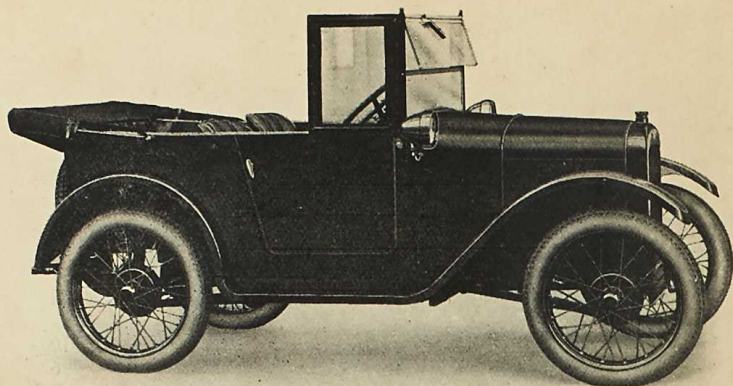

The "Austin Seven" Tourer

The "AUSTIN SEVEN"

THE "Austin Seven" is acknowledged the best small car in the world.

It is designed for, and will carry in comfort, three adults or two adults and three small children; or again it accommodates amply, two adults and their luggage up to a total weight of 30-32 stones.

There are three models made, the Tourer, the Metal Saloon, and the Fabric Saloon. The Tourer, with its easily operated hood, and side curtains that open with the doors, provides complete protection in even the most inclement weather. The Metal Saloon, is of very smart and pleasing lines, and has sliding panels in the windows making the car adaptable to all weather conditions. The particular feature of the Fabric Saloon is its wide door which allows easy ingress to, or egress from, the back seats. The door of this model carries one lifting glass panel and one sliding panel, a very convenient window arrangement.

In all models the front passenger seat tilts forward and allows ready access to the rear seats.

It has a 4-cylinder, water-cooled engine, three-speed gearbox, and bevel drive through the differential. Lubrication is by pump, and cooling is on the thermo-syphon system and by fan.

The complete equipment includes electric starting and lighting, air strangler, electric horn, speedometer, automatic windscreen wiper, license holder, shock absorbers, spare wheel and tyre and blank number plates.

Brakes are fitted to all four wheels which carry $26 \times 3\frac{1}{2}$ in. Dunlop balloon reinforced cord tyres.

The "Austin Seven" is particularly suitable for the woman driver. It requires little physical effort to drive and control, and for that reason its use enables her to do shopping calls without fatigue, visit her friends, attend social and other functions, or make excursions or trips in any direction in any weather. For the same reasons business men find it an excellent vehicle, and commercial travellers and others whose occupation compels frequent calls over an extended area, have in the little car an embodiment of all they require. Calls can be made in places where trains, trams and buses are infrequent.

In large establishments where the use of a big car for short runs with messages, on shopping, emergency calls at short notice, as in case of sudden illness, would be found costly and inconvenient, the "Seven" has proved to be a splendid "tender," saving time and money.

As 45 to 50 miles per gallon is the average petrol consumption, the cost of transit is below the cost of fares on any public conveyance, and in this particular the "Austin Seven" has no rival.

Its speed, economy, reliability and road-holding qualities have been admitted beyond dispute.

Thousands of motorists have had their first experiences on a "Seven," thousands more will follow them.

It has successfully passed through years of severe use and trial, and emerged a really successful and popular favourite.

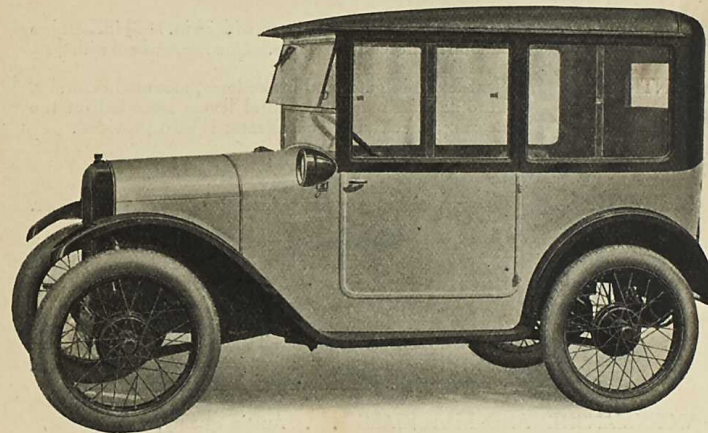

The "Austin Seven" Saloon.

ITS LEADING FEATURES

- DIMENSIONS** . . . Full car length, 9 ft. 2 in. (2,796 mm.); Full car width 3 ft. 10 in. (1,169 mm.); Wheelbase, 6 ft. 3 in. (1,905 mm.); Track, 3 ft. 4 in. (1,016 mm.); Weight, approx. 8½ cwt. (425 kg.). Ground clearance 8¾ in. (220 mm.).
- ENGINE** Four-cylinder, water-cooled detachable head.
 Bore, 2.2 in. (56 mm.) } 747.5 c.c., R.A.C. rating, 7.8 h.p.
 Stroke, 3 in. (76 mm.) }
 Brake horse-power: 10.5 at 2,400 rev.
 Ignition: Magneto.
 Oil circulation: by pump.
 Cooling: Thermo-syphon with film radiator and fan.
 Roller crankshaft bearings.
- STARTER** Electrical.
- CLUTCH** Single-plate.
- GEARBOX** Three speeds forward, and reverse; ratios: 4.9 to 1, 9 to 1 and 16 to 1; reverse, 21 to 1; Ball bearings throughout.
- REAR AXLE** . . . ¾-floating, with differential and torque tube.
 Ball bearings and thrusts throughout. Final drive by shaft and helical bevel.
- SPRINGS** ¼-elliptic cross spring in front.
 Quarter elliptics at rear.
 Shock absorbers are fitted to front and rear.
- STEERING** Worm and wheel, having provision for taking up wear.
- FRONT AXLE** . . Forged, "H" section.
- BRAKES** On all four wheels; compensated and easily adjustable.
 Hand brake to the front wheels. Foot brake to the rear wheels.
- WHEELS** Special wire detachable, fitted with 26 in. × 3½ in. Dunlop balloon reinforced cord tyres. One spare wheel with tyre.
- CONTROLS** Gear lever, in gate, and brake lever, mounted centrally.
 Throttle and magneto control levers mounted on the steering wheel. Foot accelerator is also provided.
- PETROL TANK** . . 4 gallons.
- LIGHTING** By gear-driven dynamo, with accumulators and dimmer.
- BODYWORK** Two bucket seats for driver and passenger, that for the driver being adjustable and that for the passenger being hinged to allow entrance to the rear seat. Rear seat to carry two or three children. Ample tool accommodation under seats. Spare wheel and tyre carried on back of car. Hood, double screen, and full side screens (those over the doors open with them). Electric horn, and speedometer, automatic windscreen wiper, and license holder.
- WORKMANSHIP AND MATERIALS** . . Austin quality.
- INSURANCE** . . . Special Insurance has been arranged at £8 18s. 9d. per annum.

THE "AUSTIN SEVEN" CHASSIS

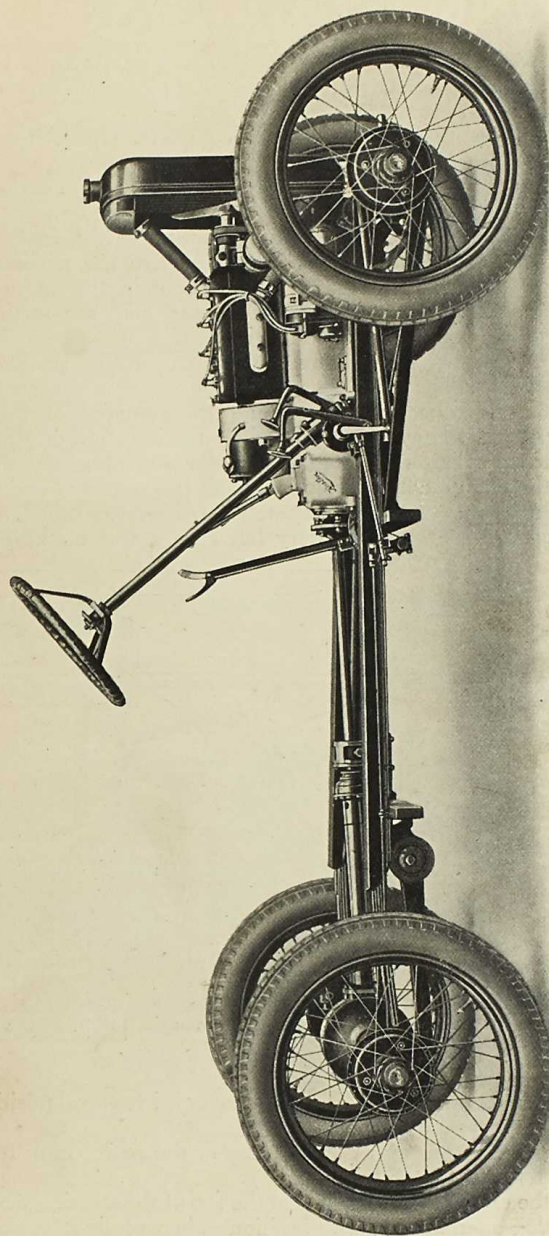

The NEW CAR

ON taking possession of a new car it is advisable to give it a general examination to see that all is complete and in order.

Make sure that the tool-kit is complete, check it over according to the list given on page 51.

If you are not already familiar with Austin cars, we strongly recommend that this handbook be carefully studied.

Before running see that the car is supplied with fuel and water and that the engine and gearbox have the necessary quantities of oil. The battery should contain the required amount of acid. For quantities of oil and acid see sections "Lubrication" and "Electrical Equipment."

Should the car be delivered by road it will be ready for running but if it has been transported by rail or overseas, the engine may have become stiff through the gumming of the oil on the pistons. They may be freed by the injection of a little petrol into the cylinders, through the compression plugs, and then turning the engine a few revolutions with the starting handle.

When a car is crated for dispatch overseas, water, fuel, and oil are removed and the battery left empty and uncharged.

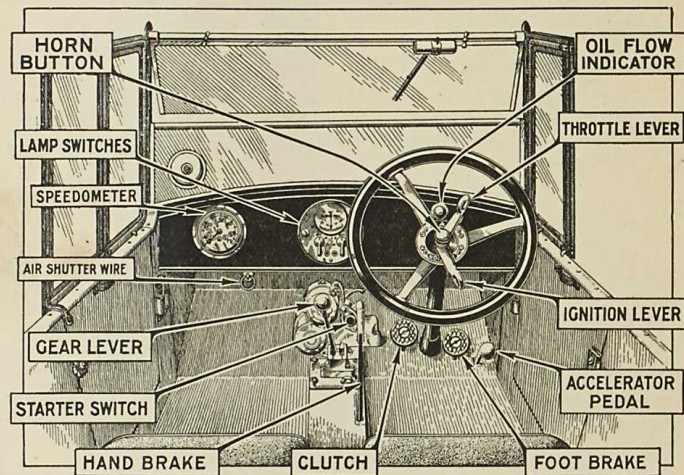

Starting the Engine

Make sure that the change speed lever is in neutral position and the hand brake on.

Turn on petrol tap at the bottom of the petrol tank (this will be found under the bonnet).

Set the engine control levers at the top of the steering wheel—Throttle—open about $\frac{1}{8}$ in. Ignition—almost fully advanced.

Give the engine a few turns with the starting handle to make sure that the crankshaft is free (pushing the handle in to engage fully with the starting nut, before turning it), then switch on, turning the left-hand switch to M. Pull out the wire on the instrument board to close the carburetter air inlet, and again give the crankshaft a few sharp turns by means of the starting handle, making

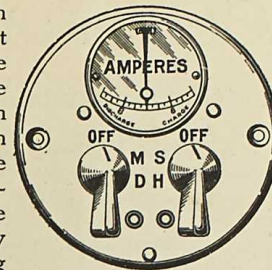

sure to pull the handle upwards to commence with, or firmly press the starter switch. *Be sure to release the air shutter wire after the engine has started.*

Do not try to start the engine when cold by the electric starter.

It is most important that the engine be not allowed to race when first starting up, as time must be allowed for the oil to circulate and lubricate various bearings.

Difficulty in Starting

Difficulty in starting may be caused either through sucking too much petrol into the cylinder, or too little. If one starts with the throttle all but closed, a strong suction takes effect on the pilot jet, and it is seldom necessary to flood the carburetter, and in any case it should only be flooded slightly. If petrol is passing through the carburetter the suction can generally be heard. If the engine fails to start and there is a good deal of petrol overflowing from the carburetter it is almost certain that the mixture getting into the cylinder is too rich. In this case open the throttle about half way. This reduces the suction effect by allowing a greater proportion of air to enter the engine. On firing, the engine may race away, but will soon settle down to steady running. If the engine does not fire close the throttle, entirely and try again. After a stop in hot weather, failure of the engine to start is more likely to be due to too rich a mixture than one too lean, and one should stop the engine by the switch only after quite closing the throttle. Re-start the engine with the throttle closed.

If after the foregoing measures have been carried out the engine fails to start the reason will probably be due to faulty ignition or carburation.

IGNITION: First examine the wires and see that the sparking plugs are connected. Then test the gap of the plug points by means of the thick end of the gauge provided in the tool kit. If the points are dirty, clean them before replacing the plug. For fuller details on the ignition system see page 20.

CARBURATION: The slow running jet may be stopped up or a main jet choked. Blow them out with a tyre pump. For fuller details about the carburetter see page 15.

The engine should never be allowed to run at high speeds for the first 300 miles.

CONTROL OF THE CAR

Setting of Control Levers

AFTER having started the engine, keep the ignition lever in the advanced position; should the engine commence to "rumble" or run roughly, retard the lever, but advance it again as soon as the load on the engine is lessened. The "gas" lever should be set generally for slow running and the speed of the car controlled by the accelerator pedal.

Changing Gear

Double declutching will be found the best method of gear changing on the "Austin Seven" and should be adopted straight away. It will be understood that when changing up the foot should be taken off the accelerator pedal, and that when changing to a lower gear it should be held down. The car should be well accelerated on each speed when changing up, and a deliberate pause should be made with the gear lever in neutral position and with the clutch in whether changing up or down. The catch below the knob of the gear lever must be raised to allow the reverse gear to be engaged.

Always change gear early on a hill; never allow the engine to labour in any gear and expect it to pick up speed on changing into a lower one when the car has nearly stopped.

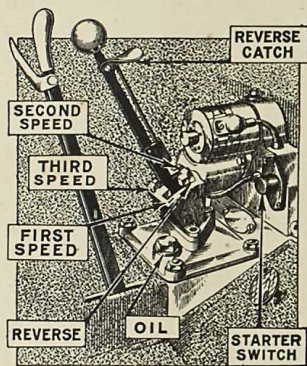

Keep the foot off the clutch pedal except in heavy traffic. Even then, do not allow the weight of the foot to be taken by the pedal. The slipping of the clutch caused by this practice heats and wears it badly.

When descending a long hill, supplement the action of the foot-brake at intervals by the use of the hand-brake for brief periods. It is often advisable to engage one of the lower gears before commencing a steep descent, with throttle closed. When using the brake, keep the clutch in, disengaging it at the last moment if stopping the car.

The driving seat of the "Austin Seven" is adjustable for position and this convenience should be taken advantage of so as to obtain the greatest comfort.

CHANGING A WHEEL

The Spare Wheel

WHEN it becomes necessary to change a wheel because of a puncture or for any other cause, the spare wheel must be lifted from its bracket at the rear of the car, to which it is fastened by three wheel nuts, in the same way as the wheels are attached to the hub.

It is important to have the car on level ground. With the wheel brace the three nuts (A) of the wheel to be removed should be slightly slackened, but only enough for them to unscrew freely later. The wheel is then jacked up. If it is a rear wheel, the jack should be placed under the rear spring anchorage on the axle (or if the car is unavoidably on uneven ground it may be advisable to block the jack up, to increase its lift).

To detach the wheel from the hub loosen the three nuts (A), by means of the brace; it is not necessary to remove them entirely. Now pull the wheel outwards about $\frac{1}{8}$ in. and turn it so that the large hole will pass over the nut. For a front wheel this can be done more easily if the hand brake is on so that the hub cannot turn. With a back wheel, if the brake cable is pulled down to put on the brake while the wheel is being detached, the movement will be similarly facilitated. The wheel can now be pulled off the hub.

When replacing make sure that the large holes in the wheel centre are properly fitted over their pegs.

Should difficulty be experienced upon the first occasion of removing the wheel from the hub, the wheel nuts may be screwed right off. Before replacing, wipe the outside of the brake drum and inside of the hub with an oily rag as this will ease the removal on future occasions.

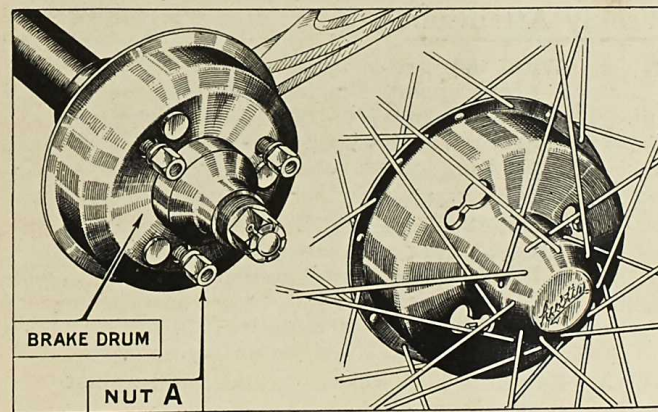

PERIODICAL ATTENTIONS

ON this and the opposite page is a handy summary of all the attentions described in this handbook. The attentions under the daily, weekly, and monthly headings are based on the assumption that the maximum mileage per week does not exceed 300.

The occasional attentions should not be neglected if the car is to continue to run efficiently. When referring to the attentions below, see the lubrication chart on page 14.

Daily Attentions

1. Examine water level in radiator and fill up to within 2 in. of the top. Always use the strainer when re-filling as dirty water will cause the radiator film to become choked.
2. Examine oil level in the crankcase and add more oil if necessary. The tell-tale dipper rod indicates the level of the oil (see illustration, page 27).
3. Fill up the petrol tank if necessary. Care should be exercised when filling the tank not to spill the petrol over the engine.

Weekly Attentions

1. With the grease gun charge—
Front spring shackle pins (4).
Rear spring pins (2).
Front wheel swivel pins (2).
Steering cross tube (2).
2. Oil the following—
Handbrake gear.
Pedal gear and jaw joints.
Engine control and ball joints.
Clutch release ring.
Rear brake cam spindles (2).
Steering side tube joints (2).
3. Examine both sets of brakes, and adjust if necessary.

4. Inject high speed grease (such as Messrs. Stern's "Diamol") into the universal joint at the rear end of the propeller shaft using the special adapter on the grease gun, and yellow grease into the front end of the torque tube.
5. Test the tyres for correct pressure and examine them for cuts (see page 50).

Monthly Attentions

1. Examine the oil level in the gearbox which should contain two-thirds of a pint, or measure 2-2½ in. deep.
2. Charge the back axle case with a gunful of grease and oil mixed half and half, using the special adapter on the grease gun.
3. Fill all the hubs with grease, as described on pages 31 and 32.
4. Charge with grease the steering worm case through the nipple.
5. Examine the battery and see that the connections are tight. For details see page 35.
6. Give a charge of grease to the nipple on the fan spindle.

Occasional Attentions

Examine all bolts and nuts, such as road spring clips, cylinder head nuts, wheel nuts (these three especially when the car is new), examine other parts such as steering connections, the radius rod anchorage below the gearbox, and the torque tube socket, neglect of which points might be followed by an expensive repair, and the inability to use the car for a lengthy period.

Occasionally clean the petrol filler and float chamber strainers, the radiator filler strainer, the oil filler strainer, and the oil reservoir gauze (when the engine oil can be changed); also ensure that the oil jets, under the plugs on the crankcase, are clean. Drain the gearbox and refill with fresh oil ($\frac{3}{8}$ pint).

Flush the radiator through. Clean the magneto distributor, and the contact breaker points (adjust the latter), the dynamo and starter commutators. Clean and lubricate the shock absorbers, adjust the tappets, and the fan belt, decarbonize the engine and grind-in the valves. Check the alignment of the front wheels. For details of these attentions refer to the pages that follow.

LUBRICATION CHART

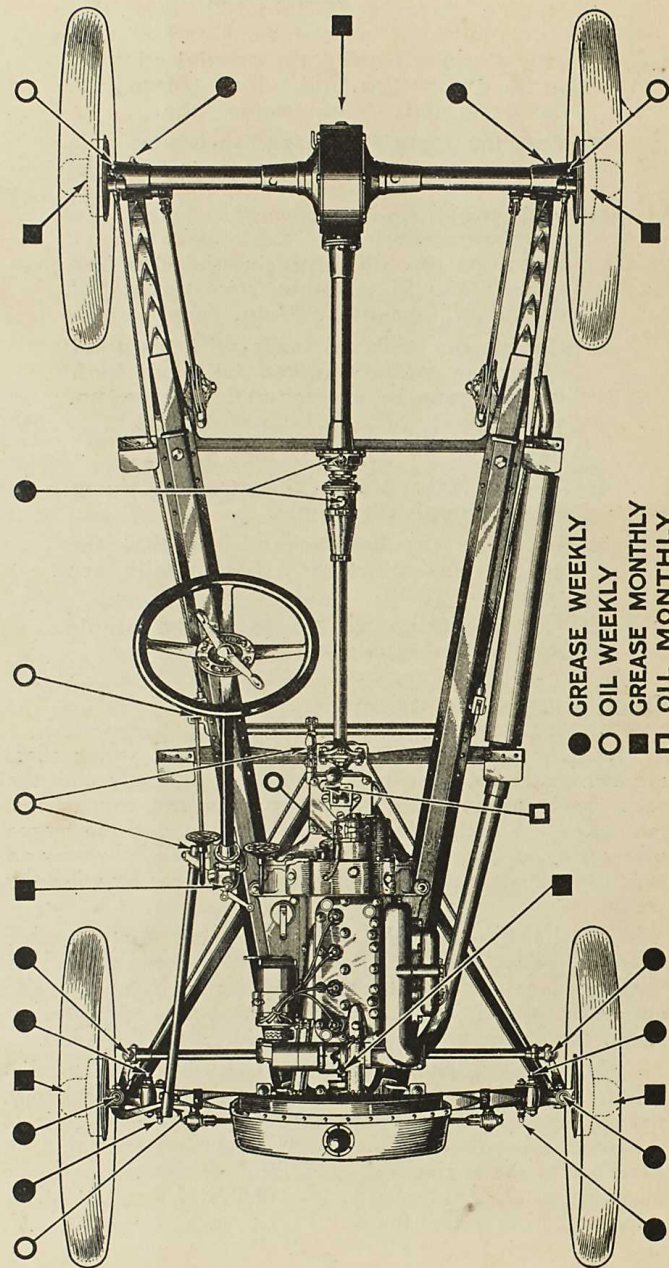

The CARBURETTER

THE following notes have reference to the Zenith carburetter, which is adjusted by determining the correct sizes of the choke tube, main jet and compensator. The purpose of the choke tube is to obtain the correct velocity of air around the jet in order to get the best mixture at all speeds. The main jet has most influence at high speeds. The compensator, which corrects the irregularities of the main jet flow due to differences in engine speed, has the greatest influence at slow speeds. Besides these three parts there is a special device to provide for slow running. The carburetter is tuned and set at the works to give the best results under ordinary conditions; should the car be taken to districts where the atmospheric conditions vary considerably, or a different fuel be used, it may be advisable to adjust the carburetter accordingly. Before making alterations to the carburetter make quite sure that the engine is in good running order particularly the ignition.

Method of Adjustment

Before altering the carburetter setting, turn off the petrol by means of the tap underneath the tank. A jet key is sent out with each car for the purpose of taking out the main and compensating jets. The caps below the jets must be removed by means of the adjustable spanner, when the jets can be unscrewed with the special key. When replacing either, make sure that they have washers on them, and are well down on the shoulder.

To remove the choke tube it is necessary to separate the carburetter from the induction manifold flange, first having disconnected the throttle and air strangler controls and the petrol pipe at its union on the float chamber. The throttle fixing screw should then be removed, allowing the throttle spindle to be withdrawn and the throttle to be lifted from the carburetter bore. On unscrewing the choke tube locking screw, the choke tube will usually fall clear if the carburetter is turned upside down; in any event a slight tap will usually loosen it. When refitting a choke tube make sure that its narrowest internal diameter is downwards, and that it beds down on the ledge round the bottom of the carburetter bore; then the locking screw can be tightened. When refitting the carburetter to the induction manifold, ensure that there is a good joint between the flanges.

Poor Acceleration

When picking up is bad, or when it is impossible to obtain a sharp acceleration no matter what size of compensator is used, the choke tube is too large. The tests for "pick-up" should be made on the level. Let the car run at a good speed, slow down slightly; then press the accelerator down sharply as far as it will go. The car should then quickly pick up its previous speed without hesitation.

If, instead of accelerating, the engine stops, try larger compensators. If, in spite of this, the picking up is not good, the choke tube is too large, in which case fit another, one or two millimetres smaller, and try again until the acceleration is perfect.

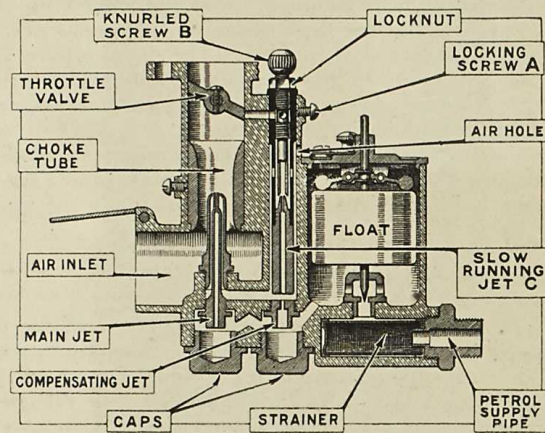

The Zenith carburettor, type 22F. The standard setting is, choke tube 15, main jet 70, compensating jet 75, slow running tube 26-35.

Lack of Speed

With too small a choke tube the pick-up is excellent but the speed attained on the level with the accelerator right down is insufficient—a larger choke tube is then fitted, and the jet altered proportionally, when the tests are continued until a satisfactory maximum speed is attained.

Choking and "Hunting"

To ascertain the correct size of the main jet, the test is also made on the level at high speed. A jet which is much too large causes choking, and the engine often runs jerkily and hunts. The petrol consumption is also excessive. The jet that gives the greatest speed on the level is chosen. If two jets give an equal speed, choose the smaller on the score of economy.

No Power

When the car gets away badly, and popping-back occurs in the carburettor when accelerating, the main jet is too small. This popping-back occurs at irregular intervals, and the engine has little power and cannot drive the car at a high speed. Fit larger jets until these explosions in the inlet pipe disappear and then test until the right jet has been found, as indicated in previous paragraph.

The popping-back may also be due to air leaking into the induction pipe through joints which are not air-tight, to leakage at the extra air valve, or to the valves not closing properly. Test the tappet clearances by the thin blade of the sparking plug and tappet clearance gauge. In some cases popping back is due to the engine being cold, and will cease when it has been running for a little time.

Irregular Firing

The trials of different compensators should take place up an incline, with the engine driving the car at a speed it can scarcely maintain, say 300 to 500 r.p.m. The compensator is too large when the engine at this speed runs with an irregular, jerky motion; the hunting which takes place at high speed in the case of too large a main jet is found at low speeds with too large a compensator. The size of the compensator is decreased until all the cylinders fire evenly and the exhaust is quite regular. As in the case of the main jet, if two compensators give equal results, choose the smaller on the score of economy. The compensator plays a great part in the picking-up, but when the size of the former is determined according to the above method, it is generally suitable for an excellent acceleration.

Slow Running Device

Note that too much petrol for slow running causes choking and hesitation in pick-up. A want of petrol, on the other hand, causes a loss of power and misfiring at the same time. It is therefore necessary to regulate the slow running as carefully as possible. By first releasing the lock nut and then turning the knurled screw B to the right a greater flow of petrol is obtained, while it can be cut down by turning the screw to the left.

This device can be drawn out after releasing the lock-nut and slackening the round-headed screw A on the side. It is possible to unscrew the lower half C, from the upper with a pair of pliers, in order to see if it is clear.

There are other factors quite apart from the carburetter which have great influence on slow running (slow running when the engine is out of gear and the car is stationary).

These factors are:—

Joints not air-tight. Valve guides worn. Valves not seating. Ignition too much advanced.

Engine Misfires and Stops

In tests made as in the last instance, the engine misses fire now and again, the transmission receives jerks, and the engine finally stops. In this case fit a larger compensator until the engine runs regularly.

The Float Chamber

Petrol leakage from the float chamber may be due to the caps under the jets not being tight, or a leaking petrol pipe union. If no leakage seems possible at these points, suspect float chamber derangement, which is causing petrol to overflow the jets. It may be that the float control is out of adjustment, the float may be perforated, or the needle not seating properly owing to dirt on the needle seating. The remedy for the last mentioned defect is obvious; the first two defects should be left to an expert to remedy. When replacing the float chamber cover, ensure that the needle has entered its seating, and is free to be moved by the float; also that the cover beds down properly, then secure it with the clip.

Petrol Flow

If the petrol supply from the Autovac is unrestricted yet difficult starting points to insufficient petrol, there is a restriction somewhere in the carburetter. First, see that the air vent in the float chamber cover, under the retaining clip, is clear. Should it be so, the next point to examine is the filter below the float chamber, and the passage from it to the needle seating. Access to this filter is given by removing the petrol pipe union and unscrewing the petrol inlet nut, on the bottom of the float chamber.

The slow running tube and jet may be stopped up. Remove the slow running tube bodily, having loosened its locking screw. In the bottom of the tube is a small filter which can be prised out and cleaned. The bottom portion of the tube, comprising the jet, may be then unscrewed from the top portion, and the jet cleaned if stopped up; two flats on the jet allow a small spanner to be used to unscrew it. Lastly the compensating or main jets may be choked. Remove them and clear them. Never insert anything in any of the jets; always blow through to clear them; a tyre pump can be used if desired. When refitting the slow running tube ensure that it beds down to its collar at the top, with the small projection under the collar fitting the groove in the carburetter casting; then tighten the locking screw.

Difficulty in Starting

This may be due to several causes—

Float chamber air vent stopped up (see previous page).
Slow running tube stopped up (see previous page).
Plug points too far apart. See "Ignition System."
Ignition lever badly placed. See next paragraph.
Jets choked up (see previous page).

With variable ignition there is generally a particularly favourable setting for easy starting. One who is continually using a car soon recognises this position.

STANDARD REPAIR CHARGES

THE following adjustments and repairs described in this handbook are included in the "Austin Seven" Schedule of Charges for Repairs, which quotes over ninety prices for repairs to the "Austin Seven." Owners will find it to their advantage to have their car adjustments and repairs effected by Austin agents at these standard prices.

Greasing spring shackles, steering and brake, and other small connections.

Ditto, but including rear axle, universal joint, steering box and front hubs.

Taking down, cleaning and greasing all road springs, reassembling with new bolts and bushes where required.

Dismantling shock absorbers, then cleaning and adjusting and refixing.

Adjusting and compensating brakes.

Relining brakes, front or rear.

Removing cylinder head; decarbonising and grinding in valves: adjusting tappets and tuning-up engine on the road.

Fitting new cylinder head and/or gasket.

Adjusting valve tappets, cleaning and adjusting contact breaker, distributor and sparking plugs; cleaning out carburetter jets.

Fitting new valves.

Removing base chamber, cleaning oil filter, examining interior of engine, and refilling with new oil.

Removing dynamo from car; cleaning and adjusting, examining battery and connections, and refilling battery with acid as required.

Tracking up front wheels by adjusting length of cross steering tube.

Adjusting mesh of steering worm and wheel.

The IGNITION SYSTEM

THE following remarks are common to all magnetos other than the M.L., particulars of which are given overleaf.

The magneto requires very little attention, and the only adjustment necessary is that of the gap between the platinum points (A and B) of the contact breaker. The correctness of this gap is tested by the gauge on the side of the magneto spanner. Too great a gap will advance the timing and cause wear on the points. The adjustment is made by turning the screw (B) after releasing the lock-nut (C). Tighten the lock-nut again when the adjustment has been completed. Keep the points free from oil. Should they become ragged have them trimmed lightly with a dead smooth file by a skilled man.

THE CONTACT AND BREAKER DISTRIBUTOR

- A Fixed platinum point.
- B Adjusting screw.
- C Lock-nut.
- D Cam cage ring.
- E Bell crank retaining strip.

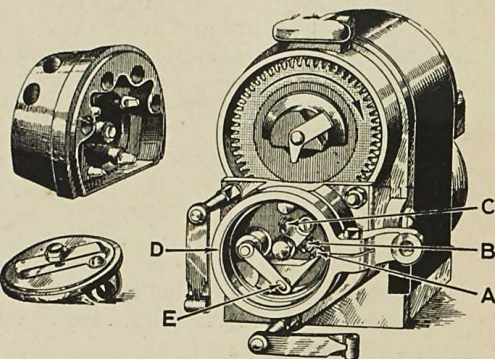

If necessary, the whole of the contact breaker can be removed, though adjustments to the points can usually be effected with it in position. To detach, remove the cam ring (D), unscrew the central nut with the small special spanner provided. In replacing the contact breaker care must be taken to see that the projection on the taper portion of the contact breaker base engages with the keyway cut in the armature spindle, also the hexagon securing screw must be absolutely tight, otherwise sparking at the points and erratic running of the magneto will occur. Lift the end of the retaining strip (E) when the bell crank can be withdrawn.

The distributor and brush holder require attention. Remove the distributor and clean inside it with a cloth soaked in petrol. Any dust or foreign matter that may accumulate inside the distributor is liable to cause leakage, the symptoms of which are misfiring or poor starting. In a similar manner wipe the surface of the brush holder, particularly between the safety gap electrodes. Oil the magneto with about eight drops of thin oil through the lubricator in the top, every few thousand miles.

THE M-L MAGNETO

The standard M.L. magneto is designated type R.F.4. Full information for its upkeep and maintenance are given in the maker's instruction book, and for convenience are briefly summarised below.

Care and Maintenance

The magneto is fitted with ball bearings with the exception of the distributor shaft. The ball bearings are packed with a high melting point grease and require no further lubrication. The distributor shaft should be lubricated every 1,000 miles with a few spots of thin oil at A. Do *not* use a heavy oil such as engine or cylinder oil. Sewing machine oil is very suitable.

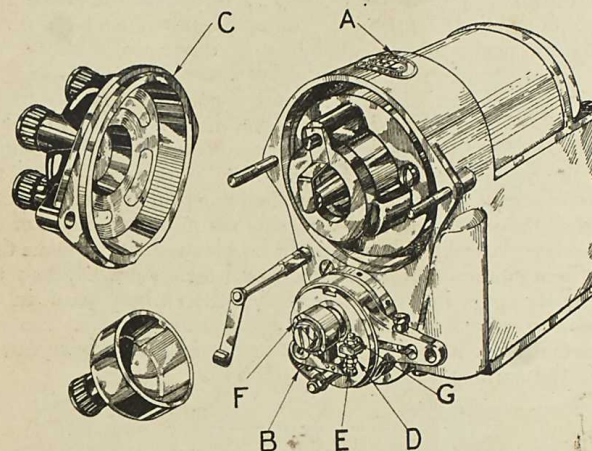

A—Lubricator. B—Contact Breaker Spring. C—Distributor.
D—Adjustable Point. E—Fixed Point. F—Cam. G—Locking Nut.

The Contact Breaker

The contact breaker should be examined occasionally. See that the points (D,E) separate the correct distance when opened by the cam (F). Check this with the gauge fitted to the magneto spanner supplied with each magneto. After adjusting, make sure that the point (D) is properly locked by the nut (G).

Should the cam or fibre block appear dry and dusty, or should there be any tendency to squeak when the engine is running slowly, apply a touch of oil to the cam surface on the point of a pencil or the end of a match stalk. Do not give any excess as it may get on the points. Also about every six months place a spot of oil on the end of the contact breaker pivot pin so as to lubricate the bearing.

Take care not to let the contact spring get rusty, as rust is almost certain to lead to breakage. Any sign of rusting should be checked at once.

Do not attempt to run with a very large gap between the contact points. They wear more rapidly and the machine will be less efficient, because the armature will not be in the best position when the circuit is broken.

Spark Gap

Do not use any form of amplifier or spark gap in connection with the magneto. No improvement will be obtained, and its use may lead to high voltages and possible breakdown.

Insulating Surfaces

As wet and dirt on insulation will often cause leakage and bad starting, it is advisable to keep the outside of the distributor, to which the H.T. cables are connected, reasonably clean and free from accumulation of dirt and dust. In addition the distributor should be removed about every 5,000 miles and the interior wiped out with petrol and a soft rag. As the R.F.4 magneto is of the revolving field type there is no brush holder and slip ring at the other end of the magneto to require attention and the whole of the H.T. insulation is exposed when the distributor block is removed. If the insulation of the distributor rotor, or the insulating bush, passing through the centre of the gear wheel, are dirty these should be cleaned, at the same time care being taken not to damage or break them. When the distributor cover is removed, examine the carbon brush in the distributor rotor, making sure that it slides freely. Do not remove it from its guide unnecessarily, and take care not to strain the spring.

TROUBLES AND REMEDIES

IRRREGULAR firing or faulty ignition may be traceable to slight defects in the magneto or carburetter. A partially choked jet, or an incorrect petrol level, may be the fault. Air leaks in the induction system are a possible cause of bad starting and irregular running at low speeds.

For faulty ignition. First examine the sparking plugs and test the gap of the plug points by means of the thick blade of the sparking plug and tappet clearance gauge provided in the kit. If the points are dirty, clean them before replacing. A sudden failure of the ignition may result from the short circuiting of the switch cable attached to the terminal on the inspection cover of the contact-breaker. This can be readily detected by disconnecting this cable from the terminal, when the engine should fire properly.

TIMING THE IGNITION

Should it become necessary to re-time the magneto, it is as well that the operator should know that the magneto on the "Austin Seven" is coupled up to its driving shaft by means of a patented drive—which provides extremely fine adjustment, so that the magneto can be correctly timed.

The Magneto Coupling

This drive (see sketch) consists of a rubber disc (E) with teeth moulded on its faces which mesh with teeth on the coupling of the driving shaft on the one side, and teeth on the coupling attached to the magneto spindle on the other side. Now there are twenty teeth on the driving shaft side (F) but only nineteen on the magneto side (G); therefore by drawing back the magneto, disengaging its coupling from the rubber disc, then taking the disc away from the teeth on the driving shaft coupling and turning it (the disc) round one tooth, re-engaging with driving coupling, and then sliding the magneto back to its place the magneto is only moved relatively to its driving shaft by $1/20$ th of $1/19$ th of a revolution, or $1/380$ th.

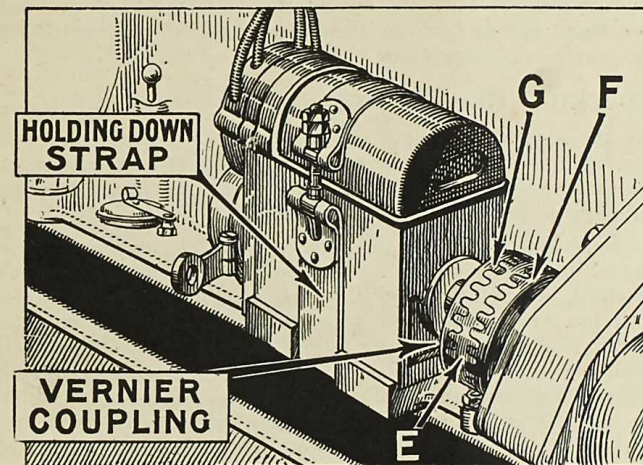

We will now proceed to explain the method of timing the magneto.

Remove all sparking plugs except the front—No. 1—and turn the crankshaft by the starting handle until compression is felt. This means that No. 1 cylinder will be the next one to fire.

Remove the starter motor with its casing by unscrewing the securing studs, one on each side of the casing, and lifting the assembly clear vertically off the locating dowel on the crankcase. A line will be seen on the back of the flywheel, marked 1 and 4 (see illustration on page 29). This line is parallel to the throws of the crankshaft, and when this line is vertical it naturally follows that Nos. 1 and 4 pistons are at the top of their stroke. In this case, however, we are only dealing with No. 1. Now turn the flywheel until this line is $1\frac{5}{8}$ in. to $1\frac{7}{8}$ in. before the top centre. This is the position at which the spark should take place at the sparking plug, when the ignition is fully advanced.

Now fully advance the ignition lever at the top of the steering wheel. Disconnect the contact breaker control and magneto strap, draw back magneto to disconnect the coupling. Turn the spindle by hand until the carbon brush of the distributor is on the segment corresponding to the magneto lead of No. 1 cylinder, and *carefully leave it* so that the points of the contact breaker are just commencing to separate. This is the position where the spark takes place.

Now hold the rubber disc in between the driving shaft and magneto, and slide the magneto towards its place—*without having turned the spindle*—leaving just sufficient room for the rubber disc to be turned round, without being in engagement on either side. Turn the rubber disc until the teeth on each side come exactly opposite those they mesh with. Then push the magneto up into place.

Checking the Timing

If nothing has moved while this latter part of the operation has been taking place, the magneto should be correctly timed, but as it is extremely difficult, without making use of the fine adjustment, to do this, the timing should now be checked.

Turn the engine round two revolutions, bringing No. 1 piston into its firing position again, and set the line of the flywheel, as before described. Check the contact breaker. If it has not commenced to open, the timing is late. The timing is advanced by drawing the magneto back, without revolving it; detaching the rubber disc from both sets of teeth and turning it one tooth in the opposite direction to that in which the magneto revolves—which in this case means turning the top of the disc towards the operator as he stands at the offside of the car. This, as before described, will advance the firing point of the magneto, relative to the driving spindle, $1/380$ th of a circle. Check and if still timed late, advance still further.

To retard, the coupling will be turned one or more teeth, as required, in the opposite direction.

The order in which the cylinders fire is, from the front, 1—3—4—2.

The COOLING SYSTEM

THE cooling of the engine is maintained by a capacious radiator which should be filled, with rain water, if available, up to within 2 in. of the top of the filler. The capacity of the radiator, pipes and cylinder jackets is 9 pints.

In Cold Weather

Care should be taken to see that the water is drained off completely, for, in case of freezing, it will do harm by lodging in small spaces and fracture of the cylinder block may result. In Great Britain, the climate does not very often call for the cooling system to be drained, but it is well to err on the right side and take due precaution against damage if frost be threatened.

Glycerine mixed with the water will reduce its freezing point by several degrees. It should be added in the proportion of 15% to 20%. In cold weather use the Austin radiator muff.

To prevent the gradual formation of deposits in the cooling system, with consequent impeding of the circulation, the use of hard water should be avoided. Rain-water, syphoned from the top of the barrel where it is clean, should be used, or, failing that, water that has been boiled.

Causes of Overheating

Overheating may be attributed to one or more of the following:

Slack fan belt: the belt can be tightened by turning the fan spindle in its bracket after loosening the clamping-nuts. Excessive carbon deposit in cylinders. See "Running Adjustments."

Running with ignition too far retarded.

Using oil of poor quality, or lack of oil in the reservoir. See "Engine Lubrication."

Partial choking of the oil jets. See "Engine Lubrication." Improper carburetter adjustment, giving a mixture too rich or too weak. See "The Carburetter."

Failure of water to circulate, because of choked radiator tubes, water level below the tops of the radiator tubes, or loss of water through leakage from connections.

Overcooling is almost as bad as overheating. If the engine tends to be too cool, use a radiator muff, or possibly, in winter, the fan belt can be removed without the engine running too hot.

The entire circulating system should be thoroughly flushed out occasionally. To do this open the drain tap at the bottom, place a hose in the filler, and run fresh water through.

Trouble arising from a damaged radiator generally necessitates its dismantling and despatch to a repair depot.

HOW TO USE THE GREASE GUN

Screw the handle right out. Unscrew the extension piece by the knurled nut at the base of the barrel and fill the barrel with grease; then replace. Give the handle one complete turn: this fills the telescopic extension piece at the end of the gun which will project. Now place the end of the gun on the nipple attached to that part of the car which it is desired to grease, and push. The extension piece closes and discharges the grease into the nipple.

Give the handle another turn and the gun is once more charged. Continue until the barrel is empty and then refill.

For the rear universal joint and the back axle a special adapter is used on the gun in place of the standard telescopic end. This adapter screws into the part to be greased, in place of the plug. When replacing the plug, do not omit its washer. It is important not to let dirt get into the adapter which, when not in use, is screwed onto the side of the gun.

DON'T!

Don't, please don't—

- Don't leave the car in gear with the handbrake off.
- Don't make a fast run with the radiator muff down.
- Don't fill the radiator with cold water when the engine is hot.
- Don't try to turn the engine without first pushing the starting-handle in to engage fully with the starting nut.
- Don't be cruel to the starter if the engine will not fire.
- Don't touch the reverse catch when changing gear.
- Don't put an excessive quantity of lubricant in the gear box.
- Don't pour oil into the engine with the strainer removed.
- Don't forget the ignition switch when starting up.
- Don't run the engine in a closed garage. (The exhaust gases are highly toxic and a very small amount in a restricted atmosphere will produce grave, if not fatal, results.)

LUBRICATION

Choice of Lubricants

FOR the engine or gear box use one of the following oils:— Stern's "Sternol W.W." Heavy; Price's "Motorine C."; Speedwell "Sans Egal Zero"; "Triple Shell"; "Mobiloil BB."; "Speedolene B. Heavy"; Texaco "Heavy"; Filtrate "Extra Heavy"; "Royal Snowdrift 3"; Wakefield's "Castrol XL"; and Duckham's "Adcol NP 3 and 4."

Use ordinary "engine" oil in the small can, and ordinary yellow grease for greasing.

Both these lubricants can be obtained from any garage or repair shop.

Use "High Speed" grease for the rear universal joint of the drive shaft.

The Engine

When the new car is sent out the engine and gearbox is filled with "Sternol W.W. Heavy" to the proper level. On no account must different brands of oil be used in the engine at the same time or mixed in any way. If the oil is too thick it will tend to clog and carbonise, and if too thin it might lead to scoring of the pistons and bearings. Assurance that oil is continuously circulating is given to the driver by means of the tell-tale button on the instrument board, which protrudes when the oil is circulating.

It is essential that all receptacles for oil be kept perfectly clean. Dirty oil

leads to undue wear of all bearings, or might even clog up the oiling system and prevent it working, thus causing an engine seizure and much trouble and expense. The oil filler strainer (A) is detachable for cleaning. After the first 500-800 miles running, drain the original oil from

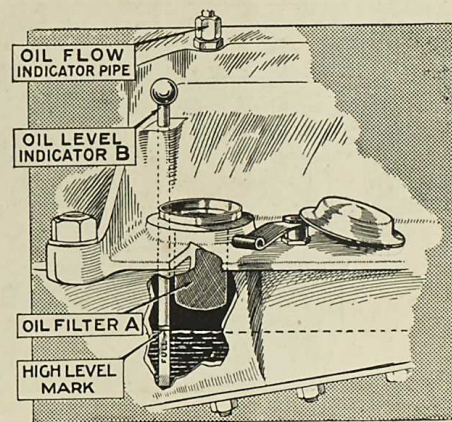

the reservoir by removing the plug in the bottom, while the engine is hot. Drain the reservoir completely. Never pour oil into the engine except through the strainer.

After the first re-filling it is advisable to change the oil in the engine entirely after every 1,200 to 1,500 miles running or sooner.

Every 2,400—3,000 miles remove the oil reservoir. The gauze oil tray will then be accessible for removal. Carefully clean the gauze and remove all dirt from inside the reservoir and replace them. Carefully remake the joint with the packing washer, covering both sides of it with grease. When tightening up the nuts holding the oil reservoir to the crankcase, do not pull up one nut tight, but tighten each nut equally, a little at a time. See that the drainplug is screwed up tight, then fill the crankcase with oil to the maximum level as shown on the dipper rod, B. About half a gallon will be enough to fill.

Always inspect the level of the oil and add, enough to fill, to the correct level before starting on a long journey.

The oil level should not be allowed to go below $\frac{1}{4}$ inch on the bottom of the dipper rod. It is advisable to wipe the dipper rod before taking the reading of the level, and the reading should only be taken when the engine is not running and the car is on the level ground.

The main bearings of the engine are of the roller type, and the oily vapour in the crankcase is quite sufficient to lubricate these.

The pistons are also lubricated by the oily vapour.

Lubrication of the big-ends is effected by catching oil from the pump-fed jets in pockets on the crankshaft webs.

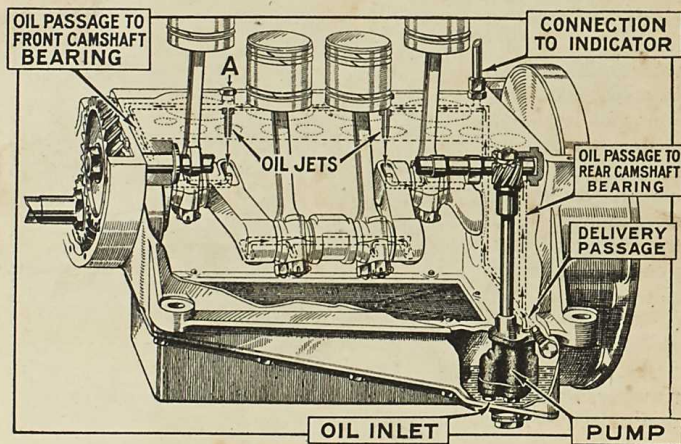

It is advisable to make sure these jets are always clear and to do so the plugs over the jets (see illustration) should be occasionally removed and a piece of stiff wire, not above $\frac{1}{16}$ in. diameter, inserted through the jets. This prevents foreign matter accumulating in the jets and choking them.

Gearbox

A suitable oil for the gearbox is the same as that used in the engine; but if for any reason another brand of oil is used it should be of about the same consistency and no thicker, otherwise it will not reach all the bearings. The depth of the oil should never be less than 1 in. or more than $2\frac{1}{2}$ in. It can be measured by a rod inserted through the filler plug hole. The maximum quantity is approximately $\frac{2}{3}$ pint. The correct oil level should be maintained; excess of oil will leak from the bearings and seriously affect the clutch, causing it to slip; on the other hand there must be sufficient oil to prevent wear.

The gearbox should be drained entirely after the first 500-800 miles, and then after every 4,000 or 5,000 miles, when any grit, etc., which may have collected will drain away through the plug hole in the sump.

The gearbox drain plug holds the clutch pit drainhole cover in position and this should be replaced when the drain plug is refitted.

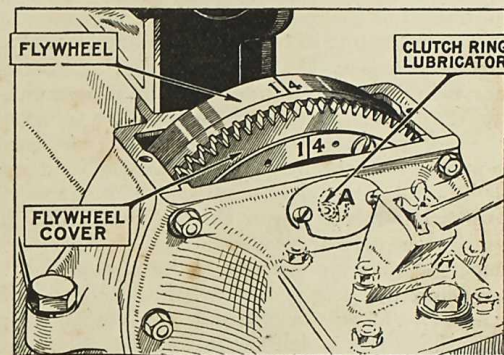

Clutch

The clutch surfaces being of a fabric material must be kept free from oil and grease, or the clutch will fail to grip. It is necessary to lubricate the operating ring at point A, as shown on the sketch, once a week with oil.

Steering Gear

To obtain easy steering it is important to give it regular attention as regards lubrication. The grease gun nipple is on the top of the worm case, and if a charge is given once a month it is sufficient to lubricate the bearings of the worm and worm wheel and also lubricate the worm itself. The bearing at the top of the column, just under the steering wheel can be given a little oil from the oil-can. The steering connections on the side rod are best lubricated by means of an oil-can which ejects the oil under pressure, into the sockets, and the nipples at the end of the cross rod should be given a charge of grease once a week.

Rear Axle

For the rear axle, attention every 1,200 to 1,500 miles should be sufficient. A mixture of yellow grease and engine oil of equal parts should be used. It is injected into the axle, using the special adapter on the grease gun barrel (in place of the telescopic end) which screws into the centre casing of the axle when the small plug has been removed with a $\frac{5}{16}$ in. box spanner. The gun handle is screwed down to inject the grease. When replacing the plug see that the washer is not omitted. Do not inject too much grease at any one time as the felt rings will fail to hold this grease in the axle case, and it will then leak through on to the brake drums and prevent them from being effective.

Rear Universal Joint

For the rear universal joint a good quality "high speed" grease should be used. This is of a dark brown colour, and will remain in the joint longer than the ordinary yellow grease.

The rear universal joint being of metal must be kept well lubricated at (A) on account of the movement of the rear axle. It should be one of the points to have strict attention. The grease gun is used with the special adapter screwed on the barrel in place of the standard telescopic end, as described for the rear axle. The small cover in the top of the centre floor channel, just between the seats, must be removed. The car is moved until the plug in the universal joint is facing upwards (if it is not already so), and a $\frac{5}{16}$ in. box spanner is necessary to unscrew the plug from the universal joint. The adapter on the grease gun is screwed in, in place of the plug, and the grease injected by screwing down the grease gun handle. After greasing the plug is refitted, the washer under it not being omitted. Access for greasing this, together with the grease connection (B), which should receive yellow grease weekly on the end of the torque tube, is obtained through the cover (C) in the floor of the body, as shown on the illustration adjoining.

Brake Gear

On each of the rear brakes there is a lubricator for oiling the cam spindle bearing. These and all other joints, etc., should be oiled once a week.

The front brake cam spindle is lubricated from the swivel pin as shown at (B), in the illustration overleaf.

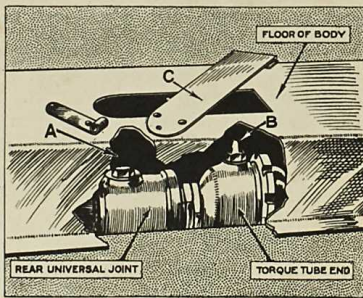

Front Axle

The swivel pins are lubricated with the grease gun and should receive attention once a week.

Radius Rod Anchorage

Oil should be applied occasionally to the cups and ball flange, forming the radius rod anchorage on the front cross member, just below the rear of the gearbox.

Shock Absorbers

The shock absorbers should be lubricated only after dismantling them (see page 47).

Windscreen Wiper

A drop of thin oil should be occasionally applied to the windscreen wiper mechanism—say, once a month. A small screw (except in the Trico model) is removable from the top of the casing allowing the oil to be injected.

Road Springs

The ends of the road springs where they are attached to the axles are provided with grease gun connections, and should be given a charge once a week if the car is continually used. After a long period of use it is advisable to lubricate the leaves of the spring with a warm mixture of white lead and tallow in equal parts. This can best be applied with a stiff brush, the leaves being eased apart by a screwdriver; first jack up the car, not under the axles, nor the radius rods, but under the frame to take the weight off the springs. The rear of the car can be jacked up one side at a time. The best point of the frame at which to apply the jack is each end of the rear cross-member. At the front, as there is only one transverse spring, the whole of the car must be lifted, and as a safety measure, the rear wheels should be "scotched" to prevent the car running off the jack. A short stiff bar is placed across the frame, just forward of the engine oil reservoir, and behind the spring, and the jack lifts the car from the centre of this bar. It will be necessary to block the jack up for this work, with a wood block, to avoid necessitating an excessive lift.

Front Hubs

Remove the road wheel (see page 11). Turn the hub until the plug "A" is at the top. Screw out the plug and screw in the adapter which is provided in the kit.

Fill the hub with grease. It is important that the hubs are not given too much grease, otherwise the brakes will not be effective. The handle of the grease-gun should not be turned

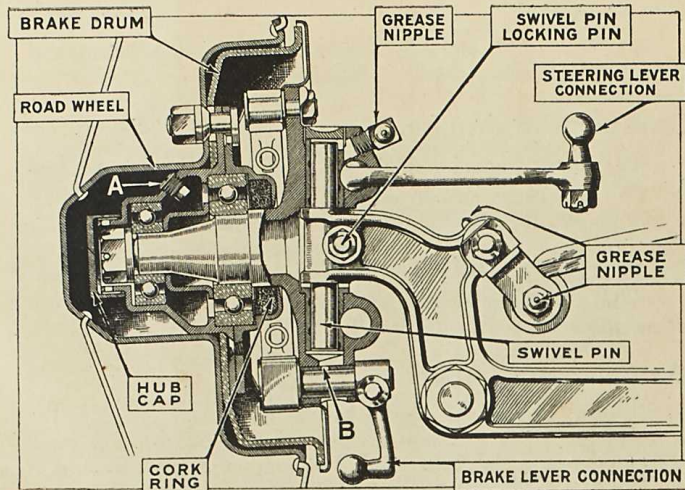

The front hub in section, showing the grease plug A.

down more than twice to give the maximum charge advisable.

Rear Hubs

Remove the road wheel. Turn the wheel until the plug at "A" is at the top. Inject grease into the hub; if the handle of the gun is given two turns the grease will be sufficient for ordinary maintenance purposes.

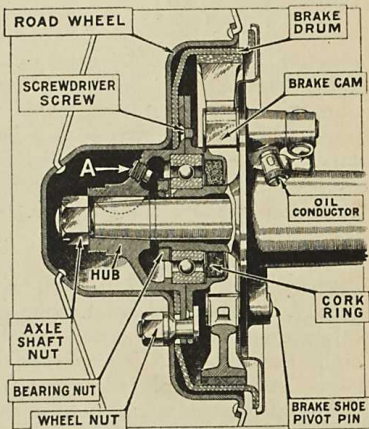

A section of the rear hub, showing the grease plug A.

Fan

The fan bearing requires a charge of grease once a month through the nipple on the fan bracket.

Other Points

Occasionally give a drop or so of oil to the engine control joints, the door locks, the hood frame hinges, and all other small working joints. This will keep them working smoothly, without wear, which would ultimately cause rattle.

ELECTRICAL EQUIPMENT

THE lighting and starting units on the "Austin Seven" car are arranged for wiring on the single wire system, the return path of the current being provided by the frame instead of a second wire. It is essential that all units are in metallic contact with the frame.

Should difficulties arise that cannot be understood or remedied from the information given below, application should at once be made to the Austin Service Department or the nearest service depot of the makers of the equipment (address on page 53).

Dynamo

The dynamo is a simple self-regulating third brush machine. The only parts calling for any attention are the commutator and brushes, which are readily accessible when the cover is removed. The commutator surface must be kept clean and free from any oil or brush dust. It may be cleaned with ordinary soft rag but if it has been neglected use fine glass paper. Blow away any carbon dust, see that the carbon brushes are wearing evenly and move freely in their holders. To fit a new brush it is only necessary to release the brush tag, hold back the brush trigger and then withdraw the worn brush from its holder. The new brush can then be fitted by reversing the above operations.

The dynamo bearings are packed with grease before leaving the works and need very little attention. A few drops of ordinary engine oil, however, may be added through the lubricators, say every 1,000 miles. The owner is cautioned that far more trouble is caused by excessive oiling than by too little.

Starting Motor

The commutator is accessible on removing the clip secured cover. The unit requires very little attention beyond keeping the commutator clean and free from oil, brush dust, etc., as in the case of the dynamo. Before starting from cold do not neglect the preliminary precautions that you would observe if starting by hand, such as flooding the carburetter, etc. Remember that although the starter will turn the engine over, however stiff, it is advisable to crank the engine over by hand two or three revolutions as this will considerably diminish the load for starting.

If the starter pinion jams in mesh with the flywheel ring when operating the starting motor switch, usually it can be released by putting the gear lever into top gear, and moving the car bodily backward and forward. If this plan is ineffectual the starter will have to be dismantled.

Never use the starting motor to propel the car, as it throws too severe a strain on the battery and the starting motor.

If the engine does not start at the first attempt, do not press the starter switch until the engine has come to rest. If this precaution is not adopted, the starter ring teeth on the flywheel cover, or the starter pinion teeth, may be damaged.

Switchbox

The switch box houses two switches controlling the lighting and charging circuits, and a centre-zero ammeter. The charging switch is also arranged so that in the "off" position it earths the magneto, thus obviating the necessity of a separate switch.

The switch box is provided with an adapter for the Lucas inspection lamp.

Switch Positions

Each switch has three positions. Left-hand switch (1) "off" position—charging circuit broken and the magneto earthed. (2) "M" position—magneto operating but dynamo still not charging. (3) "D" position—dynamo charging and magneto operating. Right-hand switch. (1) "Off" position—all lamps off. (2) "S" position—dim light of driving lamps and tail lamp. (3) "H" position—bright light of driving lamps and tail lamp.

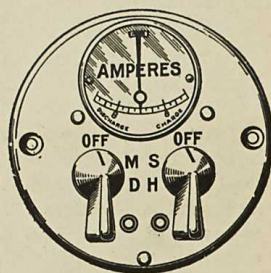

Ammeter Readings

When the car is running at about 25 m.p.h. with no lamps in use and the charging switch "on" the ammeter should give a charge reading of 6—8 amperes. A more exact figure cannot be given as there are a number of factors that cause the dynamo output to vary slightly, such as its temperature and the state of charge of the battery.

When the lamps are switched on with the car still running the metre shows the current in excess of the lamp load which is available for charging the battery.

If the engine is stopped the following readings on the discharge side of the scale will be given:—With dim light of driving lamps and tail lamp on—about 2 amps. With bright light of driving lamps and tail lamp on—about 7 amps.

Should no ammeter reading be indicated when the car is running at say 20 m.p.h. with the charging switch "on" and the lights "off" first inspect the fuse to see if it has blown and if necessary replace it. Then examine all connections on the dynamo, battery, cut-out and the terminals + D, A & + B on the switchbox to see that they are tight and unbroken.

If the maximum ammeter reading is much below normal when the dynamo is charging when the lamps are "off"; or if the needle fluctuates when the car is running steadily, a low or intermittent dynamo output can be suspected. The dynamo may have been neglected, and the trouble may be caused by say worn brushes, or a dirty commutator (refer to the dynamo recommendations).

Cut-out and Fuse

The cut-out and fuse are mounted on the same base, the larger cover "A" protecting the cut-out and the smaller one the terminals and fuse. The cut-out automatically closes the charging circuit as soon as the dynamo voltage rises sufficiently

above that of the battery. When the dynamo voltage falls below that of the battery, the reverse action takes place, the cut-out opens and thereby prevents the battery from discharging itself through the dynamo.

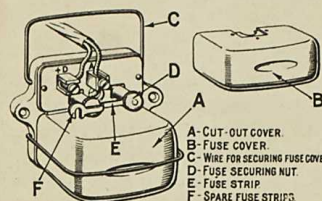

The cut-out is accurately set before leaving the works, and does not need any adjustment and is therefore sealed.

The cover "D" protecting the fuse holder and terminals is removed by springing up the retaining wire "C".

To fit a new fuse it is only necessary to remove the knurled nut "D" place one of the spare fuse strips "F" over the post, and then replace and tighten up the nut.

Should it be found that the fuse is continually blowing, do not use two or more strips to prevent this occurring, but have the equipment thoroughly examined to find out the cause of the trouble.

Battery

It is of the utmost importance that the battery receives regular attention, as upon its good condition depends the satisfactory running of the starting motor and the illumination of the lamps.

Regular Inspection

At least once a month the vent plugs in the top of the battery should be removed and the level of the

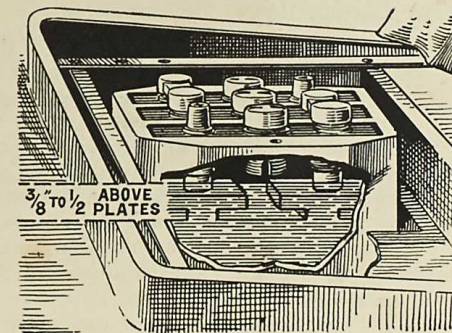

acid solution examined. If necessary distilled water, which can be obtained at all chemists and most garages, should be added to bring the level well above the plates. If, however, acid solution has been spilled it should be replaced by a diluted sulphuric acid solution of 1.275 specific gravity. It is important when examining the cells that naked lights should not be held near the vents on account of the possible danger of igniting the gas coming from the plates. It is advisable to complete the inspection by measuring the specific gravity of the acid, as this gives a very good indication of the state of charge of the battery. An instrument known as a hydrometer is employed for this purpose; this may be obtained at the Austin Service Department, or from the service depots of the makers of the equipment.

Charging Period

It is difficult to lay down rigid instructions on this subject, as the condition under which cars are used vary considerably, and obviously the amount of charging the battery will require is directly dependent on the number of starts made and the extent to which the lamps are used. The following suggestions will serve as a rough guide.

(1). Under normal conditions providing that the lamps and starter are used a fair amount, the battery should be kept on charge all the time during the winter, and half the daytime running in the summer.

(2). Always keep the battery charging switch "on" when the lamps are in use.

(3). If the car is used for long hours in the daytime, it is unnecessary to keep the charging switch "on" all the time, as this will cause excessive overcharging of the battery and the consequent reduction of the acid level.

Should the state of the battery be continually bad, see that all its connections through the starter switch to the switchboard are tight and unbroken, and that no wire has a chafed covering, allowing leakage of current to the frame.

The Electrolyte

When the battery arrives empty (as in the case of cars sent abroad) the first thing to do is to fill and charge it.

This means that a fluid is prepared composed of one part (by volume) of pure brimstone concentrated sulphuric acid with three parts (by volume) of distilled water. Mix these in a glazed earthenware vessel. Great care must be taken in this operation. Add the acid in very small quantities, almost drop by drop, and stir with a glass rod.

Never add the water to the acid. This is highly dangerous, and a serious explosion may result.

This mixing generates heat, and it is important that the electrolyte (as the mixture is called) should not be used in the

battery before it has been allowed to cool. Pour the electrolyte into the cells of the battery by means of a lead, glass or celluloid funnel, until it completely fills the cells to the top of the vent hole. Allow the battery to remain in this condition for 10 minutes or so, then put in more acid so that each cell is again filled to the same point with electrolyte. The electrolyte will have a specific gravity of 1.275 when fully charged. Batteries may be charged at almost any service station.

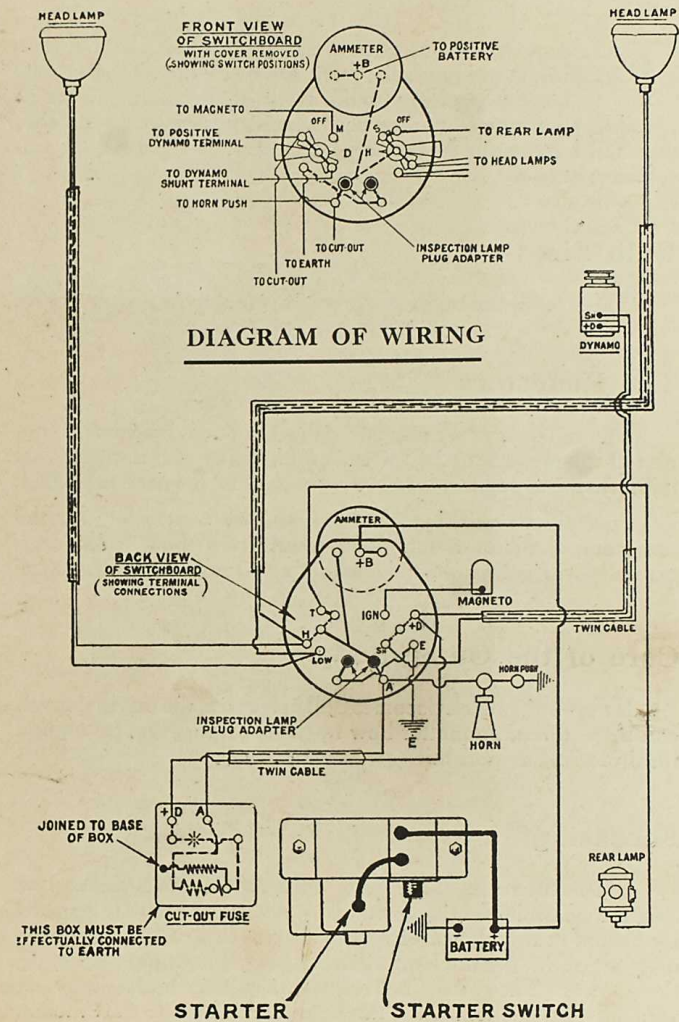

CARE OF THE LAMPS

Bulb Replacement

TO remove the front of the head or side lamps for a bulb replacement, press the front rim evenly, and then rotate to the left (looking at the front of the lamp) as far as possible, when the front may easily be withdrawn. In the case of a tail lamp bulb replacement the front is removed by unscrewing it to the left.

Bulb Sizes

The sizes of the bulbs are :—Head, No. DO18 ; Tail, No. 74.

The Reflectors

The reflector of a lamp is a delicate optical instrument, not part of the metal work of the car and is easily and destructively injured if metal polishes, brick-dust or paraffin are used to clean it.

Special soft cleaning cloths should be kept solely for the reflectors. Do not touch them unless tarnished, then clean carefully with a fine chamois leather and rouge wet with petrol.

Care of the Outer Body

If the ebony black becomes dull in service, the original finish can be restored, no matter how neglected it may be, by a good furniture or car polish.

Focussing

Unless the focus of the bulb in the reflector is correct, quite half the possible light may be lost. A correct focus is secured by means of the choice of several positions in which the bulb may be fixed. Set the lamps correctly level, pointing neither up nor down. They can be adjusted, either horizontally or vertically, by slackening the nut holding the lamp to the bracket.

RUNNING ADJUSTMENTS

THE adjustments set out below are all that the amateur owner will find necessary to make to keep the car in good running order.

Valve Tappet Adjustment

To ensure obtaining the full power of the engine, and to maintain silence in the valve operation, it is essential to keep the tappets correctly adjusted. To make this adjustment, first remove the valve cover, turn the engine slowly round with the hand starting crank. Watch each valve open in turn and note the point at which it stops descending. Now turn the engine half a revolution further to make sure that the cam is well away from the tappet. There should now be between the valve

stem A and tappet screw B a clearance equal to the thickness of the thin blade of the "tappet clearance gauge." If the clearance is other than this it can be adjusted by loosening the lock-nut C and raising or lowering screw B, being careful to tighten up

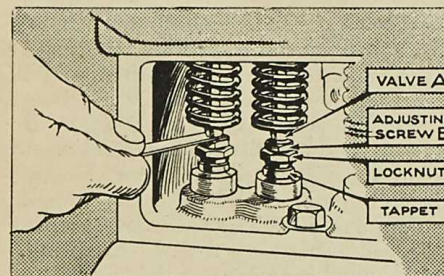

the lock-nut when the adjustment is completed. A special spanner is provided in the tool kit for this operation. Check this adjustment when the engine is warm.

Cleaning Combustion Chamber

To secure the maximum efficiency from the engine it is necessary to remove the carbon deposit that will have formed on the surfaces of the combustion chamber. This should be done after about 2,000 miles running. When the cylinder head is off it may be advisable to take this opportunity of grinding-in the valves, although this will need a longer time for the work to be carried out. In any case, it is recommended that after about 4,000 miles the work of grinding-in the valves should be undertaken.

First drain off the water through cock under the radiator. Detach the top water tube from the head. Disconnect the high tension wires from the sparking plugs. Remove the nuts holding down the head. Then take hold of the head at each

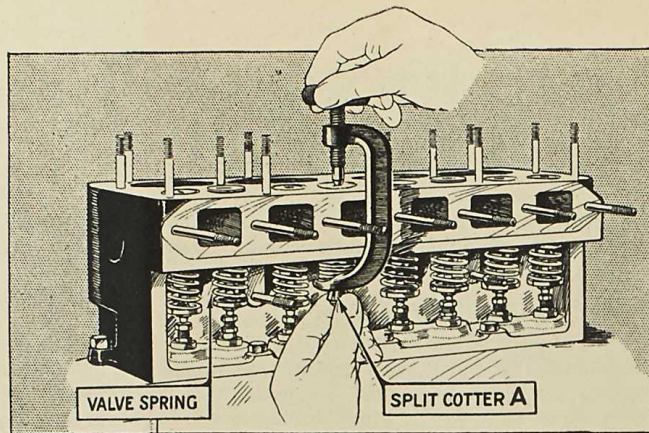

end and lift it off. This should be fairly easy to do, without damaging the joint washer, which should, in the ordinary course, be in a condition to be replaced.

Removing the Carbon

When the head has been removed the valves and tops of pistons will be exposed to view. All dirt or deposit should be removed by carefully scraping with a sharp tool. Before grinding-in the valves it will be necessary to remove the inlet pipe, and exhaust manifold, and carburetter, first turning off the petrol and uncoupling the pipe under the float chamber, then disconnecting the carburetter control, the air strangler wire, and the windscreen wiper tubing. The valve cover, with its cork washer, can be removed on undoing the two milled nuts. Each valve spring must be lifted by means of the special tool provided to allow the split cotter A to come out (see illustration); then remove the spring. The valve is now free to be rotated on its seat when the tappet screw has been lowered clear of the stem. After it is cleaned a little grinding compound should be smeared evenly on its face, and the valve rotated backwards and forwards, advancing it a step at short intervals until the pitting is removed. Care should be taken that none of the compound enters the cylinders and the valve and seating should be wiped clean after the operation. It is also desirable to clean the valve guides. This can be done by dipping the valve stem in petrol or paraffin and moving it up and down, and round, in the guide until the dirt is removed. Then the valve should be cleaned, and the stem smeared with graphite grease and re-inserted in the guide; the valve spring and cup being fitted up round it. The valve lifter is then used as before to compress the spring, so that the split cotter can be refitted. The smaller diameter of the complete cotter should be uppermost, and the cotter should be fitted down onto the collar at the bottom of the stem. The grease on the stem will help to hold it in position

while the lifter screw is slackened, to allow the valve cup to come down over the cotter. It is easiest if the end valves are fitted first, working towards the centre ones. When refitting the manifolds ensure that the joints are good. The cylinder head joint washer should be replaced, copper side downward, with a little graphite grease smeared over each side, to make a good joint and to prevent it sticking when the head has next to be lifted. Note that it is essential for each valve to be ground-in and refitted on its own seating, as indicated by the number on the valve head. The valves are numbered from 1 to 8, starting from the front. When replacing the head take care to tighten the nuts evenly. Don't forget, after replacing the head, to refill the radiator.

Lifting the Cylinder Block

For access to the pistons (except the piston crowns), and the connecting rods, or for fitting a new tappet plunger or guide, or valve guide, it is necessary to lift the cylinder block. The three nuts on the magneto side are easily removed, also the three barrel nuts on the valve side can be removed without difficulty. For access to the nut at the front of the cylinder block the dynamo and casing with the fan bracket and fan, must be lifted clear. The casing is secured by four set screws. The one under the dynamo itself is not very easy of access, also the one nearest the cylinder block requires the special small spanner supplied in the tool kit, which can be turned 30° , and then refitted to the nut. With the casing removed, the front cylinder block nut is accessible. For access to the rear nut of the block, it is advisable to lift the starter-motor and casing, from its mounting over the flywheel. This is done by removing the two set screws, and lifting the casing clear vertically off its positioning dowel. The cylinder block can be lifted when the lower hose connection has been removed. When refitting the starter-motor casing, the larger set screw is required at the nearside of the casing. There is no joint washer between this casing and the crankcase, but paper joint washers are used between the cylinder block and the crankcase, also under the dynamo casing. These joints must be oil-tight. When refitting the cylinder block it is necessary to use sleeves on the pistons to compress the rings. These piston ring sleeves are among the extra tools obtainable from the Service Department of the Austin Motor Co., Ltd.

Adjusting the Brakes

The hand brake operates on the front wheels and the foot brake on the rear wheels. They require adjusting when the hand lever can be pulled right back to the full travel on the rack, and when the pedal can be pushed nearly to the floor-board without either brake holding the wheels. The car should never be taken out when in this condition, but should be attended to at once.

Access to the handbrake mechanism is through the small cover in the centre of the car, just behind the gearbox.

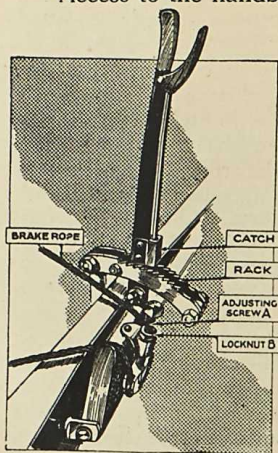

To adjust the hand brake pull the lever on about one-third (or to suit driver's reach) of the total travel provided by the rack. Now unlock the nut (B) and screw up the brake adjusting screw (A) until the shoes are hard on the drum. If the brake shoes do not then rub on the drum, when the lever is right forward, the adjustment is correct. See that the screw is locked again by nut (B).

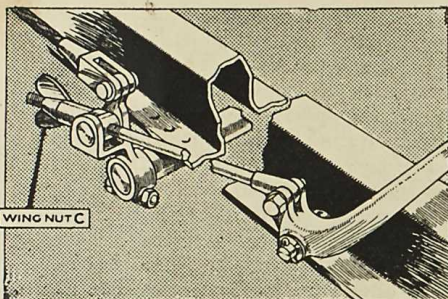

To adjust the foot brake: Under the car and approximately under the foot controls is a wing nut (C). This must be screwed towards the front of the engine until the brakes go full on when the pedal is depressed about 2 in. When the pedal is up, the brake shoes should not rub the rear wheel drums in which they operate.

Rear Brake Compensation

For compensating the rear brakes, which may be necessary after re-lining the shoes, an individual adjustment for each of the rear brake cables is provided. A screwed end, to which the cable is attached, screws into the front fork-end, which secures the cable to the compensating tube lever. By removing the fork-end from the lever (a pin, secured by a split-pin, holds it) the fork can be screwed further on or off the screwed cable end to effect the compensation. The cable must not be twisted while this is being done. To test whether both brakes engage equally at the same time, jack-up the back axle, and with the brake pedal pressed down, turn each wheel by hand to judge the braking effect.

Tracking Adjustment

One of the causes of premature tyre wear is the front wheels being out of track. The wheels, if they are correctly tracking should not be parallel, but should be $\frac{1}{8}$ in. closer between the

rims in front of the axle than they are behind. This difference, or "toe-in" as it is called, allows for working clearances of the steering connections, and any slight spring of the parts, so that when the car is running the wheels are as near parallel as possible. If on checking this difference, it is greater or smaller than $\frac{1}{8}$ in. the tracking should be adjusted. This is not difficult to effect. It is necessary to remove the cross tube lever, on the near side, from the swivel axle. It is secured by a nut on the front of the swivel axle, under which there is a spring washer. With this done, the steering cross tube is freed at the near side for the adjustment. On the clamping bolt of the steering arm jaw being slackened, the jaw can be screwed further on, or off, the cross tube, for so many complete turns, as may be necessary. This movement will enable the correct adjustment to be attained; when the clamping bolt is re-tightened. On refitting the cross tube lever to the axle, do not forget to fit it with the key, and tighten the nut securely, with the spring washer under it. This, as well as the steering adjustment described below, is one of the adjustments which it is advisable to leave to the Austin agent to effect; who is properly equipped for the work.

Adjustment of Steering

If after continual use slackness should be felt in the steering, two adjustments are available:—To take up the play in the column, loosen the nut which tightens the bracket supporting the steering outer column to the instrument board, unscrew locking peg (A) and clamping bolt (B), then turn the sleeve (C) with the special spanner provided for the purpose, until the play has been removed. Do not screw the sleeve in too tight

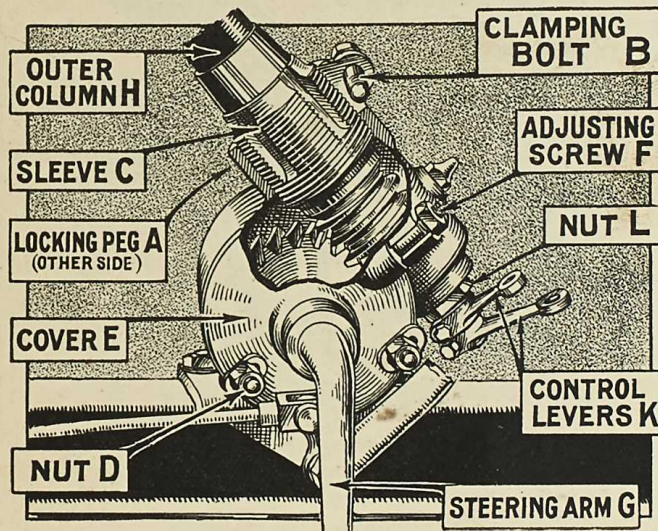

or the steering will then become stiff. Having adjusted the sleeve correctly, screw in the locking peg so that it enters one of the slots of the sleeve, tighten up the clamping bolt, and the supporting bracket to the instrument board.

To take up the clearance between the worm and worm wheel, due to wear, remove the locking plates and slacken the three nuts (D) holding the cover (E) to the worm casing, then turn adjusting nut (F) so as to slightly draw the cover in the direction of the worm. Care must be taken that the worm wheel is not brought too tight into mesh with the worm or it will make the steering exceedingly hard and stiff. Having made the adjustment be sure and tighten up the three nuts (D) and lock them with the locking plates.

Should it be desirable to remove the steering worm wheel from the casing, it is only necessary to slacken the adjusting nut (F) and remove the three nuts (D) when the cover (E) can be withdrawn together with the worm wheel and steering arm. The steering column (H) with control rods can be withdrawn by first removing control levers (K), and nut (L), then slackening locking peg (A), and clamping bolt (B), and unscrewing the sleeve (C). These adjustments, again, should be left to an Austin agent to effect.

Re-lining the Brakes

To re-line the brakes it is necessary first to remove the wheel, and then the brake drum, by unscrewing the three screwdriver screws which secure it to the hub ; and, before the

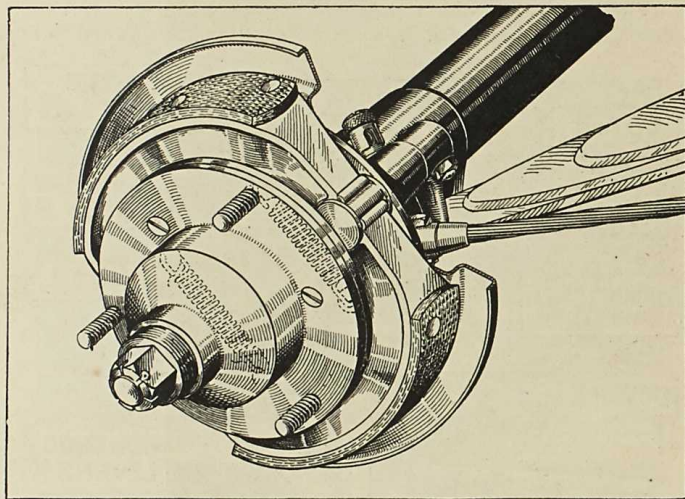

shoes can be removed for re-lining, the hub and wheel bearing must be extracted. For this a special hub extractor is supplied in the tool kit.

Rear Brakes

For the rear wheel brakes (see illustration on page 32) remove the axle shaft nut, having first taken out the split pin, and extract the outer portion of the hub by screwing the extractor on the screwed end, and turning the extractor bolt which bears on the end of the axle shaft. Remove the key from its keyway in the axle shaft. Next remove the bearing nut, having knocked back the tang of the washer locking it, and prise the inner portion of the hub or felt housing together with felt packing and bearing, off the end of the axle casing. Do not damage the paper washer between the hub and the felt housing faces, as it is important to make a good joint on reassembling, to prevent the hub lubricant penetrating to the brake. If this inner portion of the hub does not easily come off the axle casing, the outer half should be refitted as closely as possible, using the wheel nuts to draw the two halves together. Then use the hub extractor a second time, and so remove the hub together with bearing and packing. The brake shoes can now be pulled off the cam and pivot pin and the springs unhooked. The old linings can then be detached by punching or drilling out the rivets.

The brake linings should be clamped to the shoes while the riveting is in progress, as it is essential that they should bed down on the shoes over their whole area.

Reassembling

To reassemble, replace the shoes with their springs on the cam and pivot pin. Replace the inner portion of the hub or felt housing with the bearing and packing on the axle casing end, and push up home by tightening the bearing nut, which must be locked by the locking washer in the same way as before dismantling. Replace the paper joint washer on the felt housing face, insert the key in the shaft, push the hub over the axle shaft, on the key, and draw it up to the felt housing by the wheel nuts on their studs. When the joint faces of the hub and the felt housing are together replace the axle nut and tighten securely up to the hub boss. *Remember to insert the split pin through the nut.* Then remove the wheel nuts from the hub, fit the brake drum, and insert and tighten the three screwdriver screws.

Front Brakes

For the front brakes (see illustration on page 32) the operation is somewhat similar. Having removed the wheel, and the brake drum, secured by the three screws, remove the hub cap, and screw on the extractor in its place. Before proceeding further, remove the plug (A) from the hub, or unscrew it for about three turns ; otherwise it will foul the outer hub bearing when the hub is being extracted. Draw off the outer portion of the hub. The axle nut and split pin will now be accessible for

removal. Now replace the outer portion of the hub and pull it up to its original position by the wheel nuts, as in the case of the rear wheel. By means of the extractor draw off the hub with its bearing and packing. The brake shoes are left clear for removal. On reassembling remember to fit a new split pin through the axle and nut; there is a hole in the end of the hub through which the pin can be inserted.

It is always necessary to re-line all four brake shoes on the one axle at the same time, and after the re-lining it may be necessary to slack off the brake adjustment before the brake drum can be replaced.

After re-lining the brakes make sure that the hubs contain sufficient lubricant, re-adjust the brakes and compensate them, if necessary (see pages 41 and 42).

Adjusting Austin Front Shock Absorbers

The shock absorber is set to a certain initial tension before it leaves the factory, and no change in this adjustment should be necessary for a very considerable time.

Re-adjustment may only become necessary after several thousand miles of car travel, and should be made only when the spring movement seems too free. It should be noted that, normally, the full benefit of the shock absorbers will not be felt when the car is travelling at low speeds, as under these conditions the spring movement is very limited, but, as the speed increases their effect becomes more pronounced, especially over bad roads when the spring action is most severe. Testing should, therefore, be carried out at comparatively high average touring speeds and adjustment made to suit these conditions.

The frictional resistance required to effectively control the action of the springs is comparatively small, and care should be taken not to alter the pressure, when adjusting, more than is absolutely necessary in order to obtain the desired results.

For fast sporting cars and for road and track racing, a considerable increase in pressure may, of course, be required.

When adjustment does become necessary, carefully note the riding qualities of the car, and if the spring action seems too retarded or stiff, reduce the frictional resistance of the shock absorbers by turning the centre adjusting nut to the left, or counter-clockwise, after slackening the lock nut. If the spring action seems too free, increase the frictional resistance by turning the adjusting nut to the right, or clockwise. After adjusting, tighten the lock-nut.

Careful adjustment in this manner will produce an ideal condition. The spring will still have the required amount of flexibility for easy riding, but spring vibration will be reduced to a minimum and violent rebound effectively eliminated.

The rear Austin shock absorbers do not require adjustment.

Cleaning the Shock Absorbers

Periodically—especially in wet weather when much mud is thrown on to them—the large end of the shock absorbers should be taken apart, by withdrawing the centre bolt, and thoroughly cleansed. The centre pin and washers should be well lubricated, and a thin smear of grease, used with discretion on the friction surfaces will prevent the entry of moisture, and so prevent the shock absorbers becoming tight and inoperative.

If this precaution is not adopted, the shock absorbers are liable to become tight—when an excessive load is thrown on the pins and bushes at the end of the arms, which will cause rapid wear. In addition, great strain is imposed on the bracket holding the shock absorber to the frame.

Clutch Slip

Some drivers are inclined to use the clutch instead of changing down to a lower gear, particularly when they are almost at the top of a hill and it is only necessary to change down for a few yards. Foot pressure is applied to the clutch to create a certain amount of slip (see page 10). This highly polishes the frictional surfaces and will eventually be the cause of persistent slip; finally in addition to burning out the fabric rings, probably also distorting the centre plate and making renewal of this essential.

Sometimes clutch slip is due to oil penetrating to the clutch from the engine or gearbox. This results from over-oiling of either or both of these units (pages 28 and 29). If the inspection plate over the clutch casing is removed petrol can be syringed on the clutch plate to wash off the oil, so that the clutch regains its frictional characteristics. The petrol and oil will drain away through a hole in the casing under the flywheel.

When injecting the petrol have the engine turned so that the plate is properly washed and the petrol and oil are given an opportunity to drain away, also push the clutch out and let it in by the pedal so that the petrol is given a washing action. Do not replace the inspection plate, until the oil and petrol have had sufficient time to evaporate off.

After this operation it is advisable to lubricate the clutch withdrawal collar (page 29) as the lubricant in this member may have been removed by the petrol.

There is no adjustment necessary for the clutch.

Fan Adjustment

Release the clamping pin nut on the fan bracket and then turn the spindle, which is in the form of a crank, until the necessary tension is obtained in the fan belt.

CARE OF THE HOOD

Lowering the Hood

To lower the hood, first release it from the pillars of the windscreen, push the side screens inwards so that the rubber buffers fixed near the top of the division on the side screens clear the iron framework of the hood.

Now push the hood straight up and back from the front and break the joint of the iron framework, see illustration.

The picture shows very clearly the commencement of the "concertina" movement which begins the actual lowering of the hood.

The hood will then collapse towards the back of the car. Pull the folds out until they lie in one big fold over the back of the car; see below.

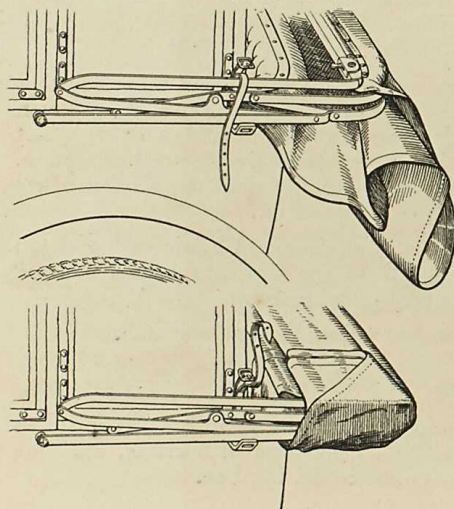

Now fold them back carefully, seeing that the edges are evenly placed, turn them in, either side—see illustration below—or under and put the cover in position over all.

The cover is secured by a strap which is brought up *inside* the iron framework, passes through the slot (A) in the cover, thence *downward*—see illustration on next page—

through the eye (B) in the iron bracket pulled tight and buckled at (C).

Raising the Hood

To raise the hood, remove the cover and unfold the hood material. Lift the top hood stick vertically holding the metal sidestrip of the hood frame near the hinge. If the front hood stick is then pushed forward and the metal strips are pulled back, to straighten the hinge, the whole hood can be dropped forward and secured in position to the windscreen.

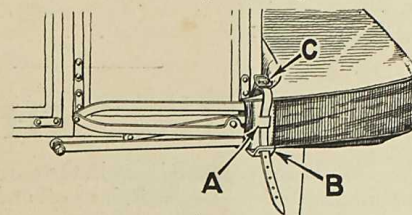

Care of the Hood

Care should be taken in folding down the hood to see that the original folds are used. Should the car have been used in wet weather leave the hood up to dry. Never fold it when wet.

The joints will be stiff when new; they are intentionally made so, in order that they will not rattle when they have worked in. Each joint and hinge should have a drop of oil occasionally; this will ease the movement. The best dressing for the "Austin Seven" hood is good quality black boot polish. Brush it in, particularly round the seams, and rub it well so that the polish is forced into the grain of the material to keep it waterproof.

CARE OF THE BODYWORK

FOR the car to look well and keep its beauty and smart appearance, the body must be given its share of attention; it must not be neglected.

Washing

The cellulose finish of the car is easily cleaned and polished. In summer weather when the car is only dusty the dust can be removed without water and there is no risk of damaging the finish. When the car is muddy, wash off well with clean running water. Remove any grease or tar splashes with petrol. Don't use the same sponge and cleaning cloths for the chassis and springs and other greasy parts as are used for the coachwork.

Polishing

Dry off and then polish with one of the special polishes now marketed. Such preparations impart a brilliant surface and preserve and beautify the body. On no account should metal polishes be used, as are sometimes advertised for cellulose. It has been found that the more the surface of the cellulose finish is rubbed by the polishing cloth, the smoother and more lasting is the lustre imparted.

STORING THE CAR

Should the car be laid up in the garage for long periods, the fuel and water should be drained off and the batteries removed, and weight taken off the tyres.

THE TYRES

Tyre Pressure

The correct pressure at which both front and back tyres should be inflated is 20 lbs.

As tyres form such a large item in the running costs of a car it is advisable to give them periodical examination and attention.

A cursory glance should be given daily to see that none of the tyres is unduly slack, and a weekly test with a suitable gauge should be made to verify the pressures. Occasionally examine the tyre treads for cuts; bad cuts should be vulcanized.

Tyre Wear

Because of the turning in of the wheels towards each other at their lowest point, it has been found that the front side tyre wears at its outer edge. The camber of the road tilts the car towards the left, and the tyres are distorted. It is in the action of recovering their correct shape, immediately after contact with the road, that they suffer abrasion, made more damaging because the gritty substances now used on tarmac road accumulate on the near side and the wheel is running in this grit for most of the time it is on the road. So change your front wheels over and thus equalize the wear between the tyres. When both tyres have become worn on the outside edge, change over the back wheels with the front wheels. Subsequently the tyres can be turned round, bringing the least worn edge to the outside. If the front tyres should show premature wear at any time suspect the tracking of the front wheels. Have it checked, to see if it is correct, and, if necessary, adjusted (see page 42).

TOOLS SUPPLIED WITH THE CAR

$\frac{1}{4}$ in. and $\frac{3}{16}$ in. box spanner.	Tool wrap.
$\frac{3}{8}$ in. and $\frac{1}{2}$ in. box spanner.	Sparking-plug box spanner and tommy bar.
$\frac{3}{16}$ in. and $\frac{1}{4}$ in. double open-end spanner.	Brace for detachable wheels.
$\frac{5}{16}$ in. and $\frac{3}{8}$ in. double open-end spanner.	Tyre levers.
$\frac{7}{16}$ in. and $\frac{1}{2}$ in. double open-end spanner.	Tyre pump.
Adjustable spanner, 4 in.	Lifting jack, with handle.
Carburettor jet key.	Screwdriver.
Hub-cap and steering column sleeve spanner.	Sparking plug and tappet clearance gauge.
Magneto spanner.	Grease gun with adapter.
Tappet adjusting spanner.	Valve-spring lifter.
Spanner for dynamo casing and monobloc nuts.	Trade-mark cleaning plate.
	Combination pliers.
	Hub extractor.

A spare cylinder-head joint washer is also supplied.

READ "THE AUSTIN MAGAZINE AND ADVOCATE" A MONTHLY JOURNAL OF ROAD TRAVEL

Each number contains useful information on the adjustment and maintenance of Austin Cars

Obtainable at all bookstalls, Price 4d.,
or 5/- per annum, post free.



EQUIPMENT APPLICABLE TO ALL MODELS

The Austin Motor Co. Ltd., accept no liability under the terms of their Warranty for Tyres, Speedometers, or the Electrical Equipment, or other goods, including Coachwork, not of their own manufacture.

All claims relating to any of these parts or fittings or orders for repairs to them, should be addressed to their manufacturers.

For our clients' convenience we give below the names and addresses of the manufacturers, or suppliers of the goods in question.

IMPORTANT

When claims under guarantee are being made it is absolutely necessary to quote the type and number of car and also the commissioning date.

Magnetos

- "B.L.I.C." Joseph Lucas, Ltd., Gt. Hampton Street, Birmingham, and Dordrecht Road, Acton Vale, London, W.3.
- "B.T.H." British Thomson-Houston Co., Ltd., Alma Street, Coventry.
- "M.L." M.L. Magneto Syndicate, Ltd., Victoria Works, Coventry.
- "Lucas" Joseph Lucas, Ltd., Gt. Hampton Street, Birmingham, and Dordrecht Road, Acton Vale, London, W.3.
- "Watford" North & Sons, Whippendell Road, Watford.
- "S.E.V." *Service by* Ripaults, Ltd., 1, Kings Road, St. Pancras, London, N.W.1.
- "Scintilla" Scintilla, Ltd., 14, Clerkenwell Close, London, E.C.1.

Horns

- "Lucas" (King of the Road) Joseph Lucas, Ltd., Gt. Hampton Street, Birmingham, and Dordrecht Road, Acton Vale, London, W.3.
- "Sparton" Graham & Co., St. Andrew's Works, Crofton Park, London, S.E.4.
- "A.R." A. Rist, Ltd., Waveney Works, Lowestoft.
- "Klaxon" Klaxon, Ltd., Landor Street, Birmingham, and 36, Blandford Street, London, W.1.
- & "Klaxet" }
- "Benjamin" Benjamin Electric, Ltd., Brantwood Works, Tariff Road, Tottenham, London, N.17.

- "Sygnol" Clear Hooters, Ltd., 79, Lombard Street, Birmingham.
- "Desmo" Desmo Limited, Desmo House, 31, Stafford Street, Birmingham.

Windscreen Wipers

- "Lucas" (King of the Road) Joseph Lucas, Ltd., Gt. Hampton Street, Birmingham.
- "Folbeth" C. G. Vokes & Co., Ltd., 95, Lower Richmond Road, Putney, London, S.W.15.
- "Trico" A. Rist, Ltd., Waveney Works, Lowestoft.

Electrical Equipment

- "Lucas," "C.A.V." and "Remy." Joseph Lucas, Ltd., Gt. Hampton Street, Birmingham, and Dordrecht Road, Acton Vale, London, W.3.
- Dynamos, Starters and Switchboards.* C. A. Vandervell & Co., Ltd., *Service by* Joseph Lucas, Ltd., Dordrecht Road, Acton Vale, W.3.
- Delco-Remy & Hyatt, Ltd., 111, Grosvenor Road, London, S.W.1.

Lamps

- "Lucas" Joseph Lucas, Ltd., Gt. Hampton Street, Birmingham, and Dordrecht Road, Acton Vale, London, W.3.
- "C.A.V." Joseph Lucas, Ltd., Gt. Hampton Street, Birmingham, and Dordrecht Road, Acton Vale, London, W.3.

Batteries

- "Lucas" and "C.A.V." } Joseph Lucas, Ltd., Gt. Hampton Street, Birmingham, and Dordrecht Road, Acton Vale, London, W.3.
- "Exide" } Chloride Electrical Storage Co., Ltd., Lexden Road, Acton, London.
- "Sparta" Fuller Accumulator Co. (1926), Ltd., Grove Road, Chadwell Heath, Essex.

Grease Guns & Oil Injectors

- "Enots" Benton & Stone, Ltd., Bracebridge Street, Birmingham.
- "Jeavons" Ramsdens (Halifax) Ltd., Station Works, Halifax.

Speedometers and Fittings, Clocks and Petrol Gauges

- S. Smith & Sons, (M.A.) Ltd., Cricklewood Works, London, N.W.2.

Bodies & Fittings

- "Mulliner" Mulliners, Ltd., Bordesley Green Road,
Birmingham.
"Gordon" Gordon & Co., Taunton Road, Spark-
brook, Birmingham.
"Hoyal" Hoyal Body Corporation, Ltd., 41, Charing
Cross Road, London, W.C.2.
"Gordon
England" Gordon England, Ltd., Palace of Industry,
Wembley.
"Startin" Thomas Startin, Junr., 71, Aston North
Road, Birmingham.

Driving Mirrors

- "Lucas"
(King of the Road) Joseph Lucas, Ltd., Gt. Hampton Street,
Birmingham.
"Desmo" Desmo, Ltd., Desmo House, 31, Stafford
Street, Birmingham.

Tyres & Tubes

- "Dunlop" Dunlop Rubber Co., Ltd., Fort Dunlop,
Erdington, Birmingham.

"Autovac"

Autovac Manufacturing Co., Ltd., Autovac
Works, Heaton Norris, Stockport.

Carburettors

- "Zenith" Zenith Carburetter Co., Ltd., 40-42, New-
man Street, London, W.1.

Radiator Thermometers

- "Boyce
Motometer" } Benjamin Electric, Ltd., Brantwood Works,
Tariff Road, Tottenham, London,
N.17.
"Calormeter" Wilmot Manufacturing Co., Ltd., Camden
Street, Birmingham.

Lifting Jacks

- "Midas" Lake & Elliot, Ltd., Albion Works, Brain-
tree, Essex.
"Shelley" R. T. Shelley, Ltd., Aston Brook Street,
Birmingham.

Owner's Name

Address

Car No.

Registration No.

Driving Licence No.

Insurance Policy No.

Memoranda.

A. J. W
LONDON

