

HANDBOOK

OF

*The Austin
Seven*



PUBLICATION No. 1400.

PRICE - ONE SHILLING.

— THE —
AUSTIN MOTOR CO. LTD.
LONGBRIDGE :: BIRMINGHAM

HANDBOOK

OF

*The Austin
Seven*

PRICE - ONE SHILLING

THE AUSTIN MOTOR CO. LTD.
LONGBRIDGE - BIRMINGHAM

G.P.O. BOX 41.

Telephones : - - - - - PRIORY 2101 (20 lines).

Telegrams : - - - - - "SPEEDILY, NORTHFIELD."

Cables : " SPEEDILY, BIRMINGHAM, ENGLAND." Code : BENTLEY'S

LONDON SHOWROOMS :

479-483, Oxford Street, W.1.

Telephone :

Telegrams :

MAYFAIR 7620 (18 lines)

" AUSTINETTE, TELEX, LONDON."

AND

HOLLAND PARK HALL

HOLLAND PARK AVENUE, W.11

Telephone : PARK 8001.

Repair and Service Depot for 7 h.p. :

25, NORTH ROW, LONDON, W.1.

Telephone : MAYFAIR 6271.

In reference to this Book
please quote the number. 1400

A FOREWORD

THE information contained in this Handbook is intended only to guide and assist owners or drivers of Austin cars to preserve the car in its proper satisfactory running condition. The publication must not be considered as a complete manual.

The handbook does not in any manner vary or extend the liability of the Company, which is limited to the Warranty issued with the car. Where no information is given for a particular adjustment it may be regarded as one which the average owner would entrust to a garage. When the occasion for adjustments of this character arises the owner should seek the aid of the local Austin dealer.

Both owner and dealer are encouraged to call upon the Service Department of the Company for advice, whether upon the management of the car, the effecting of adjustment, or methods of repair. Owners need not suppose that they will have to apply all the attentions given in this book, but careful notice should be taken of the chapters dealing with maintenance.

CAUTION.

Parts of genuine Austin manufacture only should be used when a replacement is made, to ensure that the service given by the original high quality of the car parts shall be maintained by the replacement. Imitations cannot be relied upon to do this.

If imitations are used, the Company's guarantee is infringed and becomes null and void.

Always get your replacements from authorised Austin Dealers, as they stock only genuine Austin Spare Parts.

Should repairs be executed by other than by an authorised Austin Dealer, for safety's sake always obtain a guarantee that genuine Austin Spare Parts are used.

CONTENTS

	PAGE
AMMETER READINGS	46
ATTENTIONS, Daily, Weekly, Monthly, Occasionally ..	12-13
BATTERY, The	47
BODYWORK, Care of	65
BRAKES, Adjusting, Relining, etc.	57-61
BRAKE GEAR, Lubrication of	40
CARBURETTER, Adjustment, etc.	19
"Sports"	23
CHASSIS LUBRICATION CHART	37
CLUTCH, Lubrication of Mechanism	39
COMBUSTION CHAMBER, Cleaning	54
CONTROL OF THE CAR	11
COOLING SYSTEM	27
DYNAMO, The	44
ELECTRICAL EQUIPMENT, The	44
ENGINE, Lubrication of	35
Starting the	8
FAN	28, 64
FUEL SYSTEM	17
FUSE, Action of the	46-53
GEARBOX, Lubrication of	39
GREASE GUN, How to use the	43
HOOD (Care of)	68
HUBS (Front and Rear) Lubrication of	41, 42
IGNITION, Timing	32
System, The	29
INFLATING SEAT INTERIORS	67
LAMPS, Care of	52
LUBRICANTS, Choice of	36
LUBRICATION CHART	37
PETROL PUMP	17
REAR AXLE, Lubrication of	40
ROAD SPRINGS	41
RUNNING ADJUSTMENTS	54
SHOCK ABSORBERS	63
SPORTS MODEL	23
STEERING, Adjustment of	61
STEERING GEAR, Lubrication of	40
THE NEW CAR	8
TOOLS, Supplied	69
TYRES, The	15
VALVE TAPPETS, Adjustment of	54
WHEEL, Changing a	14
WIRING, Diagram	51

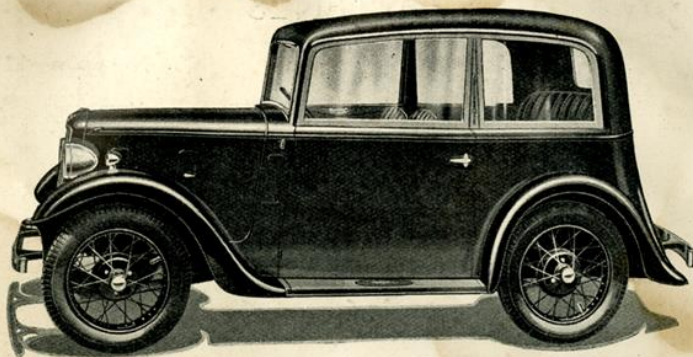

The Austin Seven de luxe Saloon.

THE AUSTIN SEVEN

THE Austin Seven is acknowledged to be the best small car in the world.

It is designed for, and will carry in comfort, four adults up to a weight of 40 stones and 56 lbs. of luggage.

There are six models made, the Cabriolet, the de luxe Saloon, the Saloon with fixed head, the Tourer, the Two-Seater and a Sports Two-Seater. The closed models are alike in general lines and general equipment. Particularly good features are the wide doors with one-piece windows, which are mechanically raised or lowered.

The large single panel windscreen, that can be opened wide and secured by an ingenious lever fastening easily reached from the driver's seat, is another advantage. The Tourer, with its easily operated hood, and side curtains that open with the doors, provides complete protection in even the most inclement weather.

Both front seats are separately adjustable. They tilt forward and allow ready access to the rear seats or luggage space.

The Sports model is a low compact fast car. The name accurately describes the "Two-seater."

The Austin Seven has a 4-cylinder, water-cooled engine, synchromesh gears, and bevel drive. Lubrication is by pump, and cooling is on the thermo-siphon system assisted by fan.

The complete equipment includes electric starting and lighting switches, foot operated "dip and switch" for headlamps, air strangler, electric horn, speedometer (both needle type and roller type are fitted as alternative), electric windscreen wiper, direction indicators,

license holder, shock absorbers, spare wheel and tyre and blank number plates. All fittings are chromium plated, except the wheel centres, which are of stainless steel.

The hand lever and pedal each apply brakes to all four wheels.

The Austin Seven is particularly suitable for the woman driver. It requires little physical effort to drive and control, and for that reason its use enables her to do shopping calls without fatigue, visit her friends, attend social and other functions, or make excursions or trips in any direction in any weather.

For the same reasons business men find it an excellent vehicle, and commercial travellers and others whose occupation compels frequent calls over an extended area have in the little car an embodiment of all they require. Calls can be made in places where trains, trams and buses are infrequent.

In large establishments, where the instant use of a car is of vital importance in cases of emergency, such as sudden illness or accident, the Seven has been installed as a "tender," and in addition to its superiority over large unwieldy cars for short runs, has proved a real time and money saver.

As 40 miles per gallon is the average petrol consumption, the cost of transit is below the cost of fares on any public conveyance, and in this particular the Austin Seven has no rival.

Its speed, economy, reliability and road-holding qualities have been admitted beyond dispute.

Thousands of motorists have had their first experiences on a "Seven," thousands more will follow them.

Having successfully passed through thirteen years of severe use and trial, it has emerged a really successful and popular favourite and its splendid qualities are internationally recognized.

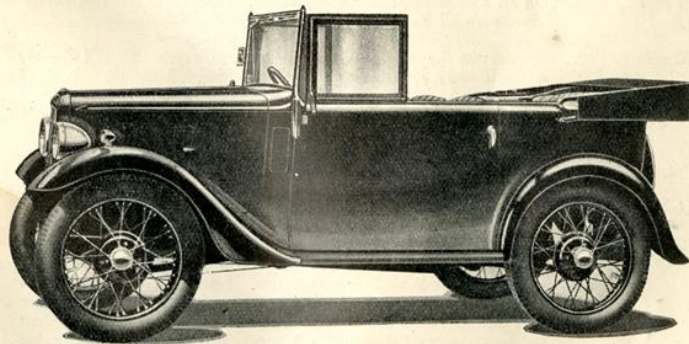

The Austin Seven Tourer.

CHASSIS SPECIFICATIONS

- Dimensions** .. The dimensions of the models vary. Maximum length 10ft. 7in. (3,26 mm.); Width 4ft. 4in. (1,320 mm.); Height 5ft. 3in. (1,600 mm.); Wheelbase, 6ft. 9in. (2,057 mm.); Track, front, 3ft. 4in. (1,016 mm.), rear, 3ft. 7in. (1,092 mm.). Ground clearance, 6½in., 6¾in. and 7½in., according to tyres. Sports Model, 4½in.
- Engine** .. Four-cylinder, water-cooled, detachable head.
Bore, 2.2in. (56 mm.) 747.5 c.c., R.A.C. rating, 7.8 h.p.
Stroke, 3in. (76 mm.)
Brake horse-power: 13.7 at 3400 r.p.m.
Ignition: Coil.
Oil circulation: by pump.
Cooling: Thermo-syphon with film radiator and fan.
Crankshaft bearings: Front, ball; Rear, roller.
- Starter** .. Electrical.
- Clutch** .. Single-plate.
- Gearbox** .. Four speeds forward, and a reverse; The top, third and second gears have synchromesh engagement, which ensures smooth, noiseless, certain gear changes to suit varying speeds. First gear is a low one to be used in starting with a full load, up an incline, or manoeuvring the car in an awkward place. The ratios of engine to road wheels are: top, 5.25 to 1; third, 8.73 to 1; second, 13.85 to 1, and first, 22.94 to 1. Ball bearings throughout.
- Rear Axle** .. ¾-floating, with differential and torque tube.
Ball bearings and thrusts throughout. Final drive by shaft and spiral bevel.
- Springs** .. ½-elliptic cross spring in front.
Quarter elliptics at rear.
Shock absorbers are fitted to front and rear.
- Steering** .. Worm and wheel, having provision for taking up wear.
- Front Axle** .. Forged, I section.
- Brakes** .. On all four wheels: easily adjustable. Both hand and foot brakes operate on all four wheels.
- Wheels** .. Special wire detachable. One spare wheel with tyre. Tyres 4.00—17, 4.00—18 and 4.75—16, Dunlop. Sports Model, 3.50—19.
- Controls** .. Ball change speed gear lever, and brake lever, mounted centrally. Foot control for dip and switch headlights. Foot accelerator.
- Petrol Tank** .. 5 gallon tank at rear. Fuel supply by petrol pump.
- Lighting** .. By gear-driven dynamo, with accumulators.
- Bodywork** .. Two bucket seats for driver and passenger, both being hinged to allow easy entrance to the rear seat. Rear seat to carry two adults or three children. Ample tool accommodation. Spare wheel and tyre. On touring model, hood, single piece screen and full side screens (those over the doors open with them). Electric horn, speedometer, direction indicators, automatic windscreen wiper, driving mirror and license holder.
- Workmanship and Materials.** Austin quality.

AUSTIN SEVEN CONTROLS.

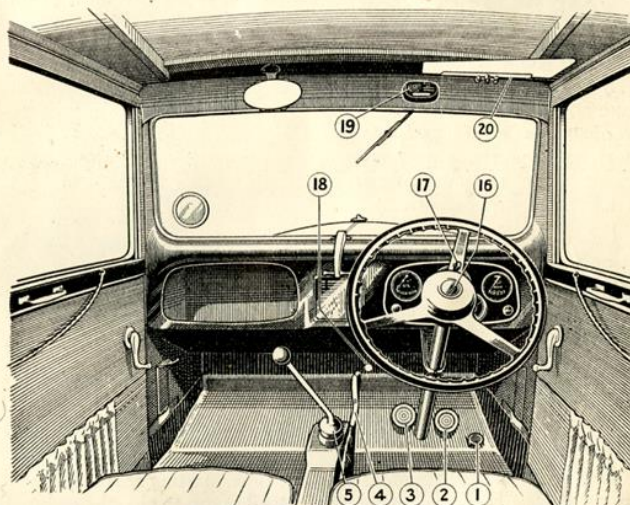

Austin
Seven
Controls.

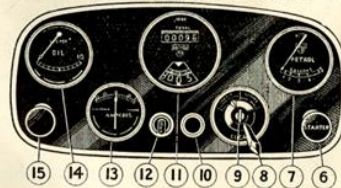

The
Instrument
Board.

- | | | |
|-----------------------------|-------------------------|-------------------------------------|
| 1. Accelerator Pedal. | 8. Switchboard. | 15. Strangler and Throttle Control. |
| 2. Brake Pedal. | 9. Ignition Key. | 16. Horn Button. |
| 3. Clutch Pedal. | 10. Warning Light. | 17. Direction Indicator Switch. |
| 4. Handbrake Lever. | 11. Speedometer. | 18. Dip and Switch Control. |
| 5. Change Speed Lever. | 12. Dash Lamp Switch. | 19. Windscreen Wiper Switch. |
| 6. Pull Out Starter Switch. | 13. Ammeter. | 20. Visor. |
| 7. Petrol Gauge. | 14. Oil Pressure Gauge. | |

THE NEW CAR.

It will Repay You to Read this Carefully.

IF you are not familiar with Austin cars please read this Handbook carefully.

Give the new car a general examination to see that all is in order. Check the tool kit as list on page 69.

Before running, see the car is supplied with fuel and water, that the engine and gearbox have the necessary quantities of oil and that the battery contains the proper amount of acid. See sections Lubrication and Electrical Equipment.

Cars delivered by road are ready for running. There is no oil, fuel or water in cars crated for overseas and the batteries are empty and uncharged.

Starting the Engine.

Make sure that the change speed lever is in neutral position and the hand brake on.

If the car has been standing for some time, starting should be assisted by using the hand priming lever on the petrol pump to give the carburetter a full supply of petrol.

Give the engine a few turns with the starting handle to make sure that the crankshaft is free (pushing the handle in to engage fully with the starting nut, before turning it). The ignition key is turned to the right to switch on the ignition and the charging and lighting switch is turned to "Summer Half Charge" or "Winter Full Charge."

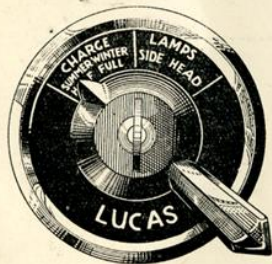

Never leave the ignition switch on for any lengthy period while the engine is not running. The warning lamp on the switch board will remind you of this.

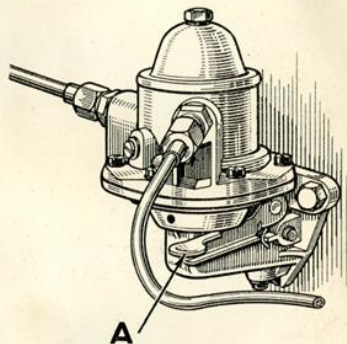

Petrol Pump Priming Lever (A)

Difficulty in Starting.

Difficulty in starting may be caused either through sucking too much petrol into the cylinders, or too little. When starting with the throttle all but closed, a strong suction takes effect on the pilot jet. If petrol is passing through the carburetter the suction can generally be heard.

If the engine fails to start quickly and there is a good deal of petrol overflowing from the carburetter, it is almost certain that the mixture getting into the cylinder is too rich. The throttle should then be opened half-way to reduce the suction. On firing, the engine will race, and the throttle should be almost closed. If the engine does not fire, close the throttle entirely, and try again.

After a stop in hot weather, failure of the engine to start is more likely to be due to a too rich mixture than one too lean, and one should stop the engine by the switch only after quite closing the throttle. Re-start the engine with the throttle closed.

If the starter does not turn the engine over readily, depress the clutch pedal before switching on. This will lessen the starting load, and so help the starter to turn the engine at higher speed.

If after the foregoing measures have been carried out the engine fails to start, the reason will probably be due to faulty ignition or carburation.

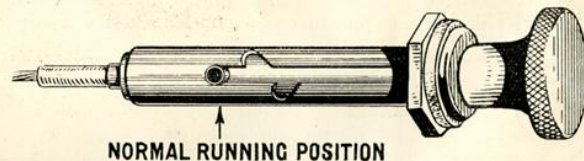

NORMAL RUNNING POSITION

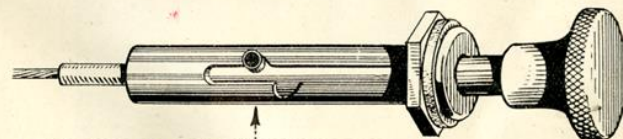

SLIGHTLY FASTER THAN IDLING SPEED

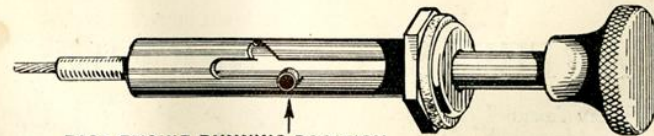

FAST ENGINE RUNNING POSITION

Combined Air Strangler and Throttle Control.

IGNITION: First examine the wires and see that the sparking plugs are connected. Then test the gap of the plug points by means of the thick end of the gauge provided in the tool kit. If the points are dirty, clean them before replacing the plug.

CARBURATION: The slow running jet may be stopped up or a main jet choked. Blow them out with a tyre pump. Never attempt to clean them by passing a wire or other small metal object through them. This will definitely injure the jets.

The engine should never be allowed to run at high speeds for the first 300 miles.

Speedometer.

The line of figures on the speedometer shows the total miles, or kilometres, up to 100,000. These figures then automatically return to zero.

The speedometer requires no lubrication or attention.

The Starting Handle.

When the engine is running, see that the starting handle is not hanging down. It should be replaced in a horizontal position at "9 o'clock" as shown below.

There is a catch which will secure it in its proper place there on the off-side of the car. This does not apply to certain models, including "Sports."

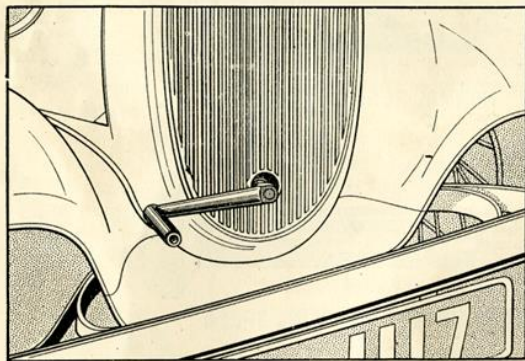

AFTER SALES SERVICE

Every Austin Dealer is under agreement to give to Austin Cars purchased from him "After Sales Service" during the period of the first 1,000 miles running of such cars.

Details of this service are enclosed in a separate envelope with every car.

CONTROL OF THE CAR

THE driving seat of the Austin Seven is adjustable for position and this convenience should be taken advantage of so as to obtain the greatest comfort.

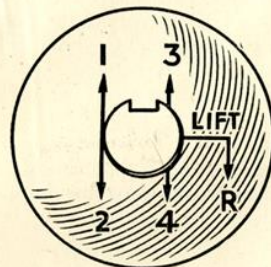

To engage first gear, push out the clutch and move the gear lever into the first speed position.

Sometimes it may happen that when the clutch is let in again, there is no apparent drive from the engine. That is because there has been no proper engagement of the gears. Therefore, push out the clutch again, and it will almost certainly be found that the lever can then be moved so as to give the proper gear engagement without using any force.

Start on first speed, accelerate to about 8 m.p.h., push out the clutch, move the lever to neutral, and continue the movement of the lever steadily to the second speed position and let in the clutch gently.

In moving from second to third speed, a similar action takes place. Accelerate to about 18 m.p.h., declutch, release the accelerator, move the lever to neutral and continue the movement of the lever steadily into the third speed.

To move from third to top, declutch, and move the lever steadily into the position desired. It assists the change from top to third, and third to second if the accelerator is held down while the change is made.

Change Early.

Always change gear early on a hill. Never allow the engine to labour in any gear and expect it to pick up speed on changing into a lower one when the car has nearly stopped. Do not persist in attempting to drive the car uphill in top gear when the speed falls below 18 m.p.h.—change down. If the car has been driven back by the reverse gear, wait until it is stationary before engaging a forward speed. Do not engage the reverse gear when the car is travelling forward. Serious damage to the gears will be the result.

Keep the foot off the clutch pedal except in heavy traffic. Even then do not allow the weight of the foot to be taken by the pedal. The slipping of the clutch caused by this practice heats and wears it badly.

When descending a long hill, or **before** commencing a steep descent, engage one of the lower gears, and do not accelerate.

The engine will then help to retard the speed of the car. When using the brake, keep the clutch in, disengaging it at the last moment if stopping the car.

REGULAR ATTENTIONS

ON this and the opposite page is a handy summary of all the attentions described in this handbook. The attentions under the daily, weekly, and monthly headings are based on the assumption that the maximum mileage per week does not exceed 500.

After the first few days' use tighten all nuts, particularly those on the engine cylinder head. These may loosen a little because of the heat generated, but if they receive this attention, both they and the head will remain secure against air or water leaks or loss of compression.

Under more strenuous conditions, for instance, very dusty or very muddy roads, long distances at high speeds or with heavy loads, it will be advisable to attend to the lubrication of chassis parts more frequently.

Warning.—After the car has been washed, or driven through water, the brake linings may be wet. Apply the brakes two or three times during the first few yards travelled, in order to dry them. Wet brakes may be dangerous.

Daily Attentions.

1. Examine water level in radiator and fill up to within one inch of the top.
2. Examine oil level in the crankcase and add more oil if necessary. The tell-tale dipper rod indicates the level of the oil. Change the oil first at 500 miles, then every 1500 miles. The sump capacity is half a gallon for standard models and three quarts for sports models.
3. Fill up the petrol tank if necessary. Care should be exercised not to overfill the tank which will contain five gallons.



Use only Recommended Oils.

Weekly Attentions.

1. With the grease gun charge—
Front spring shackle pins (4).
Front wheel swivel pins (2).
Steering cross tube (2).
Rear spring pins (2).
2. Oil the following—
Clutch release ring (oil lightly).
Steering side tube joints (2).
Foot brake pedal shaft (below steering box).
3. Examine both sets of brakes, and adjust if necessary.
4. Test the tyres for correct pressure and examine them for cuts, flints and nails.

Monthly Attentions.

1. Examine the oil level in the gearbox. It should be level with the filler plug. Capacity, $1\frac{1}{2}$ pints.

Change at first 1000 and then every 5,000 miles.

2. Charge the back axle case with special lubricant, using the adapter on the grease gun.

Change at first 1000 and then every 5000 miles.

3. Grease all the hubs, as described later.
4. Charge the steering worm case, through the nipple, with special lubricant.
5. Oil handbrake gear, pedal gear and joints, engine control joints, and top of steering column.
6. Examine the battery and see that the connections are tight.
7. Give a charge of the special grease to the nipple on the fan spindle.
8. Give a few drops of oil to distributor spindle bearing.
9. Grease the front end of the torque tube (behind the front seats).
10. Grease the splined end of the propeller shaft (behind the gear box). Turn the shaft and expose the nipples.

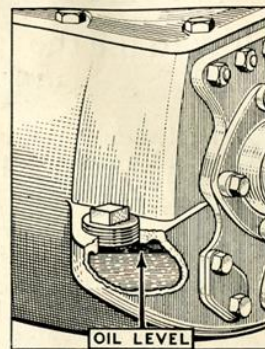

Occasional Attentions.

Examine all bolts and nuts, such as road spring clips, cylinder head nuts, wheel nuts, these three especially when the car is new.

Examine other parts, such as steering connections, the radius rod anchorage below the gearbox, and the torque tube socket, neglect of which might be followed by an expensive repair, and inability to use the car for a lengthy period.

Occasionally clean the petrol filter and float chamber strainers, and every 3000 miles the oil reservoir gauze (when the engine oil is changed). Also ensure that the oil jets in the crankcase are clean. Drain the gearbox and refill with fresh oil (about $1\frac{1}{2}$ pints) after the first 1000 miles, and then every 5000 miles.

Flush the radiator with plenty of clean water until it runs through clear. Clean the ignition distributor, and the contact breaker points (adjust the latter), the dynamo and starter commutators. Clean the shock absorbers, adjust the tappets, and the fan belt, decarbonize the engine and grind-in the valves. Check the alignment of the front wheels.

WHEELS AND TYRES.

How to use the Jack ; Correct Inflation Pressures

WHEN it becomes necessary to change a wheel because of a puncture or for any other cause, the first thing to do is to pull the handbrake "hard on." The spare wheel must be lifted from the rear of the car. Before it is used test the air pressures and if it is not up to the correct figure, use the pump to rectify it. The proper pressures are to be found in the section dealing with tyres.

It is important to have the car on level ground. With the wheel brace the three nuts (A) of the wheel to be removed should be slightly slackened, but only enough for them to unscrew freely later. The wheel is then jacked up.

If it is a rear wheel, the jack should be put in from the side, between the mudwing and the forward edge of the tyre, and should be placed under the rear spring between the two clips which embrace the spring leaves.

If a front wheel is to be attended to, first slacken the nuts by means of the wheelbrace. Place the jack under the front axle near but not under the big nut at the end.

The operating bar of the jack is in two parts, the upper part fits into the lower by means of a square tube and is secured in that position by a spring loaded ball.

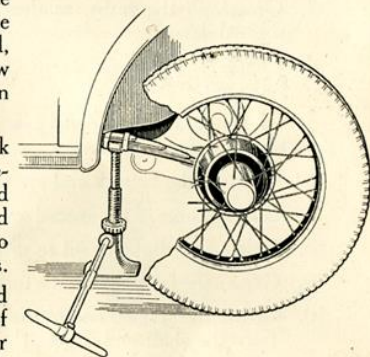

The head of this bar which engages with the jack must be pushed well home so that a spring loaded ball may engage with a slot which will prevent the head of the bar slipping out while the jack is in use.

The jack should be adjusted by hand as nearly as possible to the required height by turning the head round by hand before using the handle to lift the car.

To detach the wheel from the hub loosen the three nuts by

means of the brace ; it is not necessary to remove them entirely. Pull the wheel outwards about $\frac{1}{4}$ in. and turn it a little to the left so that the large hole will pass over the nut. The wheel can now be pulled off the hub.

When replacing make sure that the large holes in the wheel centre are properly fitted over their pegs, and tighten the wheel nuts, each only a few turns at a time, until they are quite tight and secure.

Should difficulty be experienced upon the first occasion of removing the wheel from the hub, the wheel nuts may be screwed right off. Before replacing, wipe the outside of the brake drum and inside of the hub with an oily rag as this will ease the removal on future occasions.

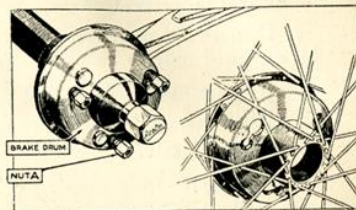

Do not detach nut A. The wheel will slide over it.

Care of The Tyres.

The key to economical and efficient tyre service is to maintain the correct pressures and test your tyres at least weekly. Any loss of air pressure can be made up with very little effort.

A gauge applied to the valve must be used, for it is seldom possible to detect under-inflation from the tyres' appearance.

Minimum pressures to which tyres should be inflated are :—

Tyre Size.	Front Tyres.	Rear Tyres.	
		One or two Passengers.	Fully Laden
3.50—19	22	22	—
4.00—17	22	22	26
4.00—18	22	22	26
4.75—16	18	18	22
		Lbs. per sq. in.	

A tyre that loses more than three to four lbs. per sq. inch in a week should be regarded as "suspect." First, make sure that a new valve inside is not required. If the tube is punctured make sure before refitting that the puncturing object is not still embedded in the cover.

It is important that both front tyres be kept at same pressure. If, because of wear or other causes, the steering develops a tendency to wander, or show signs of wobble, the front tyre pressures should be increased.

Dirty Tyres.

Oil, paraffin and grease are injurious to rubber, and should be removed as soon as possible by the use of a clean cloth and a very little petrol.

Cuts and Damage.

Damage affecting only the rubber tread and walls may be plugged with a good tread cut filling. If this is done promptly an extension of the injury will be prevented.

Damage of a more serious nature affecting the cotton structure should be entrusted only to an expert tyre repairer or the tyre manufacturer.

It is essential that the tyre be removed immediately the damage is sustained.

Uneven Wear.

Because the front wheels are "cambered," or lean outwards, the outer side of the tyre tread wears more rapidly than the inner. To minimise the effect of such wear, turn the tyres, say every three or four thousand miles, so that the more worn sides are next to the car.

At the same time, exchange the near and offside tyres so that the unequal weight distribution and consequent wear caused by road camber are shared.

If the front tyres begin to wear rapidly, have the tracking of the front wheels checked immediately and, if necessary, adjusted. (See pages 61 and 62).



DON'T

- Don't leave the car in gear with the handbrake off.
- Don't make a fast run with the radiator muff down.
- Don't fill the radiator with cold water when the engine is hot.
- Don't try to turn the engine without first pushing the starting-handle in to engage fully with the starting nut.
- Don't be cruel to the starter if the engine will not fire.
- Don't put an excessive quantity of lubricant in the gear box.
- Don't forget the ignition key when starting up.
- Don't forget to withdraw the ignition key when the engine is not running.
- Don't coast with the engine running and the clutch held out.
- Don't run the engine in a closed garage. (The exhaust gases are highly toxic and a very small amount in a restricted atmosphere will produce grave, if not fatal, results).

THE PETROL PUMP.

How Fuel is supplied from the Tank to the Carburetter

PETROL is drawn from the tank at the rear by means of an A.C. petrol pump which advances the fuel in the correct quantity demanded by the carburetter, no more and no less.

Service of the petrol pump is available at all Austin Dealers and at all A.C. service stations, which are prepared with parts and fixtures for repairing and adjusting all pumps if any trouble is experienced with the fuel supply.

Make sure that any difficulty is not due to causes apart from the pump before attempting to do anything to the pump.

If there appears to be lack of fuel at the carburetter, first ascertain if there is any fuel in the tank, and if not, replenish. Make sure that the tubing and connections between the tank and the pump, and between the pump and the carburetter, are not leaking, and in case of broken or damaged tubing replacement should be made.

It may be that the filter cover of the petrol pump is loose. If this is the case, tighten the main nut at the top, first ascertaining that the cork gasket lies flat in its seat and is not broken or unduly compressed. A gasket compressed hard may need to be replaced.

Clean the Filter.

Occasionally remove the cover and clean the filter screen underneath it. Also remove any sediment over the chamber below the filter.

When re-assembling, take care that the cork gasket is replaced correctly, the fibre washer on the head of the screw.

If petrol appears to be leaking at the edge of the diaphragm tighten the cover screws alternately and securely, but do not attempt to dismantle the pump body.

Sometimes there appears to be a leakage of fuel at the diaphragm union. The leakage may actually exist at one of the pipe fittings and the fuel has run down to the pump and the diaphragm flange.

In hot weather when petrol is likely to evaporate, and when difficulty might be expected on cold mornings it is advisable to fill the carburetter by operating the hand priming lever on the pump before attempting to start the engine.

The pumping action of the diaphragm can be distinctly felt until the carburetter bowl is full.

After removal of the upper casting on any type of A.C. fuel pump it is important that the cover should only be replaced while the pump pull rod is at the top of its stroke. This is to ensure sufficient flexing of the diaphragm to allow its normal working movement.

How it works.

By revolving shaft (G) the eccentric (H) will lift rocker arm (D) which is pivoted at (E) and which pulls the pull rod (F), together with the diaphragm (A), downward against the spring pressure (C), thus creating a vacuum in the pump chamber (M).

Fuel from the rear tank will enter at (J) into sediment chamber (K) and through the filter gauze (L) and suction valve (N) into pump chamber

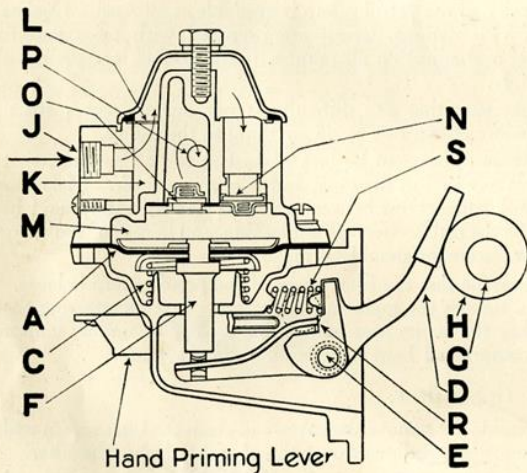

The A.C. Petrol Pump.

(M). On the return stroke spring pressure (C) pushes the diaphragm (A) upward, forcing the fuel from chamber (M) through pressure valve (O) and opening (P) into the carburetter.

When the carburetter bowl is filled the float in the float chamber will shut off the inlet needle valve, thus creating a pressure in pump chamber (M). This pressure will hold diaphragm (A) downward against the spring pressure (C) and it will remain in this position until the carburetter requires further fuel and the needle valve opens.

The rocker arm (D) is in two pieces, the outer one operating the inner by making contact at (R) and the movement of the eccentric (H) is absorbed by the "break" when fuel is not required.

Spring (S) is merely for the purpose of keeping the rocker arm (D) in constant contact with the eccentric (H) to eliminate noise.

ZENITH CARBURETTER

Cleaning and Adjustment for good Performance

THE carburetter fitted to the Austin Seven is the Zenith "V" type, embodying the well known principles of main and compensating jets.

Petrol from the pump passes through the union, the filter and the needle seating into the float chamber. As the float rises it will close the needle on its seating, thus regulating the flow of the petrol.

The float chamber contains the main jet, the compensating jet, the compensating well, and the slow running jet. Petrol flows through the main and compensating jets and also rises in the compensating well. From the jets it flows along two separate channels into the emulsion block attached to the float chamber.

Petrol in the compensating well is in direct communication with the air and with the emulsion block, and the emulsion block leads to a nozzle which projects into the choke tube.

Starting the Engine.

To obtain an easy start from cold the combined throttle and strangler control on the dashboard should be extended to its third position, and the engine should be given, by hand, a few turns to free the working parts. Then pull the self-starter control knob and when the engine is running release the strangler control to the first notch.

In cold weather it may be necessary to hold the strangler control out for a few minutes while the engine warms up, and to run the car for the first few minutes with the knob in the first notch. As soon as the engine is warm, however, the control knob should be pushed right in, otherwise the mixture will be too rich.

If difficulty in starting the engine is experienced, ascertain that the strangler flap is closing properly and if necessary adjust the wire.

A choked slow running jet will also cause difficulty. The jet should be cleaned only by blowing through it, either with a pump or orally.

Trouble can also be experienced if the throttle is not open sufficiently when the strangler knob on the dash is on the first position. In this case turn the adjusting screw a little to the right to open the throttle wider.

If the engine does not idle as slowly as desired, turn the screw to the left to close the throttle slightly.

A weak mixture may cause difficulty in slow running and this may be adjusted by turning the regulating screw clockwise to enrich the mixture. Do not make the mixture too rich or the engine will "hunt," or will tend to choke when slow running while warm.

Adjustments.

No adjustments should be carried out unless absolutely necessary.

If the engine is positively poor in accelerating when it is running at a sufficiently warm temperature, and the adjustments described will not remedy the trouble, it may be desirable to fit a larger compensating jet.

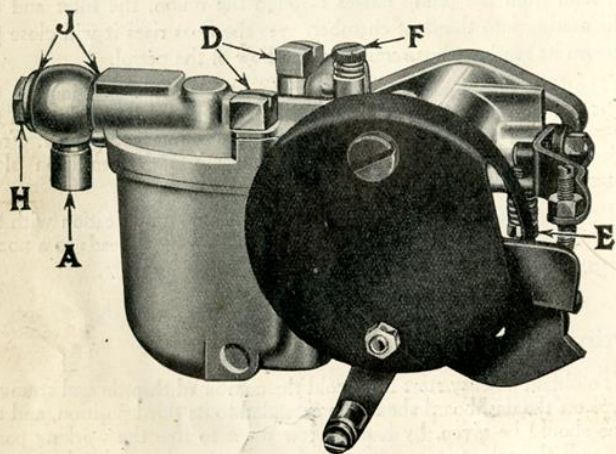

V Type Zenith Carburettor.

- | | | |
|-----------------------|------------------------|---------------------|
| A Union | E Stop screw | H Petrol connection |
| D Holding Down Screws | F Air Regulating screw | J Washers |

If there is a lack of power and speed, this may be due to the main jet being partially choked, or if greater power is desired a larger size main jet may be fitted.

Make sure that the strangler valve opens fully, for if this sticks in a partially closed position it will restrict the speed of the car and increase petrol consumption.

Do not, however, alter the jets unless you are quite sure that other parts of the engine, including sparking plugs, ignition and valves are in order, and that compression is good. There are no moving parts in the Zenith carburettor, so that nothing can get out of adjustment when once set.

Cleaning.

The bowl of the carburettor should be removed occasionally for cleaning. Take out the two holding down screws and the bowl will drop into the hand. On turning the bowl upside down the float will fall out and reveal the jets at the bottom of the bowl.

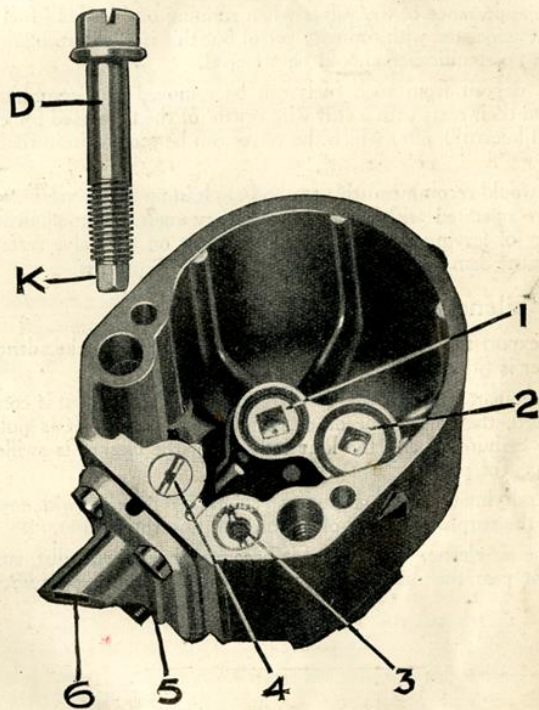

The Carburettor Bowl.

- | | |
|-------------------------------|--------------------|
| 1 Main jet | 2 Compensating jet |
| 3 Compensating well | 4 Slow-running jet |
| 5 Emulsion block | 6 Nozzle |
| D Holding-down screw | |
| K Squared end to form jet key | |

The jets are removed by fitting into them the squared end of one of the holding down screws and using a spanner on the other end. To clean the jets wash them in petrol, and blow through them to remove obstruction. Do not use wire.

Sizes of Zenith jets run in 5's—the larger the number the larger the jet.

The connection from the petrol pump should be dismantled and the filter thoroughly cleaned in petrol. When reassembling take care that the washers on either side of the union are correctly replaced.

"Leaded" Fuels.

Provided that the same reasonable attention is given to the valves and other adjustments as with ordinary petrol there will be no trouble when using "leaded" fuel (petrol containing a small proportion of tetraethyl lead).

The appearance of the valves when running on "leaded" fuel differs from that associated with ordinary petrol but this is a well recognised fact to which no significance should be attached.

The deposit from such fuels can be removed by "scrubbing" the valves and their seats with a stiff wire brush of the type used for cleaning files (a "file card"), after which the valves can be ground-in in the normal manner.

We would recommend this method of cleaning for all valves, whether they have operated with leaded or ordinary fuels, as it eliminates the possibility of leaving small amounts of deposit on the valve seats which tend to cause damage or prolong the "grinding-in" process.

Intake Silencer.

On export models an A.C. oil wetted carburetter intake silencer and air cleaner is fitted.

At frequent intervals, say weekly in countries where dust is constantly experienced, the silencer needs cleaning and re-oiling. It is pulled off from the carburetter and the louvered end of the cleaner is swilled in a shallow pan of petrol.

After drying the metal gauze mesh should be re-oiled with engine oil, allowing the surplus to drain off before refitting the cleaner.

If the air cleaner is neglected it becomes choked with dirt, sufficient air cannot pass, the mixture is too rich, and the petrol consumption is increased.

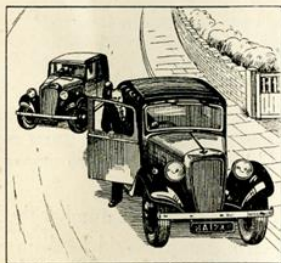

Be sure the
road is clear
before opening
a door.

"NIPPY" SPORTS MODEL

Hints on Tuning the Carburetter and the Engine

THE "Nippy" Sports Model has a specially tuned engine and is provided with a positive gear pump which forces lubricating oil under pressure to the main and the big-end bearings and the camshaft bearings.

The oil reservoir should be drained after the first 500 miles and the oil should be completely changed after every 1,500 miles running.

Suitable lubricants are :—

Summer : Mobiloil D ; Wakefield Patent Castrol XXL ; Aero Shell ; Essolube Racer ; Motorine B de Luxe ; Duckham's Aero NP3.

Winter : Mobiloil BB ; Double Shell ; Patent Castrol XL ; Essolube 50 ; Motorine C de Luxe ; Duckham's Aero NP3. Extreme Cold : Duckham's NP2.

Other details on lubrication instruction appear later in the book.

The maximum speed of the engine for safety is approximately 4,500 revolutions per minute.

The Carburetter.

The special carburetter fitted is a downdraught Zenith 30 V.E.I. It embodies the well-known Zenith principles of main and compensating jets and is mounted at the top of the inlet pipe in order to take advantage of gravity to assist carburation.

Petrol passes through a filter into the float chamber, which holds the main jet, the compensating jet, the slow running jet and the capacity tube. The float, rising in the chamber, causes the needle to stop the flow of petrol, thus regulating the supply.

Passing through the main and compensating jets the petrol rises in the compensating well, which contains the capacity tube and is in direct communication with the atmosphere at the top and the emulsion block at its bottom outlet.

Petrol will flow along the channel underneath each jet into the emulsion block and to a nozzle which projects directly into the choke tube. Issuing from the nozzle the mixture will strike a bar fixed in the choke tube, which has the effect of thoroughly atomizing it.

There are no moving parts in the carburetter to require adjustment, but it is necessary to occasionally clean the filter and the bowl.

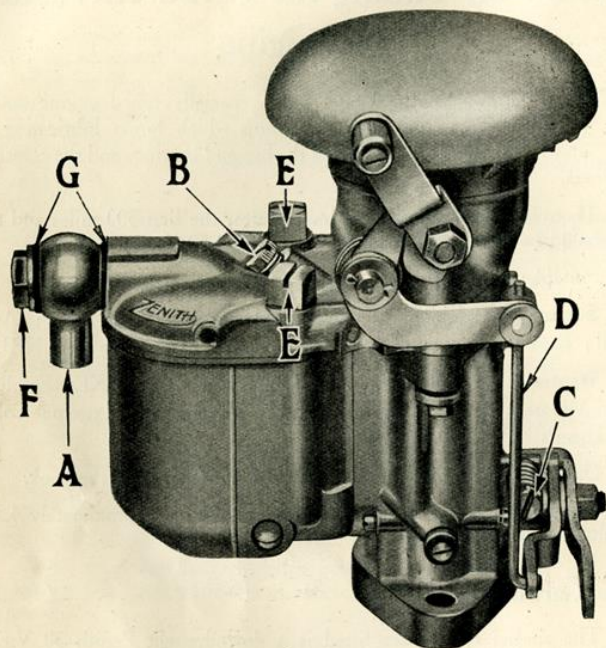

Downdraught Carburetter.

- | | |
|-------------------------------------|---------------------------|
| A. Union | E. Holding down screws |
| B. Slow running air adjusting screw | F. Petrol connection pipe |
| C. Throttle arm stop screw | G. Washers |
| D. Connecting link | |

The bowl is removed from the carburetter by taking out the holding down screws and the jets may be withdrawn by using the screw with the squared end and a spanner. A small screwdriver will remove the slow running jet and the capacity tube.

Do not attempt to pass wire through the jets but clean them by blowing, either orally or with a pump, and rinse them in petrol.

Standard adjustments are:—

Choke Tube	21
Main Jet	85
Compensating Jet	55
Slow Running Jet	60
Needle Seating	1.5
Capacity Tube	2
Progression	90

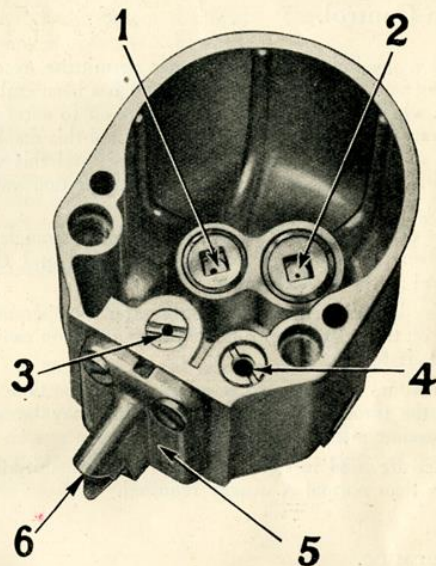

Carburetter Bowl.

- | | |
|--------------------|------------------|
| 1 Main jet | 4 Capacity Tube |
| 2 Compensating jet | 5 Emulsion Block |
| 3 Slow running jet | 6 Nozzle |

The main jet has the greatest influence on high speeds and governs maximum power. The capacity tube controls acceleration from low speeds, low speed pulling on hills and starting up from cold. The slow running jet measures the petrol when the engine is idling.

Smooth regular slow running will be provided with the slow running adjustment screw (B) set approximately one complete turn open when the engine is quite hot. Idling speed can be regulated by the throttle arm stop screw (C). Turn this clockwise to increase speed.

In case of difficulty with slow running, ascertain that the slow running jet is not obstructed, and check the position of the slow running adjusting

screw, and the throttle arm stop screw. Continued difficulty may be traced to air leaks at the inlet pipe, or to valves or faults in the ignition system.

Easy starting from cold is assisted by the automatic air strangler interconnected with the throttle lever. The strangler is situated in the air intake of the carburetter and is closed by fully extending a dashboard control. By means of the interconnecting mechanism this operation sets the throttle open just the correct amount to ensure an easy start.

Diaphragm Control.

To avoid a possibility of the strangler permitting excessively rich mixture passing into the cylinders a diaphragm has been embodied in the strangler flap, which will open and permit extra air to enter immediately the engine fires. The quick opening and closing of this diaphragm when the engine is running will cause a buzzing noise, and this will serve to remind the driver that the strangler is still in operation and should be released.

In case of difficult starting ascertain that the air strangler flap closes completely when the dashboard control is operated and that there is sufficient petrol in the float chamber.

Petrol may be pumped into the carburetter by operating the hand priming lever on the petrol pump. The pumping action can be felt until the carburetter is full.

It is sometimes necessary to re-adjust the connection between the strangler and the throttle. The connecting link may be shortened to increase the opening of the throttle.

When cars are used in hot climates or at high altitudes a slightly weaker setting than normal is usually required.

Valve Clearance.

It is important that the valve tappets should have correct clearance to obtain a good performance.

The most efficient setting is that which gives a clearance of .004in. when the engine is very hot.

As it is difficult to make the adjustment under these conditions without damage or accident the tappets should be adjusted when cold to give a clearance of .008in. for inlet valves, and .010in. for the exhaust valve.

Good performance cannot be expected unless the valve tappet clearance is correct and the valves and valve seats are in good condition.

Great care should be taken when decarbonising the engine to clean the valve stems thoroughly and grind-in the valve face efficiently. A top overhaul is called for more often on the sports model than on the ordinary touring car.

THE COOLING SYSTEM.

Precautions to take against Freezing and Overheating

THE cooling of the engine is maintained by a capacious radiator which should be filled with rain water if available, up to within about one inch of the top of the filler. The capacity of the radiator, pipes and cylinder jackets is 9-10 pints.

In Winter an anti-freezing mixture should be added to the water in the radiator, because in very severe weather the water may freeze and thus damage the cylinder block or the radiator itself. Moreover, when an anti-freeze mixture is used, there is no need to draw off the water to prevent damage by frost.

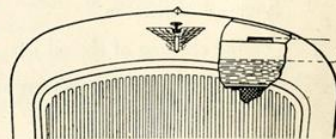

Vacuum "Voco Anti-Freeze," Smith's "Bluecol," Price's "Zero," and County Chemical "Stop-it-Freezing," are suitable.

If such a mixture is not used, care should be taken to see that the water is drained off completely, for, in case of freezing, it will do harm by lodging in small spaces, and fracture of the cylinder block may result. In Great Britain the climate does not very often call for the cooling system to be drained, but it is well to err on the right side and take due precaution against damage if frost be threatened.

Freezing.

In frosty weather freezing may occur first at the bottom of the radiator or in the lower hose connection. It is sometimes possible to feel ice in the hose and break it by squeezing.

Ice in this hose will stop water circulation and may cause boiling.

Before using anti-freeze mixture tighten the cylinder-head nuts to make sure that none of the mixture gets into the cylinders. The mixture may do considerable damage if it contaminates the engine oil.

Flushing.

To prevent the gradual formation of deposits in the cooling system, with consequent impeding of the circulation, the use of hard water should be avoided. Soft water, rain-water (syphoned from the top of the barrel where it is clean) or, failing that, water that has been boiled, should be used.

Occasionally flush out the water cooling system by opening the drain cock at the bottom of the radiator and allowing water to run through until it comes out clear.

Causes of Overheating.

Overheating may be attributed to one or more of the following causes :—

Slack fan belt. The belt can be tightened by turning the fan spindle in its bracket after loosening the clamping-nut.

Excessive carbon deposit in cylinders. See "Running Adjustments"

Running with ignition too far retarded.

Using oil of poor quality, or lack of oil in the reservoir. See "Engine Lubrication."

Partial choking of the oil jets. See "Engine Lubrication."

Improper carburetter adjustment, giving a mixture too rich or too weak. See "The Carburetter."

Failure of water to circulate, because of choked radiator tubes, water level below the tops of the radiator tubes, or loss of water through leakage from connections.

Overcooling is almost as bad as overheating. If the engine tends to be too cool, use a radiator muff.

Trouble arising from a damaged radiator generally necessitates its dismantling and despatch to a repair depot.



THE IGNITION SYSTEM

Cleaning the Distributor ; Lubrication ; Fault Finding

THE Coil Ignition Equipment is provided with an automatic advance mechanism, which relieves the driver of the necessity of constant adjustment of the hand ignition control. Its advantages are particularly evident when accelerating, and during hill climbing, the danger of pre-ignition, knocking or "pinking" being very much reduced.

The device is housed in the distributor body and it consists of a centrifugally operated mechanism by means of which the ignition is advanced in proportion to the engine speed.

Very little attention is needed to keep the ignition equipment in first-class condition ; we advise that it is inspected occasionally and the following instructions on lubrication, cleaning and adjustment should be carried out.

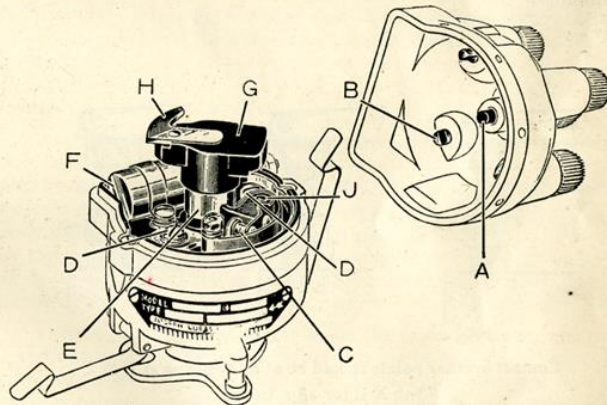

Distributor and Contact Breaker.

A Carbon Brush	D Locking Screws	G Rotating distributor arm
B Electrode	E Rotating Cam	H Metal Electrode
C Contacts	F Condenser	J Contact breaker pivot

The Distributor.

The distributor cover can be removed on springing aside its two securing clips. The electrodes "B" and "H" and the inside of the cover are then accessible for cleaning with a dry duster. See that the carbon brush "A" is clean and moves freely in its holder. The contact breaker points can be similarly cleaned if required.

Normally the gap between the contacts will not require adjustment until a considerable mileage has been covered, unless the points have burned. The work of re-setting the points, when this has occurred, should be left to a skilled mechanic. For the normal adjustment, first turn the engine by the starting handle until the points are seen to be fully open. Then, using the ignition screwdriver, slacken the two screws "D" in the contact plate, and move the plate until the gap is set to the thickness of the gauge. After making the adjustment care must be taken to tighten the locking screws.

The Coil.

The coil needs no attention apart from keeping the terminals tight and the top clean.

Ignition Switch and Warning Lamp.

The key, by means of which the ignition is switched on, should be withdrawn when the engine is not running. This will ensure that the battery does not discharge by the current continuing to flow through the coil windings.

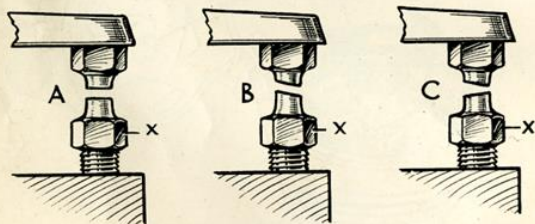

Contact breaker points should be as at A, not as at B or C.
Nut X is for adjustment.

The warning lamp on the instrument panel will light when the ignition is switched on and the engine is not running. This lamp also lights when the engine is only idling. Should the bulb of the warning lamp fail this will not affect the ignition, but it should be replaced as soon as possible so as to act as a safeguard to the battery. It can be removed from its socket when the small cover plate holding the red glass is unscrewed. The replacement bulb should be a 2.5 volt .2 amp. screw cap type (No. 252 M.E.S.) as originally fitted.

Lubrication.

The distributor spindle bearing is lubricated by means of an oiler which needs a few drops of oil every 1,000 miles.

Every 3,000 miles, give the cam the slightest smear of vaseline and place a single drop of oil on the pivot "J" on which the contact breaker works. Withdraw the rotating arm "G" from the top of the spindle by lifting it off, and add a few drops of thin oil to the top of the spindle. Do not remove the screw exposed to view, as there is a clearance between the screw and the inner face of the spindle through which the oil passes to lubricate the automatic timing control. Take care to refit the arm correctly and to push it on to the shaft as far as possible.

High Tension Leads.

When the high tension cables show signs of perishing or cracking, they should be replaced. Use only 7 m.m. rubber covered ignition cable for all high tension leads.

To make a connection to the distributor or coil terminals, thread the knurled insulating nut over the lead, bare the end of the cable for about $\frac{1}{4}$ of an inch, thread the wire through the brass washer provided, and bend back strands. When the moulded nut is screwed home, the cable will be securely clamped, and the nut will support the cable, and prevent vibration and fracture.

Ignition Faults.

When the engine will not fire, or fires erratically, the trouble may arise from the carburetter, or petrol supply and not the ignition. A partially choked jet, an incorrect petrol level, or air leaks into the induction system may be the faults. Equally, sooted plugs can be suspected, when dismantling and cleaning them will remedy the trouble. If the battery has run down, or its terminals have worked loose, quite obviously there will be no spark, and the same results can be expected if the distributor electrodes and contact breaker have been neglected and are dirty.

The coil can be tested by removing the cable from the centre socket on the distributor cover, and holding the end of this cable about $\frac{1}{4}$ inch from some metal part of the car while the ignition switch is on and the engine is turned. A strong and regular spark will result if the coil is in order. Clean the top of the coil, and ensure that its terminals are tight before making this test.

Short Circuits.

To test for short circuits in the low tension wiring (the cables from the switchboard to the coil, coil to distributor, and distributor to chassis) which would equally cause irregular running, have the engine turned while the ignition is switched on, and watch the ammeter reading. It should rise and fall as the contact breaker points close and open. This test will also indicate if the contact breaker is functioning correctly. If the contacts remain open, or do not fully close, the reading will not fluctuate.

If the high tension cables from the distributor to the plugs are not securely attached to the distributor, misfiring may occur. Or, if the rubber insulation on these cables shows signs of perishing and cracking, there may be leakage of the current giving rise to the same symptoms. Renewing the cables is then the remedy.

If, after verifying these points, the trouble remains undiscovered, the equipment should be examined and tested by the nearest service depot of the makers.

Timing the Ignition.

In order to reset the ignition timing turn the crankshaft until No. 1 piston is at top dead centre before a firing stroke. This can be ascertained by watching the valves or by removing the floorboards and the clutch pit cover. Top dead centre is marked on the flywheel 1/4.

Turn the flywheel back about $\frac{3}{4}$ in., and, having removed the distributor cover, slacken the screw for the clip to the distributor casing and turn the casing until the contact breaker points just begin to open. This is the position at which the spark occurs in No. 1 cylinder.

Tighten the adjusting screw, refit the distributor cover and test the car on the road. If the ignition seems too far advanced or retarded it can be finally adjusted at the distributor. There is a considerable amount of latitude for adjustment but only extremely small movement should be made at one time.

If the leads from the distributor to the sparking plugs have been disconnected they must be replaced in the firing sequence marked on the cover, 1, 3, 4, 2.



THE SPARKING PLUGS

THE sparking plugs with which the Austin "Seven" is fitted are K.L.G., type 777, manufactured by K.L.G. Sparking Plugs, Ltd., Putney Vale, London, S.W. 15. They are three piece plugs.

The gaps between the firing point of the central electrode and the earth points are set at .015 to .018 of an inch. A too wide gap would cause misfiring, especially at high speeds and under heavy pulling at low speed with an open throttle, while a too small gap causes poor idling.

After the first thousand miles it may be necessary to clean the plugs, because an excessive amount of oil is sometimes used and this causes a deposit of carbon on the interior insulation of the plugs.

Type 777 is a three-piece plug—the gland nut is a separate component. To clean a plug, the insulated centre A must be removed from the plug body C by unscrewing the gland nut B.

When B is unscrewed the central electrode may be withdrawn. Wipe the lower mica insulation carefully with a petrol soaked rag. If the carbon deposit is hard, soak the electrode in petrol for an hour or so, this will soften the carbon. The mica insulation D should be thoroughly cleaned and polished, and the central electrode scraped clean.

Scrape out the inside of the body and clean the earth points. Wash the plug body in petrol and dry it.

To reassemble, see that the internal washer is in place before inserting the electrode. Tighten the gland nut to secure gas tightness, reset the earth points E to .015—.018 in. To do this it may be necessary to bend each earth point toward the central electrode.

The central electrode must not be levered toward the earth points.

A gauge is supplied in the tool kit.

If the sparking plug washer has been completely flattened, replace it with a new one.

Poor grade oil, improper carburettor adjustment, low grade petrol, excessive use of choke, faulty cables, distribution points out of adjustment—all these may cause fouled sparking plugs.

Sparking plugs should be renewed every 10,000 miles.



LUBRICATION

Use only the Recommended Oils and Greases

THE correct lubrication of any piece of machinery is of the utmost importance, but for the modern high-speed automobile engine, which operates at sustained high temperatures and speeds, it is absolutely essential that only oils of the highest quality and correct grade be used. Inferior oils, or unsuitable oils, will almost inevitably cause excessive wear in an unduly short time.

We cannot over emphasise the folly of using so-called "cheap" lubricants.

Modern cars use comparatively little oil, so that the cost of using a good lubricant is negligible compared with the cost of using inferior oil. Good lubricating oil ensures that you always get out of your car the best performance that it can give; it reduces carbon deposit, making frequent decarbonising unnecessary; it makes starting easier, thereby avoiding deterioration of the battery; it reduces engine wear and eliminates avoidable causes of mechanical breakdown with possible heavy repair bills.

Lubricants represent the smallest proportion of your expenditure on the upkeep of a car, so that it is obviously false economy to use other than the best.

Impurities.

But even the best oil becomes contaminated with certain impurities during use. In the engine, these may be unburnt fuel, carbon, metallic particles, moisture, etc., and although the oil itself does not deteriorate the presence of these impurities must reduce its efficiency as a lubricant and in time cause avoidable wear. Oils of the best quality resist contamination, and consequent wear, to the greatest extent. Nevertheless it is imperative that the crankcase be drained periodically to remove foreign matter, and subsequently refilled with fresh clean oil.

Drain the crankcase immediately after a run when the oil is warm, and therefore fluid and thoroughly agitated. It will then carry away as much of the contamination as possible. Never flush the crankcase with paraffin—some will remain in the sump to contaminate the fresh oil, and, in addition, it may loosen, but not entirely remove, certain deposits which are best left undisturbed until the engine is overhauled.

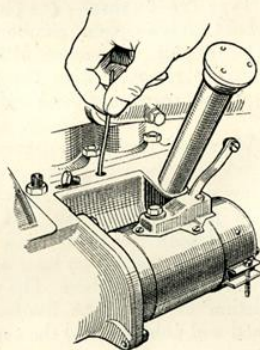

Cleaning the Oil Jets.

Rinse gauze filters in petrol and allow to drain before refitting. **Do not wipe with fluffy rags.**

Oil in the gearbox and back axle becomes contaminated with metallic particles from the gear teeth and these will cause unnecessary wear of the bearings unless removed. These units should also be drained periodically and may be flushed with a thin oil. This should be allowed to drain thoroughly, after which the unit should be filled to the correct level with fresh oil.

Choice of Lubricants.

Some lubricants are lighter in colour and appear thinner than others. However, the colour of an oil or its appearance at atmospheric temperatures give no indication as to its efficiency under operating conditions and temperatures. Therefore, oil should never be judged by colour or apparent consistency.

The various lubricants which we officially recommend, each of them having the high grade standard of quality required by our Research Department, and all of them having proved entirely satisfactory in extended service, are tabulated on the next page. They all have adequate distribution at garages and filling stations.

The Engine.

The recommended lubricants are of the correct quality and viscosity for our units. The matter of the proper grade of oil is very important both in relation to the pump used to circulate the oil, and the gauge to register the pressure; if a very thick oil were used on a cold day, the pump might be strained or the gauge broken.

After the first 500 miles, drain the original oil from the reservoir by removing the plug in the bottom, while the engine is hot, and refill with new oil. The sump capacity is half a gallon for standard models and three quarts for sports models.

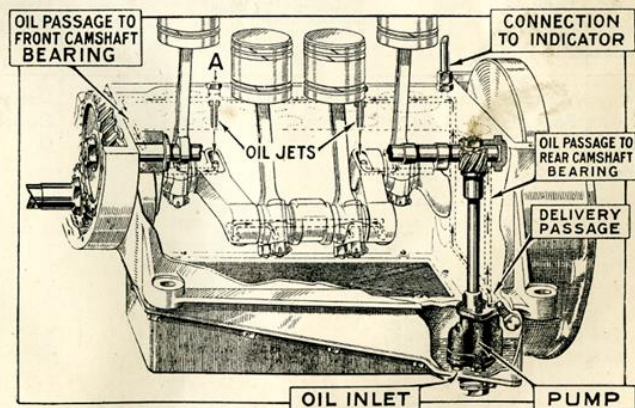

Recommended Lubricants

	"Vacuum"	"Shell"	"Wakefield"	"Anglo-American"	"Prices"	"Duckham's"
Engine :						
Summer ..	Mobiloil BB	Triple	Castrol XL	Essolube 50	Motorine C	Aero NP3
Winter ..	Mobiloil A	Double	Castrol AA	Essolube 40	Motorine M	Aero NP3 (or NP2)
Gear Box ..	Mobiloil BB	Triple	Castrol XL	Essolube 50	Motorine C	Aero NP3
Wheel Hubs and Grease Gun	Mobilgrease No. 4	Shell R.B. Grease	Castrolase Heavy	Esso Grease	Belmoline C	H.B.B. Grease
Rear *Axle and Steering Box	Mobiloil C	Spirax	Castrol D	—	—	—
Distributor, Dynamo and Oil Can.	Gargoyle Velocite D	Shell Household	Wakefield Oilit	Essolube 30	Cycle Lubricating Oil	Aero N.P.O.
Upper Cylinder Lubrication.	Gargoyle U.C.L.	Shell U.C.L.	Wakefield Castrollo	Petmix	Motorine U.C.L.	Duckham's Tablets.
Springs, Rusted Parts or Squeaks.	Voco Penetrating Oil	Shell Penetrating Oil	Castrol Penetrating Oil	Essolube 30	Price's Penetrating Oil	Duckham's Easing Oil

* Also Jaba Oil C

Austin "Seven" Lubrication

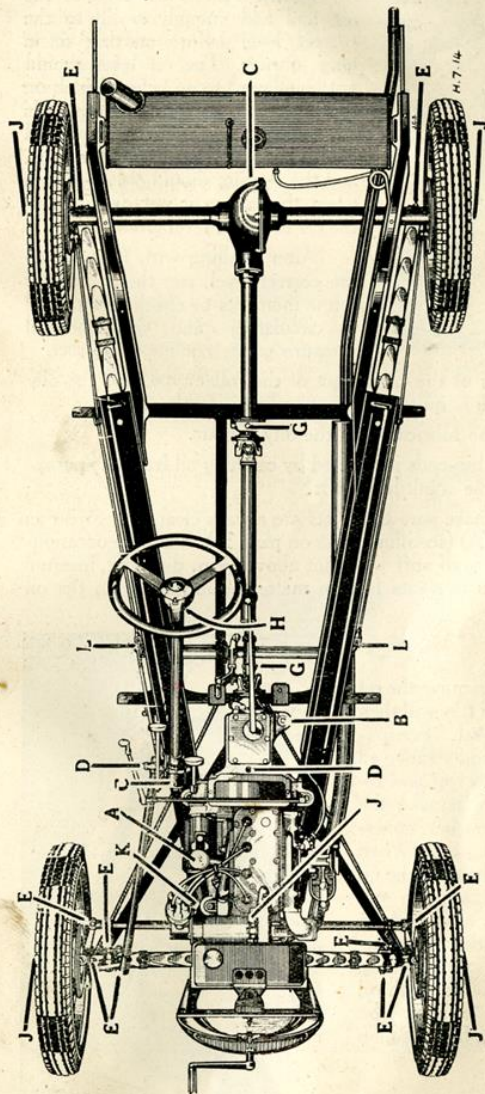

- A. Crankcase. Replenish to full mark on dip-stick **weekly**.
- B. Gearbox. Replenish **Monthly**.
- C. Rear Axle and Steering Box. Replenish **Monthly** —Special Oil.
- D. Clutch withdrawal sleeve and steering side tube. Oil **Weekly**.
- E. Cross tube (2), Swivel axle (2), Spring shackles (6). Grease **Weekly**.
- G. Torque tube, front end, Propeller shaft, splined end. Grease **Monthly**.
- H. Top of steering column. Oil **Monthly**.
- J. Hubs and Fan bearing. Grease **Monthly**.
- K. Distributor. Oil (sparingly) every 1000 miles.
- L. Brake and throttle control joints, and brake pedal shaft. Oil **Weekly**.

After the first re-filling it is advisable to change the oil in the engine entirely after every 1,500 miles running.

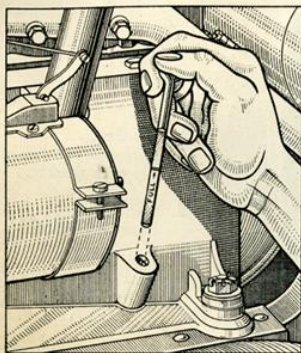

Always inspect the level of the oil, and add enough to fill to the correct level before starting on a long journey. The oil level should not be allowed to go below $\frac{1}{4}$ inch on the bottom of the dipper rod. It is advisable to wipe the dipper rod before taking the reading of the level, and the reading should only be taken when the engine is not running and the car is on the level ground.

After refilling with fresh oil to the correct level, run the engine for a few moments to check that the oil is circulating and that the oil pressure gauge reading is correct.

The main bearings of the engine are of the roller type, and the oily vapour in the crankcase is quite sufficient to lubricate these.

The pistons are also lubricated by the oily vapour.

Lubrication of the big-ends is effected by catching oil from the pump-jets in pockets on the crankshaft webs.

It is advisable to make sure these jets are always clear, and to do so the plugs over the jets (A) (see illustration on page 35) should be occasionally removed and a piece of stiff wire, not above $\frac{1}{8}$ in. diameter, inserted through the jets. This prevents foreign matter accumulating in the oil jets and choking them.

Every 3,000 miles remove the oil reservoir. The gauze oil tray will then be accessible for removal. Scrupulously clean the gauze and remove all dirt from inside the reservoir and replace them. Carefully remake the joint with the packing washer, covering both sides of it with grease. When tightening up the nuts holding the oil reservoir to the crankcase, do not pull up one nut tight, but tighten each nut equally, a little at a time. See that the drainplug is screwed up tight, then fill the crankcase with oil to the maximum level as shown on the dipper rod. About half a gallon will be enough to fill.



Oil Gauge.

The oil pressure gauge records up to 10 lbs. per square inch.

The dial will probably record the maximum pressure when the engine is started from "cold," but as the engine warms up in running, so the oil will become more fluid and the pressure will fall quite low—it may even record only one pound. This, however, is sufficient because if the oil is circulating that is all that is necessary.

An obstruction in the oiling system while the car is running would be indicated by a sudden rise in the pressure on the gauge. A flickering finger may indicate a serious deficiency of oil in the crankcase. Any unusual difference from normal registration should be quickly noticed and the cause of the variations ascertained and set right.

Gearbox.

In the angle formed by the floor and the raised portion which is over the gearbox, on the near side, is a movable cover secured by a screw. Unscrew and remove this cover. Immediately below it is the plug of the hole through which oil is poured into the gearbox.

The same grade of oil as is used for the engine is most suitable for the gearbox. Do not use thick gear oil, otherwise seizure of bearings may result.

Maintain the oil at the correct level, i.e., bottom of the filler plug hole.

The gearbox should be drained, and refilled to the correct level after the first 1,000 miles and every 5,000 miles subsequently. Quantity approx. $1\frac{1}{2}$ pints.

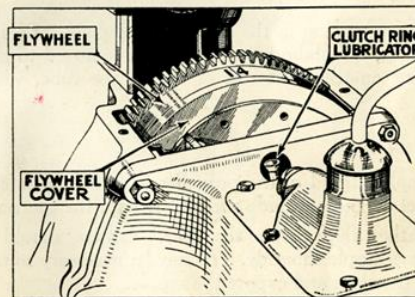

Clutch.

The clutch surfaces being of a fabric material must be kept free from oil and grease, or the clutch will fail to grip. Lubricate the operating ring lightly through the oiler, as shown on the sketch, once a week.

The oiler can be seen from the driving seat when the rubber mat has been turned back. Press the clutch pedal down a little and the oiler will move forwards to facilitate lubrication.

Steering Gear.

To obtain easy steering it is important to give regular attention as regards lubrication. The grease gun nipple is on the top of the worm case, and if a charge is given once a month it is sufficient to lubricate the bearings of the worm and worm wheel and also lubricate the worm itself.

If too much is injected at this point, it will get up the column and exude round the steering wheel. The bearing at the top of the column, just under the steering wheel can be given a little oil from the oil-can.

Steering connections on the side rod are best lubricated by means of an oil can which ejects the oil under pressure into the sockets, and the nipples at the end of the cross rod should be given a charge of grease once a week.

Rear Axle.

For the rear axle, attention every 1,000 miles should be sufficient. A special oil is used and is injected into the axle from behind and underneath, using the special adapter on the grease gun barrel. First remove the plug, then place the end of the adapter into the oiling hole, and grasping the barrel of the grease gun, push. When replacing the plug see that the washer is not omitted. The plug also serves as an oil level indicator.

Therefore do not replace the plug at once, but give time for the superfluous oil to run out, if too much lubricant has been injected. This is most important, because if the back axle is overfilled, the lubricant may leak through on to the brakes and render them ineffective.

Drain the rear axle every 5,000 miles, and replenish to the correct level.

Torque Tube.

There is a raised casing in the centre of the floor. Behind the front seats, on this casing, is a sliding panel, which is removed to give access to the greasing point on the front end of the torque tube, which requires grease monthly.

Propeller Shaft.

The front, splined end of the propeller shaft is lubricated through a hole in the tunnel on the near side and just behind the gearbox.

A small leather flap covers the hole. Grease should be applied through the grease nipple monthly. It may be necessary to move the car in order to turn the shaft and expose the nipple.

Brake Gear.

On each of the rear wheel brakes there is a self-lubricating bush for the cam spindle bearing, and there is, therefore, no greasing point on either. All other joints, etc., should be oiled once a week, including a hole on the brake pedal shaft below the steering box.

The front wheel brake cam spindle is lubricated from the swivel pin as shown at B, in the illustration on page 41.

Front Axle.

The swivel pins are lubricated with the grease gun and should receive attention once a week.

Radius Rod Anchorage.

Oil should be applied occasionally to the cups and ball flange forming the radius rod anchorage on the front cross member, just below the rear of the gearbox.

Fan.

The fan bearing requires a charge of grease once a month through the nipple on the fan bracket.

Road Springs.

The rear ends of the rear road springs where they are attached to the axles are provided with greasing nipples, and should be given a charge once a week if the car is continually used. To ensure the best results it is essential that the road springs should be lubricated. A penetrating oil should be used. It can be sprayed from the container or applied with a brush. If the rear wheels are removed the springs are fully accessible.

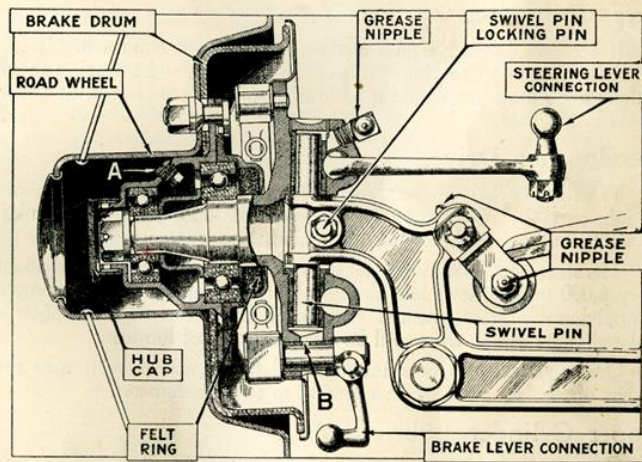

Front Hub and Nipples.

The Hubs.

Both front and rear hubs require occasional greasing.

Remove the road wheel. Turn the hub until the plug "A" is at the top. Screw out the plug and apply the adapter of the grease gun, and inject about a quarter of a gun full.

It is important that the hubs are not given too much grease otherwise it will penetrate to the brakes to render them ineffective.

Once a month, or every 1,000 miles is often enough for this attention.

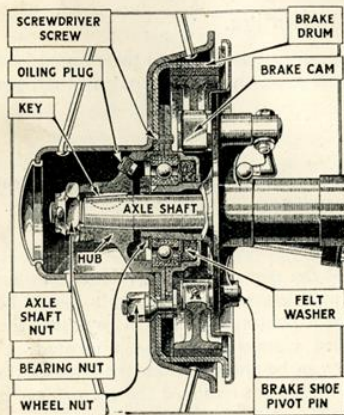

Austin
"Seven"
Rear
Hub.

Grease Nipples.

If a grease nipple becomes choked, unscrew and remove it. It can usually be cleared by soaking it in paraffin or petrol, and syringing either of these through it, but should it be found impossible to clear it, fit a new nipple in its place.

Speedometer Drive.

The flexible shaft of the speedometer drive from the gearbox should be lubricated by oiling from the speedometer end every 2,000 miles. To do this uncouple the union nut behind the speedometer.

The shafting should also be taken down and thoroughly cleaned about every 6,000 miles. It should then be lubricated along its whole length by applying thin grease, such as Vacuum H.T.3, so that when the shaft is replaced in its tubing there will be a good supply of lubricant.

Grease should also be smeared round the flange where it rubs the washer of the key piece which connects to the speedometer.

Upper Cylinder Lubrication.

Upper cylinder lubrication has been found to be beneficial to the running of the engine, either by adding the lubricant to the fuel when refilling the tank, or by fitting one of the special devices available whereby the oil is sucked into the engine via the induction pipe and mingles with the explosive charge.

Mixing with the fuel, however is quite satisfactory and saves the trouble and expense of an extra fitment.

When adding the upper cylinder lubricant to the fuel, do so according to the instructions given with the various brands.

THE GREASE GUN.

THE type of grease gun supplied in the tool kit of all Austin cars is known as the Enots "Autolub" gun, and it incorporates features by which the chassis lubrication of the car is greatly simplified.

Once the gun has been charged all that is necessary is to keep pushing the ram of the gun against the nipple until the contents are exhausted.

The ram is automatically returned to its extended position by a spring. This action creates a vacuum in the gun by means of a valve, and thus refills the high pressure chamber contained in the ram. Three or four strokes of the gun for each nipple are sufficient.

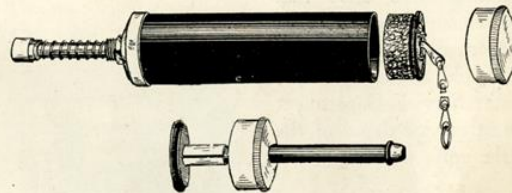

The ram is used for forcing grease through nipples, and the adaptor for lubricating the back axle with oil. For this operation, first replace the screw-on cover of the ram, then remove the end cap from the barrel of the gun, pull out the cork plunger by means of the chain, and charge the gun to about three-quarters of its capacity. Put the cap of the adaptor on the open end of the gun, and after removing the plug from the back axle, place the end of the adaptor into the greasing hole, and, grasping the barrel, push. This will inject a large quantity of lubricant quickly.

When charging the gun, it should be filled with lubricant to about three-quarters of its capacity.



AN INVITATION

AUSTIN OWNERS and others interested are invited to visit Britain's largest self-contained motor works and see how Austin Cars are made.

The normal tour of the Works occupies two hours, and appointments should be made for parties in excess of ten.

Tours commence daily, except Saturday afternoons, at 10 a.m., 11 a.m., 2 p.m. and 3 p.m.

Visitors should ask the Commissionaire for the Reception Department.

ELECTRICAL EQUIPMENT

Cleaning Commutators and Brushes ; Battery Attention

THE lighting and starting units on the Austin Seven car are arranged for wiring on the single wire system, the return path of the current being provided by the frame instead of a second wire. It is essential that all units are in good metallic contact with the frame.

Should difficulties arise that cannot be understood or remedied from the information given below, application should at once be made to the Austin Service Department or the nearest service depot of the makers of the equipment.

Dynamo.

The dynamo is a simple self-regulating third brush machine. The only parts calling for any attention are the commutator and brushes, which are readily accessible when the cover is removed.

The commutator surface must be kept clean and free from oil or brush dust. It may be cleaned with ordinary soft rag, but if it has been neglected use fine glass paper. Blow away any carbon dust, see that the carbon brushes are wearing evenly and that the arms move freely on their pivots. To fit a new brush, it is only necessary to remove the single screw to withdraw the worn brush from its holder.

The dynamo bearings are packed with grease before leaving the works and do not require oiling. When the car is overhauled, it is advisable to have the machine dismantled and the bearings repacked with grease. This work is preferably carried out by a Lucas Service Depot.

Dynamo Field Fuse.

A fuse is provided in the dynamo field circuit to protect the machine in the event of anything being wrong in the charging circuit, e.g., a loose or broken battery connection. The fuse is of the cartridge type and is housed with the half charge resistance in the cut-out and fuse unit on the engine side of the dash (see page 47).

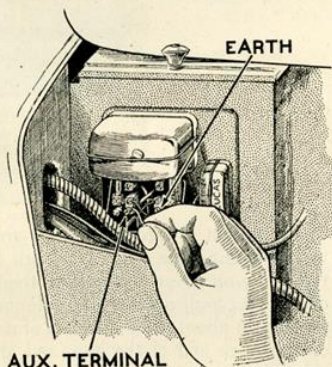

Extra accessories should be connected to the accessories and earth terminals.

If the dynamo fails to charge the battery at any time (indicated by a discharge reading being given on the ammeter during day time running) inspect the fuse and if it has blown replace it with the spare fuse provided, after inspecting the charging circuit wiring for loose or broken connections and remedying. This fuse must not be replaced while the engine is running. If the new fuse blows after starting up, the cause of the trouble must be found, and we advise that the equipment is examined by one of our Service Depots.

Never fit any fuse other than the Lucas standard fuse as originally fitted. The size of the fuse is marked on a coloured paper slip which can be seen inside the fuse.

Starting Motor.

The commutator is accessible on removing the sheet metal band cover. The unit requires very little attention beyond keeping the commutator clean and free from oil, brush dust, etc., as in the case of the dynamo. Remember that although the starter will turn the engine over, however stiff, it is advisable to crank the engine over by hand for two or three revolutions as this will considerably diminish the load for starting.

If the starter pinion jams in mesh with the flywheel ring when operating the starting motor switch, usually it can be released by putting the gear lever into top gear, and moving the car bodily backward and forward. If this plan is ineffectual the starter will have to be dismantled.

Never use the starting motor to propel the car, as it throws too severe a strain on the battery and the motor.

If the engine does not start at the first attempt, do not press the starter switch until the engine has come to rest. If this precaution is not adopted, the starter ring teeth on the flywheel, or the starter pinion teeth, may be damaged.

Switch Board.

A key is provided by means of which the ignition switch is moved so that the engine can be started. When the slot into which the key fits is in a vertical position, a spring releases the key and it may be withdrawn. The ignition is then cut off. To switch on the ignition, insert the key and turn to the right, until the slot is in a horizontal line. The key cannot be withdrawn while the ignition is switched on; it must be turned off and the slot be in a vertical position first.

The lighting and charging switch positions are:—

“Summer Half Charge.”—Dynamo giving about half its normal output.

“Winter Full Charge.”—Dynamo giving its full output.

“Side.”—Side Lamps and tail lamp on.

“Head.”—Head Lamps, side lamps, and tail lamp on.

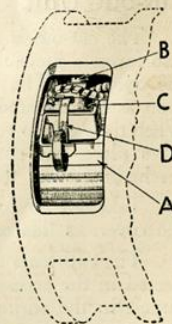

A Commutator
B Brush Securing Screw
C Brush
D Brush Spring

The dynamo automatically gives its full output when the lamps are switched on.

Dipper Switch.

The dipper switch has two positions—one to give the normal driving light, and one to dip the near side head lamp beam and at the same time switch the offside headlamp off.

If the headlights are on full, a touch of the foot on the switch alters the lights to the "dip and switch" position, and they remain so until another touch returns them to the "full on" position.

Ammeter.

The centre zero ammeter indicates the rate at which the battery is being charged or discharged under all conditions. For instance suppose 2 amperes are consumed when the side and tail lamps are switched on, and that the ignition coil takes 2 amperes, then if the dynamo is generating 7 amperes the meter will show 3 amperes on the charge side of the scale. This is the current in excess of the lamp and ignition load that is available for charging purposes.

The ammeter gives an indication that the system is functioning satisfactorily. For example if no reading is given on the charge side of the scale when the ignition and charging switch is in the "Winter Full C" position and the car is running at say 20 m.p.h. with no lights on, then a fault in the dynamo charging circuit is indicated.

To determine the output of the dynamo, switch off all the lights and add the amount of current used for ignition (about 2 amperes at normal speeds) to the reading given on the ammeter.

The amount of current used for ignition may be somewhat higher than the above figure when starting. The ammeter does not indicate the amount of current used by the starter.

Cut-out Unit.

The cut-out is mounted together with two fuses as one unit, which also forms a junction box and incorporates the half-charge resistance for the dynamo. The cut-out automatically closes the charging circuit as soon as the dynamo voltage rises sufficiently above that of the battery. When the dynamo voltage falls below that of the battery the reverse action takes place, the cut-out opens and thereby prevents the battery from discharging itself through the dynamo.

Take care not to close the cut-out contacts when removing or replacing the cover, as this may cause damage to the equipment.

The two fuses fitted are of the cartridge type. One of them is connected in the accessories circuits, and will blow in the event of a short circuit in the wiring of the electric horn, windscreen wiper, and other units connected to the "AUX" terminal, the indication that the fuse has blown being the failure of these units.

The second fuse protects the dynamo, and is connected in the dynamo field circuit. The indication of a blown dynamo fuse is that the dynamo will fail to charge, no charge reading being given on the ammeter under normal daytime running conditions.

Spare fuses are provided for use in cases of emergency. Before fitting a replacement fuse, examine the wiring of the equipment the fuse protects for loose connections or short circuits, and remedy. If the new fuse blows and the cause cannot be found, we advise the owner to have his equipment examined at a Lucas Service Depot.

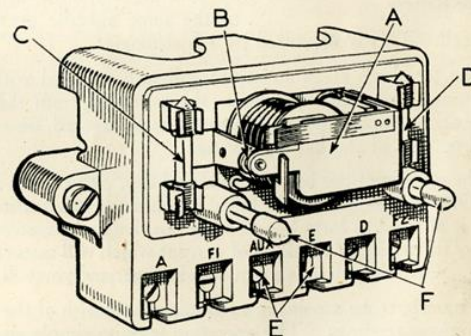

Cut Out and Fuse Unit.

- | | |
|---------------------|--------------------------|
| A—Cutout armature. | D—Dynamo field fuse. |
| B—Contacts. | E—Accessories terminals. |
| C—Accessories fuse. | F—Spare fuses. |

Never fit any fuse other than the standard Lucas fuse as originally fitted. The size of the fuse is marked on a coloured paper slip inside the fuse.

Battery.

The battery is the reservoir of the energy generated by the dynamo, and upon its satisfactory functioning depends the starting and running of the car.

The amount of attention needed is small and need take only a few minutes. Follow the directions given here and your battery will last longer and give better service.

When examining the battery, do not hold naked lights near the vent plugs as there is a possible danger of igniting the gas coming from the plates.

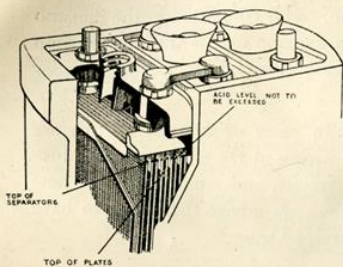

The Battery

acid in the cell. This is measured by a hydrometer.

Keep the terminals clean and tight and well smeared with vaseline. A liberal smearing of vaseline protects the terminals from the corrosive action of the acid, which, if allowed to continue unchecked, may eventually result in a breakage of the battery wiring.

Keep the outside of the battery clean and dry, particularly the tops of the cells. Dirt and moisture will form a conductor of electricity, and if such a path is allowed to form between the positive and negative terminals of the battery there will be a leakage of current which will cause the battery to run down. Give the cell tops a regular wipe over and you will avoid this.

Once a month, make a point of examining the health of the battery by taking hydrometer readings. The operation is quite simple and need not take long. There is no better way of ascertaining the state of charge of the battery.

The specific gravity readings are:—1.285 to 1.300, battery fully charged; 1.210, about half discharged and 1.150 completely discharged. These figures are given assuming the temperature of the solution is about 60 degrees F.

Do not leave the battery in a discharged condition for any length of time. If the car is to be out of use for any length of time, see that the battery is fully charged and about every fortnight give it a short re-freshing charge to prevent any tendency of permanent sulphation of the plates. In no circumstances must the electrolyte be removed from the battery and the plates allowed to dry, as certain changes take place which result in loss of capacity.

Once a month unscrew the filler caps and pour a small quantity of distilled water into each of the cells to bring the acid just level with the tops of the separators.

Distilled water can be obtained from any chemist and most garages. Do not use tap water, as it contains impurities detrimental to the battery. If any acid is accidentally spilled from the battery, it must be replaced by a dilute sulphuric acid solution of the same specific gravity as the

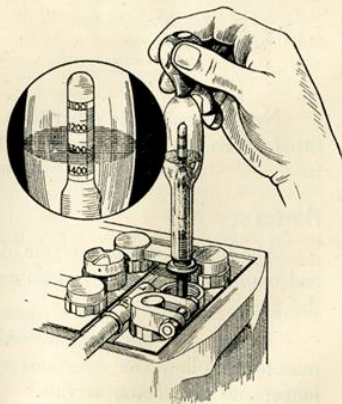

Test the specific gravity of battery electrolyte with an hydrometer.

The Electrolyte.

When the battery arrives empty (as in the case of cars sent abroad) the first thing to do is to fill and charge it.

This means that a fluid is prepared composed of one part (by volume) of pure brimstone concentrated sulphuric acid with three parts (by volume) of distilled water. Mix these in a glazed earthenware vessel. Great care must be taken in this operation. Add the acid in very small quantities, almost drop by drop, and stir with a glass rod.

Never add the water to the acid. This is highly dangerous and a serious explosion may result.

This mixing generates heat, and it is important that the electrolyte (as the mixture is called) should not be used in the battery before it has been allowed to cool. Pour the electrolyte into the cells of the battery by means of a lead, glass or celluloid funnel, until it completely fills the cells to the top of the vent hole. Allow the battery to remain in this condition for 10 minutes or so, then put in more acid solution so that each cell is again filled to the same point with electrolyte. The electrolyte will have a specific gravity of 1.285 when fully charged. Batteries should stand at least twelve hours after their first filling before charging is begun.

Of course if it is desired, the battery can be filled at almost any Service Station.

Direction Indicators.

Every two or three months raise the "Trafficator" arm and, by means of a brush or other suitable article, apply a drop of thin machine oil, such as sewing machine or typewriter oil, to the hinge between the arm and the operating mechanism.

Never pull the arm out unless both ignition and control switches are "on."

To replace a bulb, switch the "Trafficator" on and then, supporting the arm, move the switch to the off position.

Withdraw the screw on the underside of the arm and slide off the metal plate. The burnt-out bulb can then be replaced. To replace the metal plate, slide it on in an upwards direction so that the side plates engage with the slots on the underside of the spindle bearing. Finally, secure the plate by means of its fixing screw.

Bulbs fitted: Lucas No. 255, 3-watt festoon type.

If the direction indicators or electric petrol gauge fail to function, examine the fuse protecting them. This is fitted on the dash near the cut-out. If it has blown, inspect the wiring for a short circuit.

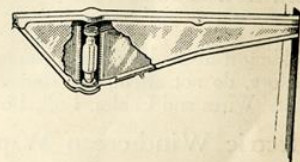

The Trafficator Bulb.

If the new fuse blows, the cause of the trouble must be found, and we advise that the equipment is examined by a Lucas Service Depot.

Petrol Gauge.

The electric petrol gauge is automatic and registers the contents of the petrol tank. It is active only when the ignition is switched on. Consequently when the tank is being replenished, first switch off the ignition to stop the engine, then switch on again and the needle on the dial will record the amount of spirit which is poured into the tank.

The gauge is very unlikely to fail, but in this eventuality, Messrs. S. Smith and Sons (M.A.), Cricklewood Works, London, N.W.2. (the makers) or their depots will give prompt service.

Electric Horn.

The horns, before being passed out of the works, are adjusted to give their best performance and will give a long period of service without any attention. No subsequent adjustment is required.

If the horn becomes uncertain in its action, giving only a choking sound, or does not vibrate, it does not follow that the horn has broken down. First ascertain that the trouble is not due to some outside source, e.g., a discharged battery, a loose connection or short circuit in the wiring of the horn, or a blown fuse.

It is also possible that the performance of a horn may be upset by the horn becoming loose on its mounting.

This can be ascertained by removing the horn from its mounting, holding it in the hand and pressing the push. If the note is still unsatisfactory, do not attempt to dismantle the horn, but return it to Messrs. Rists' Wires and Cables, Ltd., Lowestoft, for examination.

Electric Windscreen Wiper.

To start, pull out the curved handle and swing it aside so as to move the cleaning arm into position on the screen. Then pull out the switch knob and give it a spin. To stop the wiper push in the knob. Then pull out the curved handle and turn into the top of the switch knob. This locks the arm out of the line of vision of the driver and also ensures that the wiper is switched off.

The wiper requires no attention; all moving parts are packed with grease during assembly and no lubrication is required.

When cleaning the windscreen, the wiper arm can be easily lifted from the screen, but care must be taken that it is not forced from side to side.

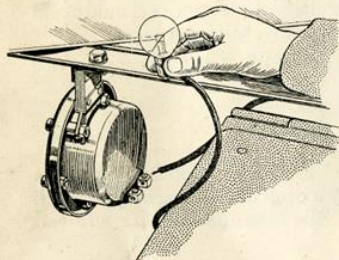

Test the horn lead with a bulb to ascertain if the wiring is faulty.

Wiring Diagram Austin "Seven"

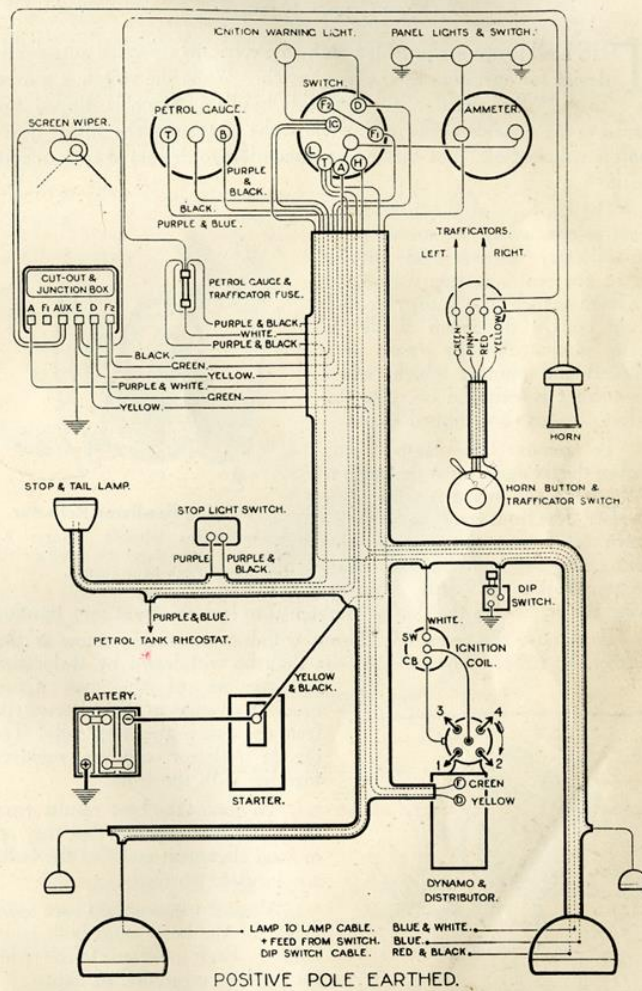

XL311

THE LAMPS

Dip and Switch Mechanism and How to Replace Fuses

THE head lamps are provided with an electrically operated anti-dazzle device for operation by the foot switch. When the switch is moved to the "dip" position, the near-side headlamp beam is dipped and turned to the nearside of the road, while at the same time, the offside headlamp is switched off, thus causing no discomfort to drivers of approaching traffic.

The dipping of the head-lamp beam is effected by a movement of the reflector. This is made in two parts; the centre portion is pivotted in a fixed rim which is in turn secured to the body. Movement of the reflector is controlled by means of a solenoid and plunger which, when the current is switched on, tilts the reflector to give the dipped beam.

To remove the lamp front, slacken the fixing screw at the bottom of the lamp and swing it aside from the slot. The front can then be withdrawn. When replacing, press the front on to the lamp body, locating the top of the rim first. Finally swing the screw into the slot and tighten it to lock the front into position.

To remove the nearside reflector, withdraw the fixing screw at the back of the lamp. The reflector can then be withdrawn by dislocating the tongues of the two fixing brackets rivetted to the reflector rim from the slots in the lamp body. The offside reflector can be removed together with the front.

To obtain the best results from the lamps it is essential that they are in good alignment and that the bulbs are focussed correctly.

Alternative positions are provided for the head lamp bulb in its holder. Each position to be tried for the best projection of light.

To align the lamps, slacken the single fixing nut, then move the

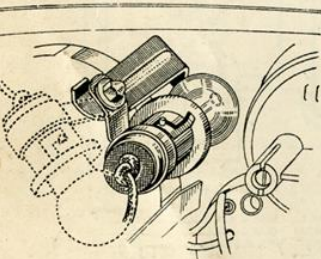

How the Instrument Lamp swivels for replacing the Bulb.

lamp on its adjustable mounting to the desired position, finally locking the adjustment by tightening the nut.

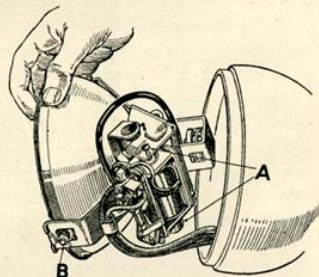

Dipping Headlamp Reflector.

By easing the solenoid plunger A, or oiling the pivots B, of the dipping reflector, fuse troubles can be overcome.

The Fuse.

A fuse is provided with the electrical dipper unit to protect the equipment in the event of the reflector failing to function properly. The fuse is of the cartridge type, and is carried in spring clips alongside the dipping mechanism. If the reflector fails to function, remove the fuse from its holder and see whether there is a break in the fuse wire. A spare fuse is clipped to the reflector bracket.

If the fuse should blow repeatedly, and the cause cannot be found, have the reflector examined at the nearest Lucas Service Depot.

Side Lamps.

The lamp front can be removed by twisting it to the left and withdrawing.

Tail Lamp.

The front of the combined stop and tail lamp can be removed for bulb replacement when the fixing screw is slackened sufficiently.

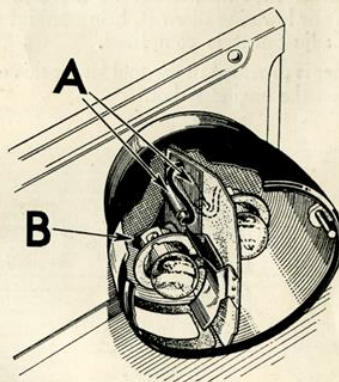

Combined Stop and Rear Lamp.

A. The Cable Sockets.
B. Bulb Contact.

Bulb Sizes.

The sizes of bulbs used are:—Head, Lucas No. 74; Side, Stop, Tail and Instrument Panel Lamps, Lucas No. 200.

Reflectors.

The reflectors of the lamps are covered with a protective coating, and any marks can be easily removed by means of a soft cloth.

On no account use any metal polish on reflectors.

RUNNING ADJUSTMENTS

Decarbonising; Valve Grinding; Brake Adjustments

THE adjustments set out below are all that the owner will find it necessary to make to keep the car in good running order.

Valve Tappet Adjustment.

To ensure that the full power of the engine is obtained and to maintain silence in the valve operation, it is essential to keep the tappets correctly adjusted. To make this adjustment, remove the valve cover, and have the engine turned slowly round with the hand starting crank.

While each valve is closed there should be between the valve stem A (illustrated) and tappet screw B a clearance equal to the thickness of the thin blade of the "tappet clearance gauge," (.004 in. with the engine hot). If the clearance is other than this, it can be adjusted by loosening the locknut C and raising or lowering screw B, being careful to tighten up the lock-nut when the adjustment is completed.

A special spanner is provided in the tool kit for this operation. Check this adjustment when the engine is hot.

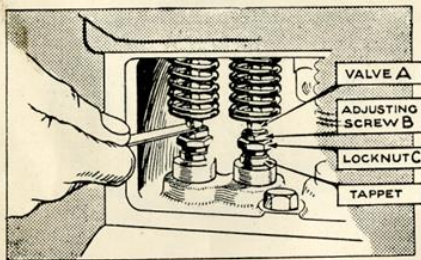

On Sports Models the most efficient setting of the tappets is that which gives a clearance of .004 in. **when the engine is very hot.** It is not easy to make the necessary adjustments when the engine is really hot—there is always the danger of burnt fingers and hands—so to compensate for the expansion due to a hot engine, the tappets should be adjusted when the engine is cold, thus:—inlet .008 in., exhaust .010 in.

Cleaning Combustion Chamber.

To secure the maximum efficiency from the engine it is necessary to remove the carbon deposit that will have formed on the surfaces of the combustion chamber. This should be done after about 2,000 miles running.

When the cylinder head is off for this job, it is advisable to take this opportunity of grinding-in the valves, although this will need a longer time for the work to be carried out. In any case, it is recommended that after about 4,000 miles the work of grinding-in the valves should be undertaken.

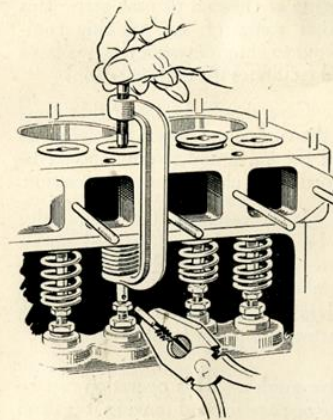

Valve Cotter Pin.

First drain the water through cock under the radiator. Detach the top water tube from the head. Disconnect the high tension wires from the sparking plugs. Remove the nuts holding down the head. Then take hold of the head at each end and lift it off.

This should be fairly easy to do, without damaging the joint washer, which, in the ordinary course, may be in a condition to be replaced.

When working at the partly dismantled engine a spanner or perhaps part of the engine may be dropped on to the "live" starter terminal, thus causing a short and possible damage. Therefore, disconnect the battery cable at the battery for safety.

Removing the Carbon.

When the head has been removed the valves and tops of pistons will be exposed to view. All dirt or deposit should be removed by carefully scraping with a sharp tool.

Before grinding-in valves it will be necessary to remove the inlet pipe, and exhaust manifold and carburetter. Then disconnect the carburetter control, and the air strangler wire. The valve cover with its washer, can be removed on undoing the two milled nuts.

Each valve spring must be lifted by means of the special tool provided to allow the cotter pin to be withdrawn. Then remove the spring. The valve is now free to be rotated on its seat when the tappet screw has been lowered clear of the stem. After the valve is cleaned a little grinding

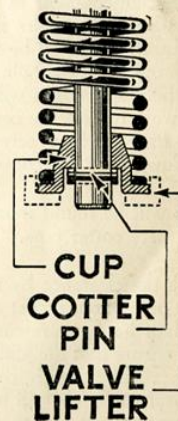

compound should be smeared evenly on its face and the valve rotated backwards and forwards by means of a screwdriver, advancing it a step at short intervals until the pitting is removed.

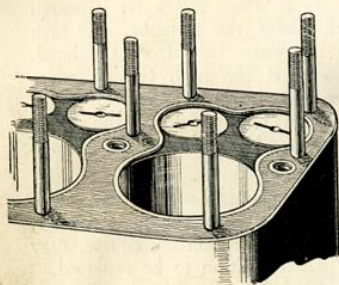

Replace the Gasket beaded edges upwards.

Lift each valve a little from its seating at the end of each step—this allows some of the grinding compound to enter between the two faces and facilitates the cutting action.

Care should be taken that none of the compound enters the cylinders and the valve and seating should be wiped quite clean after the operation.

It is essential for each valve to be ground-in and refitted on its own seating, as indicated by the number on the valvehead. The valves are numbered from 1 to 8, starting from the front.

It is also desirable to clean the valve guides. This operation can be done by dipping the valve stem in petrol or paraffin and moving it up and down, and round, in the guide until the dirt is removed. Then the valve should be cleaned, and the stem smeared with graphite grease and re-inserted in the guide, the valve spring and cup being fitted up round it. The valve lifter is then used as before to compress the spring so that the cotter pin can be refitted.

See that all the slots in the heads of the valves are in line, because this indicates that the holes in the valve stems into which the cotter pins are to be inserted will all be facing the operator. See that the cotter pin is placed properly in the hole in the valve stem, so that the cup fits evenly over it, otherwise the pin will fly out. It is easiest to fit the end valves first, and work toward the centre. The cotter pin is inserted in the valve stem, and then the lifter screw is slackened to allow the valve spring cup to come down over the cotter pin.

Pliers will be found more convenient than fingers for removing and replacing valve cotter pins.

Check the clearance by means of the tappet clearance gauge, and as a measure of caution, repeat the checking after the car has run 100 miles, as the valves have a tendency to bed down again. When refitting the manifolds ensure that the joints are good. The cylinder head joint washer should be replaced with the beaded edges upwards. A little grease smeared over each side will make a good joint and prevent sticking when the head next has to be lifted. When replacing the head take care to tighten the nuts evenly.

It is advisable to tighten the nuts in the order shown on the sketch.

Don't turn them right up at the first operation, but go over them a second time and tighten them securely and fully.

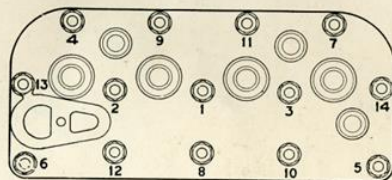

The method will ensure that the head has been evenly replaced, and the nuts on the studs uniformly and securely tightened.

Don't forget after replacing the head, to refill the radiator with water.

Lifting the Cylinder Block.

For access to the pistons (except the piston crowns), and the connecting rods, or for fitting a new tappet plunger or guide, it is necessary to lift the cylinder block. The three nuts on the distributor side are easily removed, also the three barrel nuts on the valve side can be removed without difficulty when the valve cover has been taken off. For access to the nut at the front of the cylinder block the dynamo and casing, with the fan bracket and fan, must be lifted clear. First pull the ignition leads and the lead from the coil from their sockets in the distributor cover.

Disconnect the dynamo, and remove the fan belt. The casing is secured by three set screws and a nut. With the casing removed, the front cylinder block nut is accessible. For access to the rear nut of the block, remove the inspection cover of the clutch pit from the toe plate. Then remove the flywheel housing cover, which is secured by two set-screws to the flywheel housing. Next remove the lower hose connection, and the cylinder block can be lifted.

When refitting the block it is necessary to use sleeves on the pistons to compress the rings. These piston ring sleeves are among the extra tools obtainable from the Service Department of the Austin Motor Co., Ltd.

It will be necessary to retime the ignition after re-assembling.

Adjusting the Brakes.

Both the hand brake and the foot brake operate on all four wheels. They require adjusting when the hand lever can be pulled right back to the full travel on the rack, and when the pedal can be pushed nearly to the floor-board without either brake holding the wheels.

The car should never be taken out when in this condition, but should be attended to at once.

To adjust the foot brake, under the car and approximately under the foot controls is a wing nut. This nut is reached by raising a disc in the floor just in front of the driver's seat. Pull on the hand brake to enable the wing nut to be turned easily.

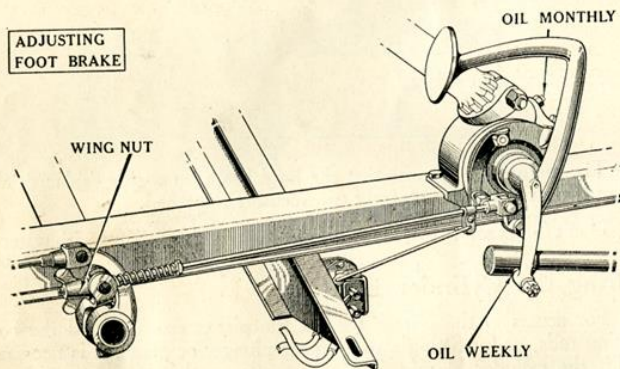

The wing nut must be screwed towards the front of the engine until the brakes go full on when the pedal is depressed about 2 in. When the pedal is up, the brake shoes should not rub the wheel drums in which they operate.

For adjusting the rear brakes, which may be necessary after re-lining the shoes, an individual adjustment for each of the rear brake cables is provided. A screwed end, to which the cable is attached, screws into the front fork-end, which secures the cable to the compensating tube lever. By removing the fork-end from the lever (a pin, secured by a split-pin, holds it) the fork can be screwed further on or off the screwed cable end to effect the adjustment.

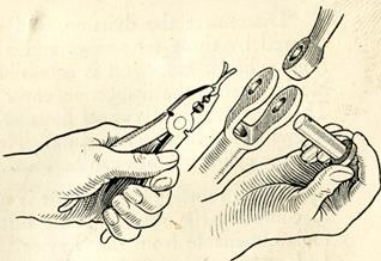

Rear Brake Connection.

The cable must not be twisted while this is being done. To test whether both brakes engage equally at the same time, jack up the back axle, and with the brake pedal pressed down, turn each wheel by hand to judge the braking effect.

Having done this the hand brake lever should be adjusted. This is done from under the car, by hand. A wing nut is provided by means of which the slack between the hand brake lever and the brake gear is taken up.

The hand brake lever must be pushed forward to its limit; that is the brake must be right off. Then turn the wing nut clockwise until the hand brake lever will only move freely one notch in the rack without moving the brake mechanism.

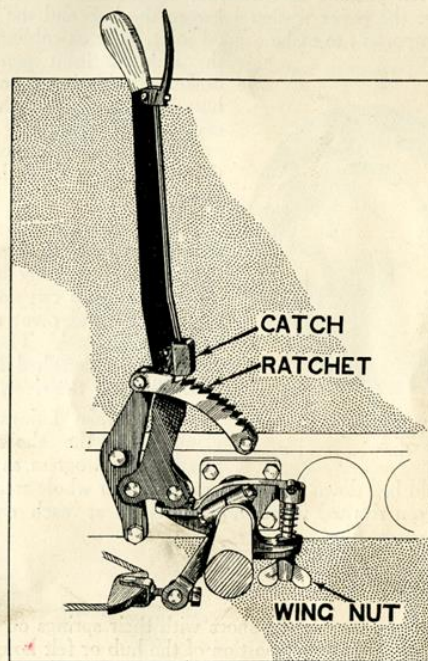

If this short movement is made without beginning to operate the brakes, it indicates that the brake shoes will not rub against the drums when the hand brake lever is in the "off" position; and that the adjustment has been properly made.

Re-lining the Brakes.

To re-line the rear brakes it is necessary to remove the wheel, and then the brake drum, by unscrewing the three screwdriver screws which secure it to the hub; and, before the shoes can be removed for re-lining, the hub and wheel bearing must be extracted.

For this a special hub extractor is supplied in the tool kit.

For the rear wheel brakes (see illustration on page 42) remove the axle shaft nut, having first taken out the split pin; and extract the outer portion of the hub by screwing the extractor on the screwed end, and

turning the extractor bolt, which bears on the end of the axle shaft. Remove the key from its keyway in the axle shaft.

Next remove the bearing nut, having first knocked back the tang of the washer locking it, and prise the inner portion of the hub or felt housing, together with felt packing and bearing, off the end of the axle casing. Do not damage the paper washer between the hub and the felt housing faces, as it is important to make a good joint on reassembling to prevent the hub lubricant penetrating the brake. If this inner portion of the hub does not come off the axle casing easily, the outer half should be refitted as closely as possible, using the wheel nuts to draw the two halves together.

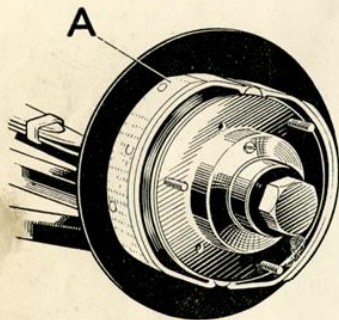

Bevel the ends at A.

Then use the hub extractor a second time, and so remove the hub together with bearing and packing. The brake shoes can now be pulled off the cam and pivot pin, and the springs unhooked. The old linings can then be detached by punching or drilling out the rivets.

The brake linings should be clamped to the shoes while the riveting is in progress, as it is essential

that they should bed down on the shoes over their whole area. When the linings have been rivetted in position, bevel off at each end for about $\frac{1}{4}$ inch with a coarse file.

Reassembling.

To reassemble, replace the shoes with their springs on the cam and pivot pin. Replace the inner portion of the hub or felt housing with the bearing and packing on the axle casing end, and push up home by tightening the bearing nut, which must be locked by the locking washer in the same way as before dismantling. Replace the paper joint washer on the felt housing face, insert the key in the shaft, push the hub over the axle shaft, on the key, and draw it up to the felt housing by the wheel nuts on their studs.

When the joint faces of the hub and the felt housing are together, replace the axle nut and tighten securely up to the hub boss. Remember to insert the split pin through the nut. Then remove the wheel nuts from the hub, fit the brake drum, and insert and tighten the three screwdriver screws.

Front Brakes.

For the front brakes (see illustration on page 41) the operation is somewhat different. Having removed the wheel, the hub cap and the axle

nut, screw on the extractor and draw off the hub complete with brake drum. The brake shoes are then clear for removal.

On reassembling remember to fit a new split pin through the axle and nut. There is a hole in the end of the hub through which the pin can be inserted.

It is always necessary to re-line all four brake shoes on the one axle at the same time, and before or after the re-lining it may be necessary to slack off the brake adjustment before the brake drum can be removed or replaced.

After re-lining the brakes, make sure that the hubs contain sufficient lubricant, and re-adjust the brakes.

Adjustment of Steering.

If after continual use slackness should be felt in the steering, two adjustments are available.

In order to take up the play in the steering column, loosen the nut which tightens the bracket supporting the steering outer column to the instrument board. Unscrew locking peg (A) and clamping bolt (B) then turn the sleeve (C), with the special spanner provided for the purpose, until the play has been removed. Do not screw the sleeve in too tight or the steering will then become stiff.

Having adjusted the sleeve correctly, screw in the locking peg so that it enters one of the slots of the sleeve and tighten the clamping bolt and the supporting bracket to the instrument board.

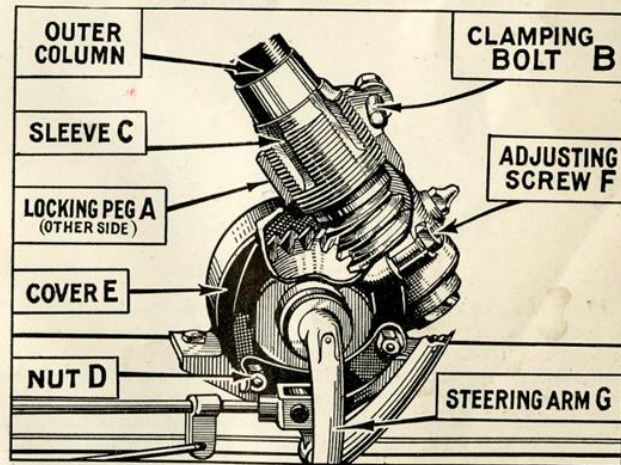

To take up the clearance between the worm and the worm wheel, due to wear, remove the locking plates and slacken the three nuts (D) holding the cover (E) to the worm casing. Then turn adjusting screw (F) so as to slightly draw the cover in the direction of the worm. Care must be taken that the worm wheel is not brought too tightly into mesh with the worm or it will make the steering exceedingly hard and stiff. Having made the adjustment be sure and tighten up the three nuts (D) and lock them with the locking plates.

Should it be desirable to remove the steering worm wheel from the casing, it is only necessary to slacken the adjusting nut (F) and remove the three nuts (D), when the cover (E) can be withdrawn with the worm wheel and steering arm. The steering column can be withdrawn by first slackening locking peg (A) and clamping bolt (B), and unscrewing the sleeve (C).

These adjustments should be made by an Austin agent.

Tracking Adjustment.

One of the causes of premature tyre wear is the front wheels being out of track.

The wheels, if they are correctly tracking, should not be parallel, but should be $\frac{1}{8}$ in. closer between the rims in front of the axle than they are behind. This difference, or "toe-in" as it is called, allows for working clearances of the steering connections and any slight spring of the parts, so that when the car is running the wheels are as near parallel as possible.

If this difference is greater or smaller than $\frac{1}{8}$ in. the tracking should be adjusted. This is not difficult to effect. It is necessary to remove the cross tube lever, on the near side, from the swivel axle.

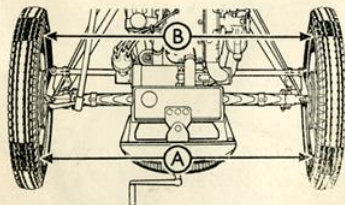

Front wheels should "toe-in." A is shorter than B.

It is secured by a nut on the front of the swivel axle, under which there is a spring washer. With this done, the steering cross tube is freed at the near side for the adjustment. On the clamping bolt of the steering arm jaw being slackened, the jaw can be screwed further on, or off, the cross tube, for so many complete turns as may be necessary. This move-

ment will enable the correct adjustment to be attained. Then the clamping bolt is re-tightened. On refitting the cross tube lever to the axle, tighten the nut securely, with the spring washer under it.

This adjustment should be made by an Austin agent who is properly equipped for the work.

Front Shock Absorbers.

The shock absorber is set to a certain initial tension before it leaves the factory, and no change in this adjustment should be necessary for a very considerable time.

Re-adjustment may only become necessary after several thousand miles of car travel, and should be made only when the spring movement seems too free. It should be noted that, normally, the full benefit of the shock absorbers will not be felt when the car is travelling at low speeds, as under these conditions the spring movement is very limited, but, as the speed increases their effect becomes more pronounced, especially over bad roads when the spring action is most severe. Testing should, therefore, be carried out at comparatively high average touring speeds and adjustment made to suit these conditions.

The frictional resistance required to effectively control the action of the springs is comparatively small, and care should be taken not to alter the pressure, when adjusting, more than is absolutely necessary in order to obtain the desired results.

For fast sporting cars and for road and track racing, a considerable increase in pressure may, of course, be required.

When adjustment does become necessary, carefully note the riding qualities of the car, and if the spring action seems too retarded or stiff, reduce the frictional resistance of the shock absorbers by turning the centre adjusting nut to the left, or counter-clockwise, after slackening the lock-nut. If the spring action seems too free, increase the frictional resistance by turning the adjusting nut to the right, or clockwise. After adjusting, tighten the lock-nut.

Careful adjustment in this manner will produce an ideal condition. The springs will have the required amount of flexibility for easy riding, but spring vibration will be reduced to a minimum and violent rebound effectively eliminated.

The rear Austin shock absorbers do not require adjustment.

Cleaning the Shock Absorbers.

Periodically—especially in wet weather when much mud is thrown on to them—the large end of the shock absorbers should be taken apart, by withdrawing the centre bolt, and thoroughly cleansed. The centre pin and washers should then be slightly smeared with grease.

If this precaution is not adopted, the shock absorbers are liable to become tight—when an excessive load is thrown on the pins and bushes at the end of the arms, which will cause rapid wear. In addition, great strain is imposed on the bracket holding the shock absorber to the frame.

Clutch Wear Take-up.

After the clutch has been in use for some time the wear of the friction surfaces will give rise to a need for adjustment in order to ensure the continued full engagement of the clutch.

The adjustment should be such as to allow at least $\frac{3}{8}$ in. free movement of the clutch pedal with one finger. After depressing the pedal to this extent the stronger resistance of the clutch springs will be obvious, so that it is easy to ascertain that the amount of free movement is correct. Lack of this free movement is serious, and does not permit the clutch to engage fully. It is of the utmost importance to maintain this free movement of the clutch pedal, and it should be inspected from time to time. Otherwise damage may be done to the clutch owing to the slipping of the plates.

The adjustment is obtained by **slightly** slackening the clamping screw at the bottom of the clutch pedal lever and depressing the pedal sufficiently to give the required free movement. The clamping screw must now be securely tightened and the adjustment checked.

Clutch Slip.

Some drivers are inclined to use the clutch instead of changing down to a lower gear, particularly when they are almost at the top of a hill and it is only necessary to change down for a few yards. Foot pressure is applied to the clutch to create a certain amount of slip (see page 11). This is a bad habit. It highly polishes the frictional surfaces and will eventually be the cause of persistent slip, finally, in addition to burning out the fabric rings, probably also distorting the centre plate and making renewal of this essential.

Sometimes clutch slip is due to oil penetrating to the clutch as a result of overfilling the gearbox. If the inspection plate over the clutch casing is removed petrol can be syringed on the clutch plate to wash off the oil so that the clutch regains its frictional characteristics.

When injecting the petrol have the engine turned so that the plate is properly washed and the petrol and oil are given an opportunity to drain away. Also push the clutch out and let it in by the pedal so that the petrol is given a washing action. Do not replace the inspection plate until the oil and petrol have had sufficient time to evaporate, or be drawn off through a hole in the casing under the flywheel. See that this hole is clear.

After this operation it is advisable to lubricate the declutching levers at their pivoting points and the clutch withdrawal collar (page 39) as the lubricant in these members may have been removed by the petrol.

Fan Adjustment.

Release the clamping pin nut on the fan bracket and then turn the spindle, which is in the form of a crank, until the necessary tension is obtained in the fan belt.

CARE OF THE BODYWORK

Air Cushions ; Cabriolet Roof ; Tourer Hood

FOR the car to look well and keep its beauty and smart appearance, the body must be given its share of attention ; it must not be neglected.

The cellulose finish of the car is easily cleaned and polished. In summer weather when the car is only dusty the dust can be lightly flicked off without water and there is no risk of damaging the finish. When the car is muddy, wash off well with clean running water—**wash** the mud off—don't rub it off. Remove any grease or tar splashes with petrol. Don't use the same sponge and cleaning

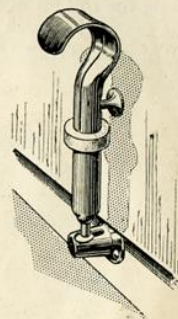

The rubber ring stops rattles.

cloths for the chassis and springs and other greasy parts as are used for the coachwork.

Polishing.

Dry off and then polish with one of the special polishes now marketed. Such preparations impart a brilliant surface and preserve and beautify the body. On no account should metal polishes be used, as are sometimes advertised for cellulose. It has been found that the more the surface of the cellulose finish is rubbed by the polishing cloth, the smoother and more lasting is the lustre imparted.



Oil door hinges occasionally.

Door locks, hinges, and other small working parts should be given a drop or two of oil occasionally.

Storing the Car.

Should the car be laid up in the garage for long periods, the fuel and water should be drained off and the batteries removed, and weight taken off the tyres.

The Cabriolet Roof.

To lower the roof on the Austin Seven Pearl Cabriolet, the following procedure should be adopted: Release the two fastenings above the windscreen (one is shown at A in Fig. 1) and lift the canopy rod. Then detach the three clips which secure the front bar on which the fabric is carried. Roll back the fabric as far as it will go, turning the material over and securing the roll (as in Fig. 2) by fastening the loop provided at each side to the top stud of each roof stretcher (as at B). Pull the two arms (C and D) of each roof stretcher in the direction of the arrows to break the

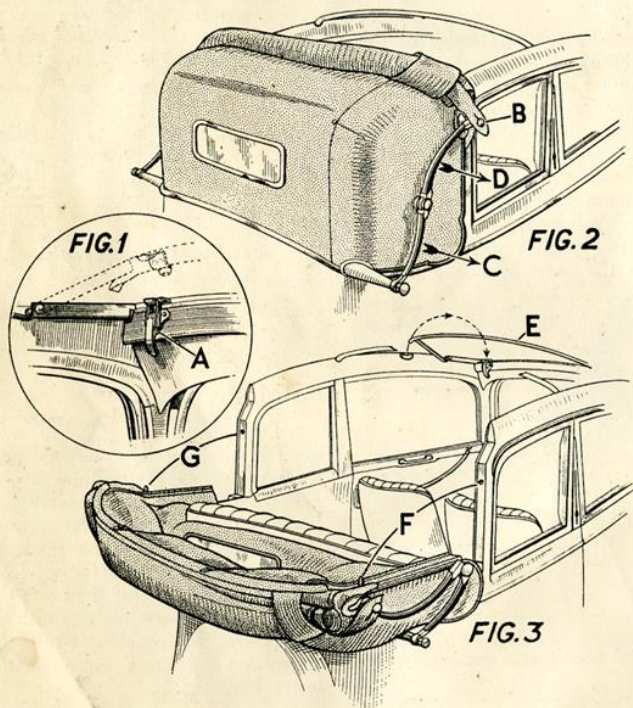

The Cabriolet Hood.

The first operation (Fig. 1) in lowering the Seven Cabriolet hood is to release the front hinged member from the front of the body by releasing Clip A. Then the head fabric can be rolled back and fastened as shown at B in Fig. 2. Next the stretcher joint is broken by pulling in the direction of the arrows C and D, and when the head is down the bar E in Fig. 3 can be swung forward. F and G are the dowels and holes which must locate when the head is re-erected.

joint and fold the rear portion of the hood down (Fig. 3). Then swing forward the hinged roof-bar (E), and secure the rear window by its two fasteners to the top of the folded roof member. It should be noted that the roof stretcher joints must not be broken before the front of the roof fabric is released from the canopy rod. Raising the roof is a reversal of the above operations. In lifting the roof members to the door pillars ensure that the locating dowel enters the hole in each pillar (as at F and G in Fig. 3).

This roof can be left rolled back at the partially open position shown in Fig. 2 if desired, but it should not be fully or partially lowered while wet.

Float-on-Air Seat Interiors.

The essence of comfort with "Moseley Float-on-Air" upholstery is low pressure—to blow up the cushions at all hard is to destroy their powers of absorbing vibration. The seat should be quite soft to the touch, the hand pressed on the surface sinking well in.

If the seats do not give perfect results release air from the valve, as the usual fault is over inflation. The butt ended portion running round the sides and front of each interior is separately inflated and should be moderately well blown up. The centre portion of each interior is also separately inflated, and the pressure should be such that the base of the seat can be felt when pressed with the closed fist. This gives the ideal pressure and support when sat upon.

To adjust the air pressure open the flap at the rear of the cushion, exposing the valves. The valve at the side inflates the "butt ended portion" above referred to; the other valve (or valves in the rear cushion) inflates the centre section. Draw gently on the tabs till the rubber valve protrudes about one inch, do not pull hard otherwise the valve may be damaged. Roll back the rubber ring towards the cushion when the plug can be readily removed from the tube. Blow with the mouth or release air as required.

Moisten plug and reinsert as far as it will go, roll ring back until it engages in the depression caused by slot in plug. Push back the valve till the cap is flush with the surface and refasten the flap.



Touring Car Hood.

In order to lower the hood of the Tourer, disconnect the four press-studs on either side, holding the hood to the side-screens, and unfasten the two knobs at the top of the windscreen.

Standing at the right of the car, lift the hood with the right hand and break the frame at the centre with the left hand. Fold right back on to the rubber stops and pull out the hood material to hang in one fold. Turn the valences under the hood sticks. Secure the hood frame by means of the two leather straps on the side of the body, roll up the hood and tuck in the ends.

The cover should be pulled on evenly, with the two fasteners uppermost. Connect the straps on the back rail of the body to the fasteners on the cover. The straps at the end of the cover are to secure the cover to the hood frame.

Before raising the hood, undo all the straps and pull out the hood material. Lift the front rail upwards and forwards and straighten the frame. Secure the fasteners at the windscreen and fasten the press studs.

Side Screens.

There are two leather loops on the side of the body towards the rear to hold the pegs of the side-screens if folded back in half. Release the front peg and lift the front half of the screen to turn it.

The rear half of front screens may be folded forward and secured by a fastener.

The side-screens can be carried in the front doors. To remove them from the body slacken the setscrews with a coin or a screwdriver and lift them.

Unbutton the flaps in the doors and insert the pegs of the screens into the holes in the bottom door rail. Two screens go into each door, with the hanging cloth and felt between them to prevent rattles.



TOOLS AND ACCESSORIES

The tools are supplied in a sealed cardboard box and the owner should see the seals are intact when the car is delivered.

The tools should be carefully checked against the list below, then put into their places in the wraps, and stowed away in the car.

$\frac{1}{4}$ in. and $\frac{3}{16}$ in. box spanner.	1 Extra ignition key.
$\frac{5}{16}$ in. and $\frac{3}{8}$ in. box spanner.	Spanner for monobloc nuts.
$\frac{3}{8}$ in. and $\frac{7}{16}$ in. box spanner.	Tool wrap.
Tommy Bar.	Sparking-plug spanner.
$\frac{3}{16}$ in. and $\frac{1}{4}$ in. double open-end spanner.	Brace for detachable wheels.
$\frac{5}{16}$ in. and $\frac{3}{8}$ in. double open-end spanner.	Tyre lever.
$\frac{7}{16}$ in. and $\frac{1}{2}$ in. double open-end spanner.	Tyre pump.
Adjustable spanner, 4 in.	Lifting jack, with handle.
Hub-cap and steering column sleeve spanner.	Screwdriver.
Distributor Screwdriver and Gauge.	Sparking plug and tappet clearance gauge.
Tappet adjusting spanner.	Grease gun with adaptor.
2 Radiator hose clips.	Valve-spring lifter.
	Combination pliers.
	Hub extractor and screw.

A spare cylinder-head joint washer is also supplied.

Extra with sports model: Valve grinding tool.



AUSTIN SPARE PARTS

All Austin Dealers carry stocks of genuine Austin replacements, and applications for spare parts should be made to them. Clients will then be certain that the replacements are made by parts manufactured by The Austin Motor Company and carrying their high reputation for quality and workmanship.

EQUIPMENT

THE AUSTIN MOTOR CO., LTD., accept no liability under the terms of their Warranty for Tyres, Speedometers, or the Electrical Equipment, or other Goods, including Coachwork, not of their own manufacture.

All claims relating to any of these parts or fittings or orders for repairs to them should be addressed to their manufacturers.

For our clients' convenience, we give below the names and addresses of the manufacturers or suppliers of the goods in question. Further information may be obtained on application to them.

IMPORTANT.—When claims under guarantee are being made, it is absolutely necessary to quote the type and number of car, and also the commissioning date.

ELECTRICAL.

(Also Mirrors)	Dynamos	} Joseph Lucas, Ltd., Great Hampton Street, Birmingham 18. Dordrecht Road, Acton Vale, London, W.3. and Branches.
"LUCAS"	Starters	
"C.A.V."	Cutouts	
	Switchboards	
	Lamps	
	Batteries	
	Windscreen wipers	

GREASE GUNS AND OIL INJECTORS.

"ENOTS"	Benton and Stone, Ltd., Bracebridge Street, Birmingham.
---------	---

INSTRUMENTS.

"SMITH"	Speedometers	} S. Smith and Sons (M.A.), Ltd., Cricklewood Works, London, N.W.2.
	Petrol Gauges	

LIFTING JACKS

	R. T. Shelley, Aston Brook St., Birmingham.
--	---

TYRES AND TUBES.

"DUNLOP"	Dunlop Rubber Co., Ltd., Fort Dunlop, Birmingham.
----------	---

CARBURETTERS.

"ZENITH"	Zenith Carburetter Co., Ltd., Honeypot Lane, Stanmore, Middlesex.
----------	---

PETROL PUMP

	"A.C." Sphinx Sparking Plug Co., Ltd., Dunstable, Beds.
--	---

DRIVING MIRRORS.

Interior and Exterior	Desmo, Ltd., 31, Stafford St., Birmingham.
Interior only	Pennant Manufacturing Co., 350, Reddings Lane, Acocks Green, Birmingham.
Also	Joseph Lucas, Ltd. (some models).

OIL GAUGES

	David Harcourt, Ltd., Theodore Street, Birmingham, 19.
--	--

HORNS.

"RIST"	Rists' Wires and Cables, Ltd., Lowestoft.
--------	---

LUCAS SERVICE DEPOTS

	Telephone.	Telegrams.
BELFAST. 3-5, Calvin Street, Mount Pottinger	57291	Servdep
BIRMINGHAM, 18. Great Hampton Street	Central 8401	Lucas
BRIGHTON, 4. Old Shoreham Road, Hove	Hove 1146	Luserv, Brighton
BRISTOL. 345, Bath Road	76001	Kingly
CARDIFF. 54a, Penarth Road	4603	Lucas
COVENTRY. Priory Street	3068	Lucas
DUBLIN. Portland Street North, North Circular Road	Drumcondra 434	Luserv
EDINBURGH, 11. 60, Stevenson Road, Gorgie	62921	Luserv
GLASGOW. Corner of Grant St. and St. George's Road	Douglas 3075	Lucas
LEEDS. 64, Roseville Road	28591	Luserdep
LIVERPOOL, 13. 450-456, Edge Lane	Old Swan 1408	Luserv
LONDON. Dordrecht Road, Acton Vale, W.3	Shepherds Bush 3160	Dynomagna, Ealux, London.
759, High Road, Leyton, E.10	Leytonstone 3361	Luserdep, Leystone, London.
155, Merton Road, Wandsworth, S.W.18	Putney 5131	Luserv, Pot., London.
MANCHESTER. Talbot Road, Stretford	Longford 1101	Lucas, Stretford
NEWCASTLE-ON-TYNE, 2. 64-66, St. Mary's Place	25571	Motolite

AUSTIN MOTOR CO., LTD. LONGBRIDGE, BIRMINGHAM.

G.P.O. Box 41.
Telephone: Priory 2101 (20 lines).
Cables: "Speedily, Birmingham, England."

Telegrams: "Speedily, Northfield.
Code: Bentley's."

LONDON:

Telephone, Mayfair 7620 (18 lines).
Telegrams: "Austinette, Telex, London."

Holland Park Hall, W.11.

Telephone, Park 8001 (9 lines).

25, North Row, Oxford Street, W.1. (Seven h.p. Repairs).

Telephone, Mayfair 6271 (7 lines).

The Austin Magazine

contains many useful hints designed to help the owner driver to perform "those little attentions that mean so much" toward getting the best from his car.

Also there are detailed descriptions of the bigger jobs that can be safely tackled at home, explained in simple language and suitably illustrated.

There are special features, interesting stories by popular authors, travel and sports articles "and motoring miscellanea."

**Your Newsagent will deliver the Magazine to
you for 4d. per month.**

