

HANDBOOK  
OF

*The Austin  
Seven*



PUBLICATION No. 1316

PRICE ONE SHILLING.

THE  
AUSTIN MOTOR CO. LTD.  
LONGBRIDGE :: BIRMINGHAM

2003 1439

*[Faint handwritten text]*

M.W. CONWAY

6 HILLSIDE CRESCENT ~~THE OLD VICARAGE~~  
PAULSGROVE ~~208, CASTLE ST~~  
PORTSMOUTH HANTS. ~~PERCHESTER~~  
~~HANTS.~~

# HANDBOOK

OF MILEAGE, 29-9-52  
66393

# The Austin Seven

£5  
Sep '83

PRICE - ONE SHILLING  
31st EDITION.

**THE AUSTIN MOTOR CO. LTD.**  
**LONGBRIDGE - BIRMINGHAM**

Telephones : - - - - - PRIORY 2101-2120  
Telegrams : "SPEEDILY, NORTHFIELD." Code : BENTLEY'S

LONDON SHOWROOMS :  
**479-483, Oxford Street, W.1.**  
Telephone : MAYFAIR 7620 to 7637. Telegrams : "AUSTINETTE, TELEX, LONDON."  
AND

**HOLLAND PARK HALL**  
**HOLLAND PARK AVENUE, W.11**

Repair and Service Depot for 7 h.p. :  
**25, NORTH ROW, LONDON, W.1.**  
Telephone : MAYFAIR 6271.

In reference to this Book  
please quote the number. **1316**

PRINTED IN ENGLAND.



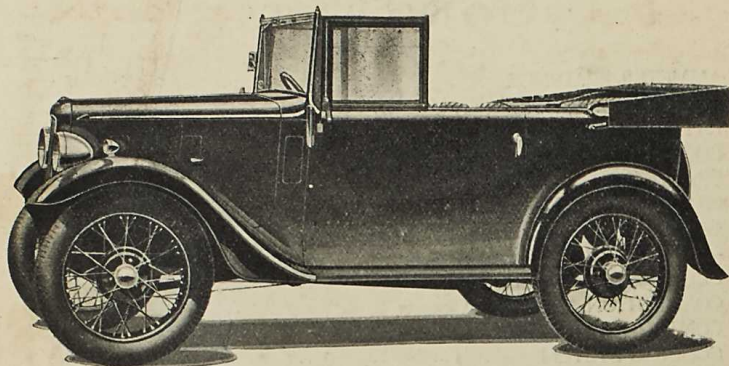

The Austin Seven Tourer.

## The AUSTIN SEVEN

**T**HE Austin Seven is acknowledged to be the best small car in the world.

It is designed for, and will carry in comfort, four adults up to a weight of 40 stones.

There are six models made, the Cabriolet, the de luxe Saloon, the Saloon with fixed head, the Tourer, the Two-Seater and a Sports Two-Seater. The closed models are alike in general lines and general equipment. Particularly good features are the wide doors with one-piece windows, which are mechanically raised or lowered. The large single panel windscreen, that can be opened wide, and secured by an ingenious lever fastening, easily reached from the driver's seat, is another advantage. The Tourer, with its easily operated hood, and side curtains that open with the doors, provides complete protection in even the most inclement weather.

Both front seats are separately adjustable, they tilt forward and allow ready access to the rear seats or luggage space.

The Sports model is a low compact fast car. Its name accurately describes the "Two-seater."

It has a 4-cylinder, water-cooled engine, synchromesh gears, and bevel drive through the differential. Lubrication is by pump, and cooling is on the thermo-syphon system and by fan.

The complete equipment includes electric hand starting and lighting switches, foot operated "dip and switch" for headlamps, air strangler, electric horn, speedometer, electric windscreen wiper, direction indicators, license holder, shock absorbers, spare wheel and tyre and blank number plates. All fittings are chromium plated, except the wheel centres which are of stainless steel.

The hand lever and pedal each apply brakes to all four wheels.

The Austin Seven is particularly suitable for the woman driver. It requires little physical effort to drive and control, and for that reason its use enables her to do shopping calls without fatigue, visit her friends, attend social and other functions, or make excursions or trips in any direction in any weather. For the same reasons business men find it an excellent vehicle, and commercial travellers and others whose occupation compels frequent calls over an extended area, have in the little car an embodiment of all they require. Calls can be made in places where trains, trams and buses are infrequent.

In large establishments where the instant use of a car is of vital importance in cases of emergency, such as sudden illness or accident, the Seven has been installed as a "tender," and in addition to its superiority over large unwieldy cars for short runs, has proved a real time and money saver.

As 40 miles per gallon is the average petrol consumption, the cost of transit is below the cost of fares on any public conveyance, and in this particular the Austin Seven has no rival.

Its speed, economy, reliability and road-holding qualities have been admitted beyond dispute.

Thousands of motorists have had their first experiences on a "Seven," thousands more will follow them.

Having successfully passed through thirteen years of severe use and trial, it has emerged a really successful and popular favourite; and its splendid qualities are internationally recognized.

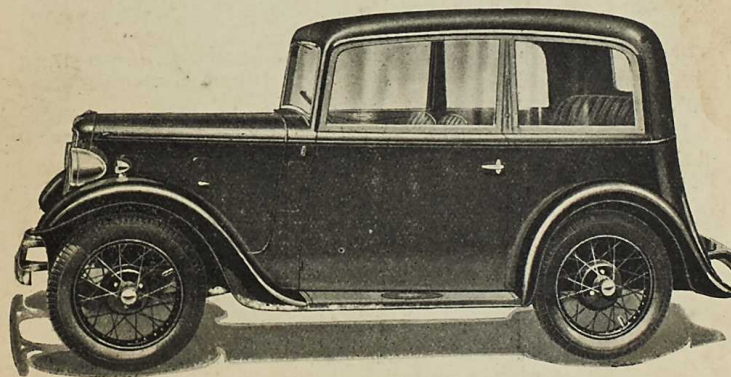

The Austin Seven de luxe Saloon.

## ITS LEADING FEATURES

- DIMENSIONS** . . . The dimensions of the models vary. Maximum length 10ft. 7 in. (3,26 mm.); Width 4 ft. 4 in. (1,320 mm.); Height 5 ft. 3 in. (1,600 mm.); Wheelbase 6 ft. 9 in. (2,057 mm.); Track, front 3ft. 4 in. (1,016 mm.), rear 3 ft. 7in. (1,092 mm.) Ground clearance (high frame) 7 $\frac{3}{4}$  in. (196 mm.), low frame 6 $\frac{3}{8}$  in. (171 mm.).
- ENGINE** . . . Four-cylinder, water-cooled, detachable head.  
Bore, 2.2 in. (56 mm.) } 747.5 c.c., R.A.C. rating, 7.8 h.p.  
Stroke, 3 in. (76 mm.) }  
Brake horse-power: 13.5 at 3000 r.p.m.  
Ignition: Coil.  
Oil circulation: by pump.  
Cooling: Thermo-syphon with film radiator and fan.  
Crankshaft bearings: Front, ball; Rear, roller.
- STARTER** . . . Electrical.
- CLUTCH** . . . Single-plate.
- GEARBOX** . . . Four speeds forward, and a reverse; The top, third and second gears have synchromesh engagement, which ensures smooth, noiseless, certain gear changes to suit varying speeds. First gear is a low one to be used in starting with a full load, up an incline, or manoeuvring the car in an awkward place. The ratios of engine to road wheels: are top, 5.25 to 1; third, 8.73 to 1; second, 13.85 to 1, and first, 22.94 to 1. Ball bearings throughout.
- REAR AXLE** . . .  $\frac{1}{2}$ -floating, with differential and torque tube.  
Ball bearings and thrusts throughout. Final drive by shaft and spiral bevel.
- SPRINGS** . . .  $\frac{1}{2}$ -elliptic cross spring in front.  
Quarter elliptics at rear.  
Shock absorbers are fitted to front and rear.
- STEERING** . . . Worm and wheel, having provision for taking up wear.
- FRONT AXLE** . . . Forged, I section.
- BRAKES** . . . On all four wheels: easily adjustable. Both hand and foot brakes operate on all four wheels.
- WHEELS** . . . Special wire detachable. One spare wheel with tyre. 4.00—17, Sports, 3.50—19 Dunlop tyres. 4.00—18 on export cars.
- CONTROLS** . . . Ball change speed gear lever, and brake lever, mounted centrally  
Foot control for dip and switch headlights. Foot accelerator is also provided.
- PETROL TANK** . . . 5 gallon tank at rear. Fuel supply by petrol pump.
- LIGHTING** . . . By gear-driven dynamo, with accumulators.
- BODYWORK** . . . Two bucket seats for driver and passenger, both being hinged to allow easy entrance to the rear seat. Rear seat to carry two adults or three children. Ample tool accommodation. Spare wheel and tyre. On touring model, hood, single piece screen and full side screens (those over the doors open with them). Electric horn, and speedometer, direction indicators, automatic windscreen wiper, driving mirror and license holder.

**WORKMANSHIP AND MATERIALS** . . . Austin quality.

## The NEW CAR

**IF YOU ARE NOT FAMILIAR WITH AUSTIN CARS PLEASE READ THIS HANDBOOK CAREFULLY.**

**G**IVE the new car a general examination to see that all is in order. Check the tool kit as list on page 69.

Before running, see the car is supplied with fuel and water, that the engine and gearbox have the necessary quantities of oil, that the battery contains the proper amount of acid—see sections Lubrication and Electrical Equipment.

Cars delivered by road are ready for running; on those transported by rail or overseas the engine may have become stiff through the gumming of oil on the pistons. A little petrol injected into the cylinders will free them. Remove the sparking plugs, pour in a thimbleful of petrol, wait a minute, replace the plugs and turn the engine over a few times by means of the starting handle.

There is no oil, fuel or water in cars crated for overseas and the batteries are empty and uncharged.

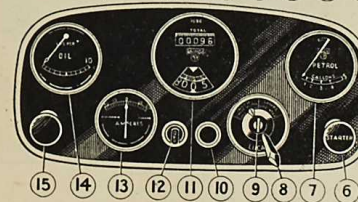
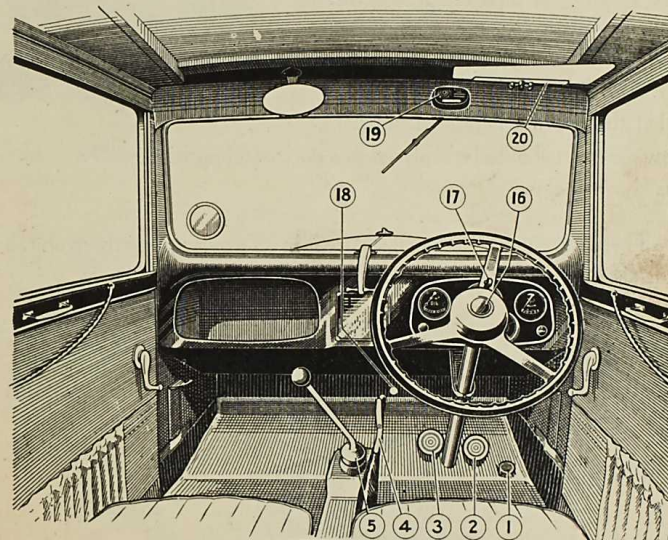

The Instrument Board (or Dash Board)

- |                            |                        |                                |
|----------------------------|------------------------|--------------------------------|
| 1. Accelerator Pedal       | 8. Switchboard         | 15. Strangler                  |
| 2. Brake Pedal             | 9. Ignition Key        | 16. Horn Button                |
| 3. Clutch Pedal            | 10. Warning Light      | 17. Direction Indicator Switch |
| 4. Handbrake Lever         | 11. Speedometer        | 18. Dip and Switch Control     |
| 5. Change Speed Lever      | 12. Dash Lamp          | 19. Windscreen Wiper Switch    |
| 6. Pull Out Starter Switch | 13. Ammeter            | 20. Visor                      |
| 7. Petrol Gauge            | 14. Oil Pressure Gauge |                                |

## Starting the Engine

Make sure that the change speed lever is in neutral position and the hand brake on.

Give the engine a few turns with the starting handle to make sure that the crankshaft is free (pushing the handle in to engage fully with the starting nut, before turning it). The ignition key is turned to the right to switch on the ignition and the charging and lighting switch is turned to "Summer  $\frac{1}{2}$  Charge" or "Winter Full C." Pull out the air shutter knob on the instrument board to close the carburetter air inlet, and pull out the switch to operate the starter. **Be sure to release the air shutter wire after the engine has started.** Do not allow the engine to race when first starting up, as time must be allowed for the oil to circulate and lubricate various bearings.

When the engine is running, see that the starting handle is not hanging down. It should be replaced in a horizontal position at "9 o'clock" as shown below.

There is a catch which will secure it in its proper place there on the off-side of the car.

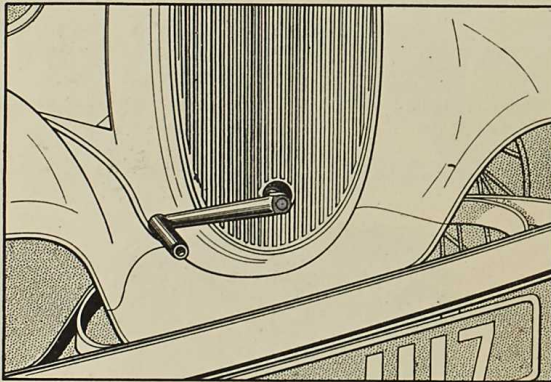

Never leave the ignition switch on for any lengthy period while the engine is not running. The warning lamp on the switch board will remind you of this.

## Difficulty in Starting

Difficulty in starting may be caused either through sucking too much petrol into the cylinders, or too little. When starting with the throttle all but closed, a strong suction takes effect on the pilot jet. If petrol is passing through the carburetter the suction can generally be heard. If the engine fails to start and there is a good deal of petrol overflowing from the carburetter it is almost certain that the mixture getting into the cylinder is too rich. The throttle should then be opened half-way to reduce the suction. On firing, the engine will race away, and the throttle should be almost closed. If the engine does not fire close the throttle entirely, and try again. After a stop in hot weather, failure of the engine to start is more likely to be due to a too rich mixture than one too lean, and one should stop the engine by the switch only after quite closing the throttle. Re-start the engine with the throttle closed.

If the starter does not turn the engine over readily, depress the clutch pedal before switching on. This will lessen the starting load, and so help the starter to turn the engine at higher speed.

If the car has been standing for a considerable time, starting may be assisted by using the hand priming lever on the petrol pump to give the carburetter a full supply of petrol.

If after the foregoing measures have been carried out the engine fails to start, the reason will probably be due to faulty ignition or carburation.

**IGNITION:** First examine the wires and see that the sparking plugs are connected. Then test the gap of the plug points by means of the thick end of the gauge provided in the tool kit. If the points are dirty, clean them before replacing the plug.

**CARBURATION:** The slow running jet may be stopped up or a main jet choked. Blow them out with a tyre pump, never attempt to clean them by passing a wire or other small metal object through them. This will definitely injure the jets.

**The engine should never be allowed to run at high speeds for the first 300 miles.**



# CONTROL OF THE CAR

THE driving seat of the Austin Seven is adjustable for position and this convenience should be taken advantage of so as to obtain the greatest comfort.

## Changing Speeds.

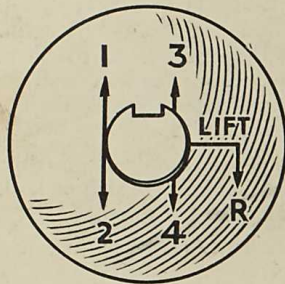

To engage first gear, push out the clutch and move the gear lever into the first speed position.

Sometimes it may happen that when the clutch is let in again, there is no apparent drive from the engine. That is because there has been no proper engagement of the gears. Therefore, push out the clutch again, and it will almost certainly be found that the lever can then be moved so as to give the proper gear engagement without using any force.

Start on first speed, accelerate to about 8 m.p.h., push out the clutch, move the lever to neutral, and continue the movement of the lever steadily to the second speed position and let in the clutch gently.

In moving from second to third speed, a similar action takes place. Accelerate to about 18 m.p.h., declutch, release the accelerator, move the lever to neutral and continue the movement of the lever steadily into the third speed position.

To move from third to top, declutch, and move the lever steadily into the position desired. It assists the change from top to third, and third to second if the accelerator is held down while the change is made.

Always change gear early on a hill; never allow the engine to labour in any gear and expect it to pick up speed on changing into a lower one when the car has nearly stopped. Do not persist in attempting to drive the car uphill in top gear when the speed falls below 18 m.p.h.—change down. If the car has been driven back by the reverse gear, wait until it is stationary before engaging a forward speed. Do not engage the reverse gear when the car is travelling forward. Serious damage to the gears will be the result.

Keep the foot off the clutch pedal except in heavy traffic. Even then, do not allow the weight of the foot to be taken by the pedal. The slipping of the clutch caused by this practice heats and wears it badly.

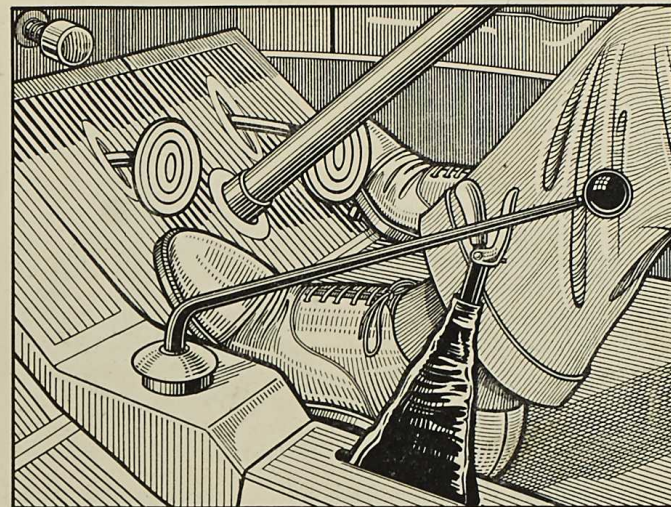

When descending a long hill, or **before** commencing a steep descent, engage one of the lower gears, and do not accelerate.

The engine will then help to retard the speed of the car. When using the brake, keep the clutch in, disengaging it at the last moment if stopping the car.

## CHANGING A WHEEL

WHEN it becomes necessary to change a wheel because of a puncture or for any other cause, the first thing to do is to pull the handbrake "hard on." The spare wheel must be lifted from the rear of the car, and before it is used, test the air pressure, and if it is not up to the correct figure, use the pump to rectify it. The proper pressures are 22 lbs. for the front, and 26 lbs. for the rear wheels.

It is important to have the car on level ground. With the wheel brace the three nuts (A) of the wheel to be removed should be slightly slackened, but only enough for them to unscrew freely later. The wheel is then jacked up.

If it is a rear wheel, the jack should be put in from the side, between the mudwing and the forward edge of the tyre, and should be placed under the rear spring between the two clips which embrace the spring leaves.

If a front wheel is to be attended to, first slacken the nuts by means of the wheelbrace. Place the jack under the front axle near but not under the big nut at the end.

The operating bar of the jack is in two parts, the upper part fits into the lower by means of a square tube (B) and is secured in that position by a spring loaded ball (B).

The head (A) of this bar which engages with the jack must be pushed well home past a locking spring which will prevent the head of the bar slipping out while the jack is in use.

The jack should be adjusted by hand as nearly as possible to the required height by turning the head round by hand before using the handle to lift the car.

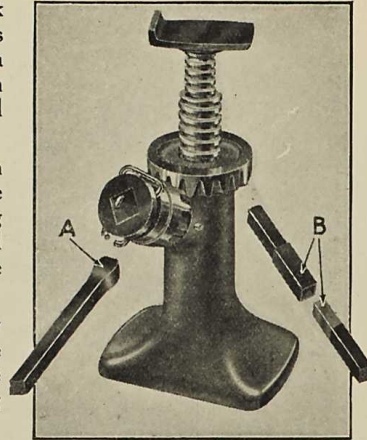

To detach the wheel from the hub loosen the three nuts (A), by means of the brace; it is not necessary to remove them entirely. Pull the wheel outwards about  $\frac{1}{4}$  in. and turn it a little to the left so that the large hole will pass over the nut. The wheel can now be pulled off the hub.

When replacing make sure that the large holes in the wheel centre are properly fitted over their pegs, and tighten the wheel nuts, each only a few turns at a time, until they are quite tight and secure.

Should difficulty be experienced upon the first occasion of removing the wheel from the hub, the wheel nuts may be screwed right off. Before replacing, wipe the outside of the brake drum and inside of the hub with an oily rag as this will ease the removal on future occasions.

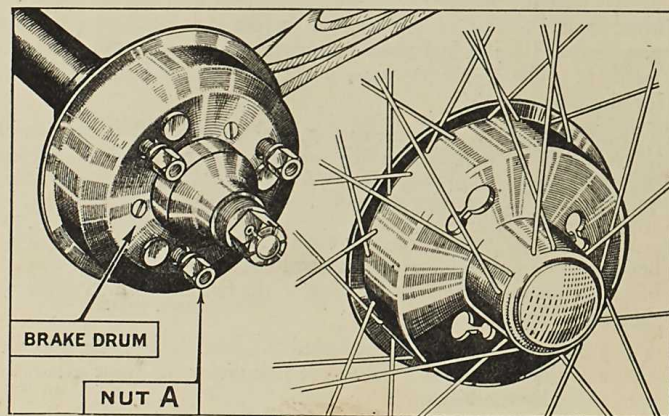

## PERIODICAL ATTENTIONS

ON this and the following page is a handy summary of all the attentions described in this handbook. The attentions under the daily, weekly, and monthly headings are based on the assumption that the maximum mileage per week does not exceed 300.

The occasional attentions should not be neglected if the car is to continue to run efficiently. When referring to the attentions below, see the lubrication chart.

**After the first few days' use tighten all nuts, particularly those on the engine cylinder head. These may loosen a little because of the heat generated, but if they receive this attention, both they and the head will remain secure against air or water leaks or loss of compression.**

### Daily Attentions

1. Examine water level in radiator and fill up to within 2 in. of the top.
2. Examine oil level in the crankcase and add more oil if necessary. The tell-tale dipper rod indicates the level of the oil.
3. Fill up the petrol tank if necessary. Care should be exercised not to overfill the tank which will contain 5 gallons.

### Weekly Attentions

1. With the grease gun charge—  
Front spring shackle pins (4).  
Rear spring pins (2).  
Front wheel swivel pins (2).  
Steering cross tube (2).  
Front brake cables (2).
2. Oil the following—  
Clutch release ring (oil lightly).  
Steering side tube joints (2).
3. Examine both sets of brakes, and adjust if necessary.
4. Test the tyres for correct pressure and examine them for cuts.



## Monthly Attentions

1. Examine the oil level in the gearbox which should contain  $1\frac{1}{2}$  pints.
2. Charge the back axle case with special lubricant, using the adapter on the grease gun.
3. Grease all the hubs as described later.
4. Charge the steering worm case through the nipple with special lubricant.
5. Oil handbrake gear, pedal gear and joints, and engine control joints.
6. Examine the battery and see that the connections are tight.
7. Give a charge of the special grease to the nipple on the fan spindle.
8. Give a few drops of oil to distributor spindle bearing.
9. Grease the front end of the torque tube.
10. Grease the splined end of the propeller shaft.

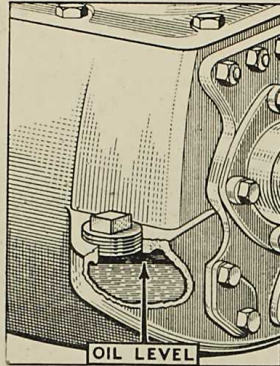

## Occasional Attentions

Examine all bolts and nuts, such as road spring clips, cylinder head nuts, wheel nuts (these three especially when the car is new), examine other parts such as steering connections, the radius rod anchorage below the gearbox, and the torque tube socket, neglect of which points might be followed by an expensive repair, and the inability to use the car for a lengthy period.

Occasionally clean the petrol filter and float chamber strainers, and the oil reservoir gauze (when the engine oil is changed); also ensure that the oil jets in the crankcase are clean. Drain the gearbox and refill with fresh oil (about  $1\frac{1}{2}$  pints).

Flush the radiator through. Clean the ignition distributor, and the contact breaker points (adjust the latter), the dynamo and starter commutators. Clean the shock absorbers, adjust the tappets, and the fan belt, decarbonize the engine and grind-in the valves. Check the alignment of the front wheels. For details of these attentions refer to the pages that follow.

## THE FUEL SYSTEM

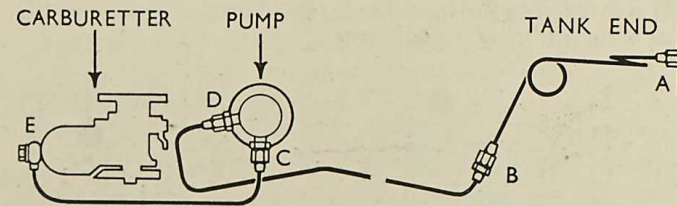

### THE PETROL PUMP.

#### How it Works.

Petrol is drawn from the tank at the rear by means of a petrol pump which delivers the fuel in the correct quantity demanded by the carburetter—no more and no less—an automatic mechanism accurately governs the operation.

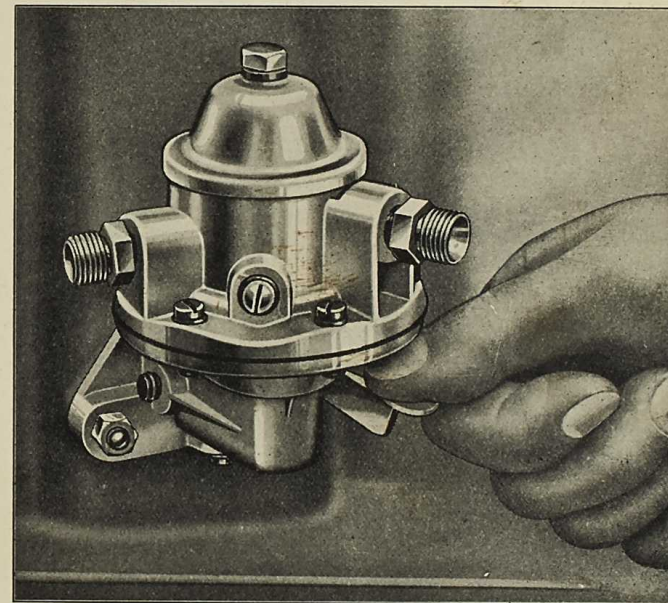

#### The Hand Priming Lever.

By revolving shaft (G) the eccentric (H) will lift rocker arm (D), which is pivoted at (E) and which pulls the pull rod (F), together with diaphragm (A) downward against spring pressure (C), thus creating a vacuum in pump chamber (M).

Fuel from the rear tank will enter at (J) into sediment chamber (K) and through filter gauge (L) and suction valve (N) into pump chamber (M). On the return stroke, spring pressure (C) pushes diaphragm (A) upward forcing fuel from chamber (M) through pressure valve (O) and opening (P) into the carburetter.

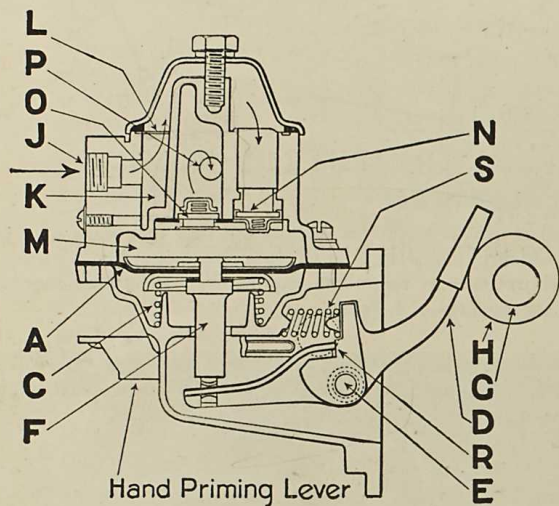

When the carburetter bowl is filled the float in the float chamber will shut off the inlet needle valve, thus creating a pressure in pump chamber (M). This pressure will hold diaphragm (A) downward against the spring pressure (C) and it will remain in this position until the carburetter requires further fuel and the needle valve opens. The rocker arm (D) is in two pieces, the outer one operating the inner by making contact at (R) and the movement of the eccentric (H) is absorbed by this "break" when fuel is not required.

Spring (S) is merely for the purpose of keeping rocker arm (D) in constant contact with eccentric (H) to eliminate noise.

### SERVICE HINTS.

Service on the A.C. Fuel Pump is available through authorized A.C. Service Stations, who are prepared with parts and fixtures for repairing all types of pumps. There are some service operations on this fuel pump that can, if necessary, be done without referring to the service station and these are given below. In some instances trouble is attributed to the fuel pump which in reality is caused by some other conditions. These should be carefully checked to avoid the needless replacement of fuel pumps.

### Lack of Fuel at the Carburetter.

Check the following instructions :—

**Petrol Tank empty.**—Refill.

**Leaky tubing or connections.**—Replace tubing and tighten all pipe connections at the fuel pump and petrol tank.

**Bent or kinked tubing.**—Replace tubing.

**Filter Cover loose.**—Tighten the nut, making certain that the cork gasket lies flat in its seat and is not broken or unduly compressed.

**Dirty filter screen.**—Remove the cover and clean the screen. Make certain that the gauze is properly replaced and the cork gasket is properly seated when reassembling and that the fibre washer is under the head of the screw.

### Leakage of Fuel at the edge of the Diaphragm.

**Loose cover screws.**—Tighten the cover screws alternately and securely. CAUTION: Do not dismantle the pump body.

NOTE.—Sometimes there appears to be a leak at the diaphragm, whereas the leak actually exists at one of the pipe fittings and the fuel has run down to the pump to the diaphragm flange, appearing to originate there.

### Flooding of Carburetter.

**Carburetter needle valve not seating.**—Check carburetter for proper adjustment, also thoroughly clean out the float chamber.

IMPORTANT.—Do not attempt to disassemble the fuel pump further than described above, because it is absolutely necessary to use a special fixture in reassembling the pump when once taken apart. When the above remedies do not correct the condition, replace with a new fuel pump sending the old fuel pump to your nearest A.C. service station.



# THE 'V' TYPE ZENITH CARBURETTOR

## Brief Working Description.

FROM the tank the petrol passes via the pump through the Union (A), the filter and the needle seating into the float chamber. The petrol rises and when reaching a certain predetermined height will cause the float to push the needle on to its seating, thus regulating the petrol flow.

The float chamber contains the main jet (1), (see illustration on next page) compensating jet (2), compensating well (3), and slow running jet (4). The petrol will then flow through the main and compensating jets and also rise in the compensating well.

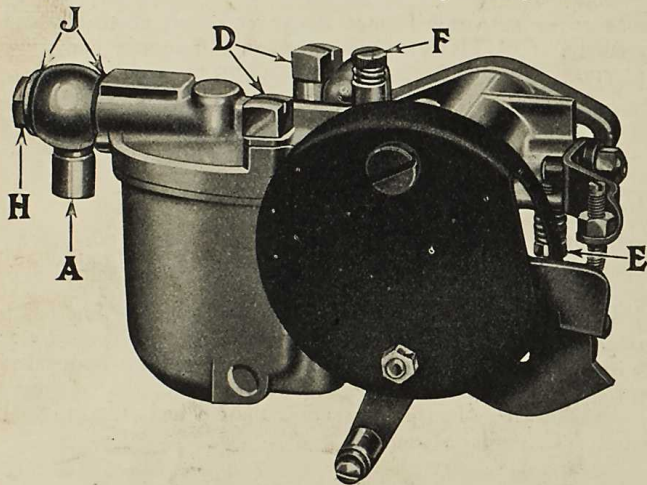

A—Union.                      E—Stop screw.                      H—Petrol connector.  
D—Holding-down screws.    F—Air regulating screw.    J—Washers.

From the jets the petrol flows along two separate channels into a common channel in the emulsion block (5), which is attached to the float chamber.

The petrol in the compensating well is in direct communication with the air and with the emulsion block. Consequently, all the petrol from the jets and well is now centred in one channel in the emulsion block. This channel leads to a nozzle (6), which projects directly into the choke tube.

### Starting.

To obtain an easy start from cold the control on the dash operating the air strangler should be fully extended and the engine should be cranked over a few times by pulling out the self-starter control knob.

Then release the knob to the first notch, which partially opens the air strangler. If the engine is then switched on it should start readily and continue to run.

It is quite in order to run for a short while with the knob in the first notch, this temporarily enriching the mixture and assisting the get-away from cold. Then as the engine warms up, release to the second notch, until, in a few minutes the engine has reached a reasonable temperature, when the knob can be pushed right in.

Difficulty can be caused by the strangler flap not closing properly, and the control wires should be examined, and if necessary shortened, to permit the flap closing fully. A choked slow running jet will also cause the difficulty, and this part should be taken out of the carburetor, and carefully cleaned.

Trouble can also be caused if the throttle is not opening sufficiently when the strangler knob on the dash is in the first notch, and in this case turning the screw (E) a little to the right will have the effect of opening the throttle a little wider.

If the mixture for slow running is weak, this can also cause difficulty in starting up, and in this case turn the regulating screw (F) in a clockwise direction, which will enrich the mixture for

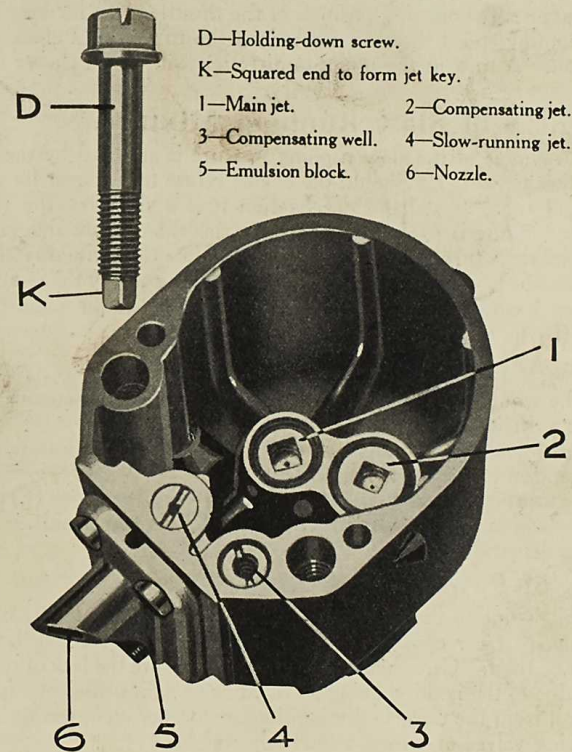

D—Holding-down screw.  
K—Squared end to form jet key.  
1—Main jet.                      2—Compensating jet.  
3—Compensating well.      4—Slow-running jet.  
5—Emulsion block.            6—Nozzle.

starting and slow running, but do not overdo this, as if the mixture is too rich, the engine will hunt and tend to choke when slow running with the engine warm.

### Adjustments.

The carburetter is delivered with the setting that has been found by extensive experimental work to be most suitable. Consequently, very little adjustment to the carburetter is needed. Indeed the user will find that a greater service will be obtained from the carburetter if the various screws, etc., are only moved when absolutely necessary.

On those occasions, however, when an adjustment is advisable (after a new car has been 'run in' an adjustment of the slow running is sometimes necessary) or when the carburetter requires cleaning, the following procedure should be observed.

### Slow Running.

Slow running is adjusted by means of the stop screw (E) and the air regulating screw (F).

### Speed of Tick-over.

The stop screw (E) determines the speed of the slow running, i.e., it adjusts the opening position of the throttle. To increase the slow running speed the stop screw must be turned in a clockwise direction. A turn in the opposite direction will give a slower tick over.

### Richness of Slow Running Mixture.

The richness of the slow running mixture is adjusted by the air regulating screw (F). Should the engine refuse to tick over for any length of time, or stall on deceleration it is a sign that the slow running mixture is weak. To overcome this the mixture should be made richer by turning the regulating screw in a clockwise direction. If the engine is inclined to "hunt" when running slowly the mixture is too rich and must be weakened by turning the air regulating screw (F) in an anti-clockwise direction.

### Poor Acceleration.

In the winter time this can be very often due to the engine not getting sufficiently hot.

If, in spite of the engine being thoroughly hot, the acceleration is bad then see to the following points.

**Slow running adjustment is too weak.**—Try the screw (F) in a richer position. **The compensating jet "2" is too small.**—Try one size larger.

### Lack of Power and Speed,

If this is due to the carburetter it is probably owing to the main jet being partially choked or a little too small, and the size larger should be tried. Care should be taken to make sure the lack of speed is not due to the ignition being retarded or to an insufficient supply of petrol from the tank, faulty ignition, or to poor compression due to leaking valves or wrong tappet adjustment.

Make sure also, that the strangler valve opens fully as if this sticks in a partially closed position it will restrict the speed of the car and increase consumption.

### Dismantling the Carburetter.

The bowl of the carburetter can be removed by taking out the holding down screws (D). One hand should be placed underneath the bowl during this operation for when the screws are removed the bowl will drop into the hand, and any petrol that is contained in the bowl can then be emptied back into the tank. On turning the bowl upside down the float will slide out and reveal the main and compensating jets at the bottom of the bowl (see illustration).

### The Jets.

The jets should be removed occasionally and be thoroughly cleaned. The holding down screws (D) are milled at the end to fit into the jets. When the bottom end is placed into the jets a spanner applied to the head of the screw will loosen the jets for removal.

When cleaning the jets it is not advisable to pass anything through them that is liable to damage them. The most satisfactory and effective method is to blow through the jets and wash them in petrol. This will remove any obstruction and leave the jets undamaged.

The sizes of all jets in the Zenith carburetter run in fives and the larger the number the larger the jet.

### The Filter.

The petrol is filtered on entering the carburetter and the filter should be cleaned from time to time. To remove the filter unscrew the petrol connection H and pull the filter out of its chamber. The filter gauze can then be thoroughly cleaned with petrol.

When reassembling the filter care must be taken to see that the washers (J) are correctly replaced.

### Alteration of the Standard Adjustment.

When you have any trouble with your engine do not assume that it is always due to the carburetter. Check the carburetter first of all for dirt and make sure that the setting is in accordance with the standard mentioned.

If these are found correct then do not be tempted to alter the carburetter until you have gone over all other likely parts of the engine, such as the sparking plugs, timing of ignition, the valves may be sticking, and things of that kind, because there are no moving parts in connection with the adjustment of the Zenith carburetter, and consequently the adjustment cannot alter of its own accord.

If the car suddenly starts to go badly, this cannot be caused by faulty carburation providing all the passages and jets are clear and there is a good supply of petrol from the main tank.

Booklet giving more detailed information about the carburetter can be obtained from The Zenith Carburetter Co., 40-44, Newman Street, London, W.1.

### "Leaded" Fuels.

The advent of "leaded" fuels (petrols containing a small proportion of tetraethyl lead) on the British market has led to a number of queries concerning their use and effect in engines.

Provided that the same reasonable attention is given to valves and adjustments as with ordinary petrols there will be no trouble when using these fuels.

The appearance of the valves when running on "leaded" fuel, differs from that associated with ordinary petrol, but this is a well recognized fact to which no significance should be attached.

The deposit from such fuels can be removed by "scrubbing" the valves and their seats with a stiff wire brush, of the type used for cleaning files (a file card), after which the valves can then be "ground in" in the normal manner.

We would recommend this method of cleaning for all valves whether they have operated with "leaded" or ordinary fuels as it eliminates the possibility of leaving small amounts of deposit on the valve seats which tend to cause damage, or prolong the "grinding in" process.



## The "NIPPY" SPORTS MODEL

The sports model has a specially tuned engine.

### Engine Lubrication

The "Nippy" is provided with a vane pump which induces a flow of lubricating oil to the rear and front camshaft bearings. A stream of oil is also conveyed to the oil jets which provides lubrication for the big ends—oil from the jets is caught in pockets on the crankshaft webs. The main bearings are lubricated by the oily vapour in the crankcase.

The reservoir should be drained after the first 500-800 miles running and the oil entirely changed after every 1,200 to 1,500 miles. Suitable lubricants are Mobiloil D, Wakefield Patent Castrol XXL Aero Shell, Essolube Racer, Motorine B de luxe, or Duckham's Aero NP3 for Summer use. In Winter, Mobiloil BB, Double Shell, Patent Castrol XL, Essolube 50, Motorine C de luxe, or Duckham's Aero NP3 (extreme cold) NP2.

For details of chassis lubrication see instructions on pp. 37 to 44.

**Normal Engine Rvs.** (safe limits). The limit for safety is 4,500 r.p.m. (approx.).

**Petrol Feed.** By Petrol Pump from a rear tank which will contain 5 gallons.

**Ignition** is by battery and coil and K.L.G. No. K1 plugs are fitted.

### Zenith 30 VEI Carburetter

This model is fitted with the Zenith 30 VEI carburetter, of which a working description is given on following pages.

The carburetter fitted to the 7 h.p. Austin Sports Model is of the downdraught type. It embodies the well-known Zenith principles of main and compensating jets. The carburetter is mounted on top of the inlet pipe, because the fundamental advantage of downdraught carburation lies in the fact that fuel is assisted by gravity into the cylinders, instead of having to be lifted against it as is the case of a normal vertical instrument.

Petrol is drawn from the tank by a pump and delivered to the carburetter through union A, passing through the gauze filter and

the needle seating into the float chamber. Referring to diagram 2' it will be seen that the float chamber which is detachable from the carburetter, holds the main jet 1, compensating jet 2, slow running jet 3, and capacity tube 4.

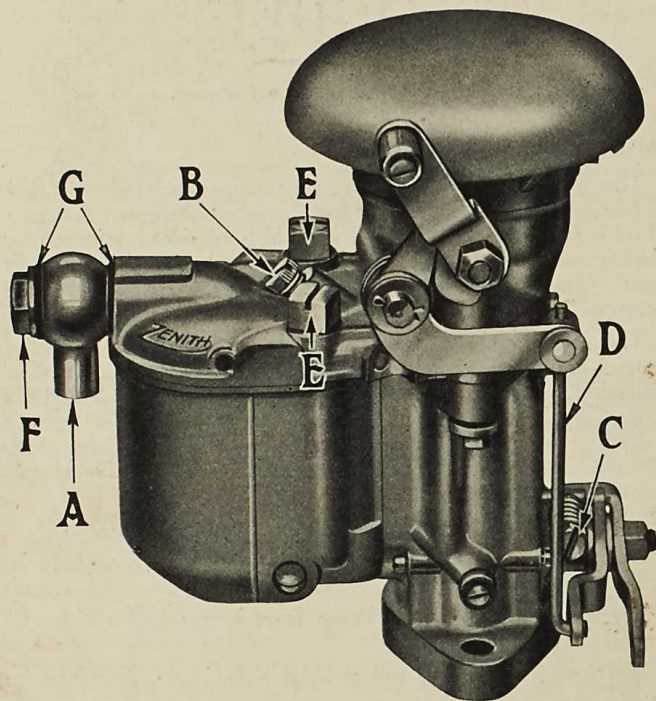

- |                                 |                           |
|---------------------------------|---------------------------|
| A. Union                        | E. Holding down screws    |
| B. Slow running adjusting screw | F. Petrol connection pipe |
| C. Throttle arm stop screw      | G. Washers                |
| D. Connecting link              |                           |

Petrol flowing into the float chamber will cause the float to rise, and when reaching a predetermined height, will close off the needle valve thereby regulating the petrol flow and ensuring a constant level in the float chamber. Passing through the main and compensating jets, petrol will rise to the predetermined level in compensating well which contains the capacity tube, and is in direct communication with the atmosphere at top, and the emulsion block by its bottom outlet. Petrol will flow along the channel underneath each jet, these uniting in a common channel in the emulsion

block 5, which is attached to the float chamber. The outlet from this common channel in the emulsion block is the nozzle 6 which projects directly into the choke tube. It will be noticed that mixture issuing from the nozzle 6 will strike a bar fixed in the choke tube which has the effect of thoroughly atomising the petrol, and assisting distribution of the charge.

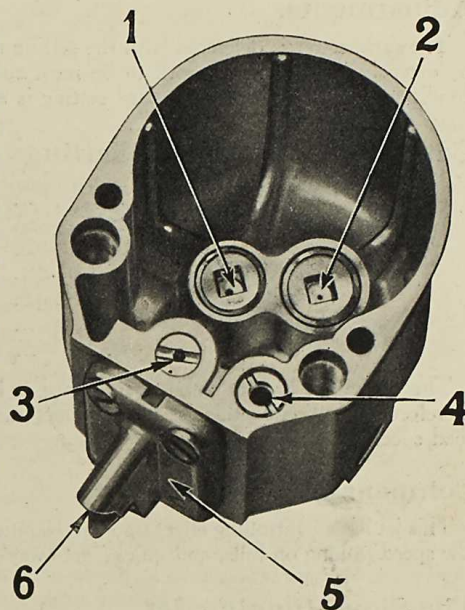

### Dismantling and Cleaning.

There are no moving parts calling for attention in the Zenith carburetter, consequently it is only necessary to periodically clean out the instrument to ensure satisfactory operation. The float chamber bowl can be removed by taking out the holding-down screws E. One hand should be placed underneath the bowl, so that when the screws are removed, the bowl can be drawn away. The petrol may be emptied into the tank, and upon inverting the bowl, the float will slide-out, revealing the main and compensating jets. One of the holding-down screws is squared at the end and can be used to remove the jets. A small screwdriver will remove the slow running jet. When cleaning the jets, do not pass anything through them that is likely to damage the carefully calibrated orifices. The most satisfactory and efficient method is to blow through them and wash them in petrol. Swill out with a little petrol any sediment which may have collected in the bottom of the float chamber. It is not necessary to remove the emulsion block from the float chamber. Unscrew the petrol pipe connection F, and withdraw the filter gauze. Thoroughly clean this part by washing in petrol. When reassembling the filter care must be taken to see that the washers G are correctly replaced.

## Adjustments.

The carburetter is delivered with the setting that has been found by extensive experimental work to be most suitable for all round conditions. The complete standard setting is as follows :—

### Carburetter Standard Settings

Choke Tube	...	...	21
Main Jet	...	...	85
Compensating Jet	...	...	55
Slow Running Jet	...	...	60
Capacity Tube	...	...	2
Needle Seating	...	...	1.5
Progression	...	...	90

The main jet has the greatest influence at high engine speeds, therefore, alteration to this jet would affect maximum power and road speed.

### Compensating Jet.

This jet has a controlling effect upon acceleration from low speeds, low speed pulling on hills, and quick "get away" from cold.

### The Slow Running Jet.

Measures the petrol supplied when the engine is idling. Petrol is drawn through this jet into a channel which has its outlet at the throttle edge. The petrol is atomised immediately on leaving the jet by air entering the carburetter at the base of the slow running adjusting screw B. The size of slow running jet should be such that smooth regular idling is provided with the slow running screw B set approximately one complete turn open. This adjustment should always be made with the engine quite hot. The speed at which the engine idles can be regulated by means of the throttle arm stop screw C. Turning this part in a clockwise direction increases the engine speed and vice versa. In all cases of difficulty with slow running, inspect the slow running jet which may be obstructed, and check the position of the screws B and C. Continued difficulty may be traced to air leaks at inlet pipe joints, etc., to the valves or to the ignition system.

### Starting from Cold.

Easy starting with the VEI carburetter is assured by an automatic air strangler interconnected with the throttle lever. The strangler is situated in the air intake of the carburetter, and is closed by fully extending a dashboard control. By means of the interconnection mechanism, this operation sets the throttle open just the correct amount to ensure an easy start.

To avoid the possibility of the strangler permitting excessively rich mixture passing into the cylinders, a diaphragm has been embodied in the strangler flap, which will open and permit extra air to enter immediately the engine fires. The quick opening and closing of this diaphragm when the engine is running will cause a buzzing noise, and this will serve to remind the driver that the strangler is still in operation and should be released. A half-way position is provided on the dashboard control, and it is advisable to run the engine for a few minutes during cold weather with the strangler in this position, before attempting to drive the car away.

### Failure to Start Readily.

The carburetter having been cleaned and the ignition system, valves, etc., checked over, the following points should be examined.

Make sure the air strangler flap closes completely when the dashboard control is operated.

Ascertain that petrol is being supplied to the float chamber by the fuel pump.

After lengthy service it may become necessary to readjust the inter-connection between strangler and throttle. Shortening the connecting link D will increase the opening of the throttle.

When cars are used in very hot climates or at high altitudes, a slightly weaker setting than normal is usually required.

### Valve Tappet Clearance on Sports Model.

The most efficient setting on the tappets is that which gives a clearance of .004 in. **when the engine is very hot.** It is not easy to make the necessary adjustments when the engine is really hot—there is always the danger of burnt fingers—so to compensate for the expansion due to a hot engine, the tappets should be adjusted when the engine is cold, thus :—inlet .008in., exhaust, .010in.



# THE TYRES

## Tyre Pressure

The minimum pressures to which both front and back tyres should be inflated are:—

Model.	Standard Tyre Equipment.	Inflation Pressures.		
		Front.	Rear—1 or 2 Passengers.	Rear. Fully laden
Open Models ..	3.50—19	22	22	26
Closed Models ..	4.00—17	22	22	26
Export Cars ..	4.00—18	22	22	26

Lbs. per sq. in

If, because of wear or other causes, the steering develops a tendency to wander or show signs of wobble, the tyre pressure should be increased. It is important that both front tyres should be kept at the same pressure. In any event there is no reason why the pressure should not be more than the minimum figure given, as some drivers prefer their tyres harder than do others.

As tyres form such a large item in the running costs of a car it is advisable to give them periodical examination and attention.

A cursory glance should be given daily to see that none of the tyres is unduly slack, and a weekly test with a suitable gauge should be made to verify the pressures. Occasionally examine the tyre treads for cuts; bad cuts should be vulcanized.

Now and again examine the locking nuts which secure the valves to the rims. These are sometimes loosened when the dust caps are unscrewed. If they are loose, the tube may "creep" and damage to the valve seating, causing a leaky tube, be the result. Therefore, keep the locking nuts tight.

## Tyre Wear

Because of the turning-in of the wheels towards each other at their lowest point, it has been found that the front near side tyre wears at its outer edge. The camber of the road tilts the car towards the left, and the tyres are distorted. It is in the action of recovering their correct shape, immediately after contact with the road, that they suffer abrasion, made more damaging because the gritty substances now used on tarmac roads accumulate on the near side and the wheel is running in this grit for most of the time it is on the road. So change your front wheels over and thus equalize the wear between the tyres. When both tyres have become worn on the outside edge, change the back wheels with the front wheels. Subsequently the tyres can be turned round, bringing the least worn edge to the outside. If the front tyres should show premature wear at any time suspect the tracking of the front wheels. Have it checked, to see if it is correct, and, if necessary, adjusted (see pages 61 and 62).

# The IGNITION SYSTEM

THE Coil Ignition Equipment is provided with an automatic advance mechanism, which relieves the driver of the necessity of constant adjustment of the hand ignition control. Its advantages are particularly evident when accelerating, and during hill climbing, the danger of pre-ignition, knocking or "pinking" being very much reduced.

The device is housed in the distributor body and it consists of a centrifugally operated mechanism by means of which the ignition is advanced in proportion to the engine speed.

Very little attention is needed to keep the ignition equipment in first-class condition; we advise that it is inspected occasionally and the following instructions on lubrication, cleaning and adjustment should be carried out.

## The Distributor

The distributor cover can be removed on springing aside its two securing clips. The electrodes "B" and "H" and the inside of the cover are then accessible for cleaning with a dry duster. See that the

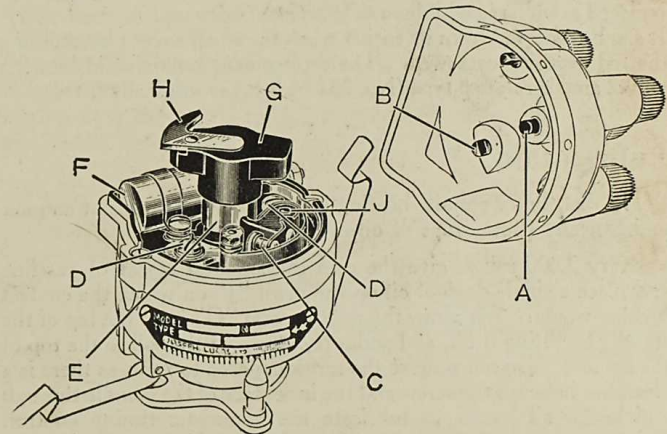

DISTRIBUTOR AND CONTACT BREAKER.

- |                |                  |                            |
|----------------|------------------|----------------------------|
| A Carbon Brush | D Locking Screws | G Rotating distributor arm |
| B Electrodes   | E Rotating Cam   | H Rotating Electrode       |
| C Contacts     | F Condenser      | J Contact breaker pivot    |

carbon brush "A" is clean and moves freely in its holder. The contact breaker points can be similarly cleaned if required. Normally the gap between the contacts will not require adjustment until a considerable mileage has been covered, unless the points have burned. The work of re-setting the points, when this has occurred, should be left to a skilled mechanic. For the normal adjustment, first turn the engine by the starting handle



until the points are seen to be fully open. Then, using the ignition screwdriver, slacken the two screws "D" in the contact plate, and move the plate until the gap is set to the thickness of the gauge. After making the adjustment care must be taken to tighten the locking screws.

### The Coil

The coil needs no attention apart from keeping the terminals tight and the top clean.

### Ignition Switch and Warning Lamp.

The key, by means of which the ignition is switched on, should be withdrawn when the engine is not running; this will ensure that the battery does not discharge by the current continuing to flow through the coil windings.

The warning lamp on the instrument panel will light when the ignition is switched on and the engine is not running. This lamp also lights when the engine is only idling. Should the bulb of the warning lamp fail, this will not affect the ignition, but it should be replaced as soon as possible so as to act as a safeguard to the battery. It can be removed from its socket when the small cover plate holding the red glass is unscrewed. The replacement bulb should be a 2.5 volt .2 amp screw cap type (No. 252 M.E.S.) as originally fitted.

### Lubrication.

The distributor spindle bearing is lubricated by means of an oiler which needs a few drops of oil every 1,000 miles.

Every 3,000 miles, give the cam the slightest smear of vaseline and place a single drop of oil on the pivot "J" on which the contact breaker works. Withdraw the rotating arm "G" from the top of the spindle by lifting it off, and add a few drops of thin oil to the top of the spindle. Do not remove the screw exposed to view, as there is a clearance between the screw and the inner face of the spindle through which the oil passes to lubricate the automatic timing control. Take care to refit the arm correctly and to push it on to the shaft as far as possible.

### Renewing High Tension Leads to Distributor and Coil.

When the high tension cables show signs of perishing or cracking, they should be replaced. Use only 7 m.m. rubber covered ignition cable for all high tension leads.

To make a connection to the distributor or coil terminals, thread the knurled insulating nut over the lead, bare the end of the cable for about  $\frac{1}{4}$  of an inch, thread the wire through the brass washer provided, and bend back strands. When the moulded nut is screwed home, the cable will be securely clamped, and the nut will support the cable, and prevent vibration and fracture.

### Ignition Faults.

When the engine will not fire, or fires erratically, the trouble may arise from the carburetter, or petrol supply and not the ignition. A partially choked jet, an incorrect petrol level, or air leaks into the induction system may be the faults. Equally, sooted plugs can be suspected, when dismantling and cleaning them will remedy the trouble. If the battery has run down, or its terminals have worked loose, quite obviously there will be no spark, and the same results can be expected if the distributor electrodes and contact breaker have been neglected and are dirty.

The coil can be tested by removing the cable from the centre socket on the distributor cover, and holding the end of this cable, about  $\frac{1}{4}$  inch from some metal part of the car, while the ignition switch is on and the engine is turned. A strong and regular spark will result if the coil is in order. Clean the top of the coil, and ensure that its terminals are tight before making this test.

To test for short circuits in the low tension wiring (the cables from the switchboard to coil, coil to distributor, and distributor to chassis) which would equally cause irregular running, have the engine turned while the ignition is switched on, and watch the ammeter reading. It should rise and fall as the contact breaker points close and open. This test will also indicate if the contact breaker is functioning correctly. If the contacts remain open, or do not fully close, the reading will not fluctuate.

If the high tension cables from the distributor to the plugs are not securely attached to the distributor, misfiring may occur. Or, if the rubber insulation on these cables shows signs of perishing and cracking, there may be leakage of the current giving rise to the same symptoms. Renewing the cables is then the remedy.

If after verifying these points, the trouble remains undiscovered, the equipment should be examined and tested by the nearest service depot of the makers.

## Sparking Plugs

The sparking plugs with which the "Seven" is fitted are K.L.G., type 777.

The gaps between the firing point of the central electrode and the earth points are set at .015 to .018 an of inch. A too wide gap would cause misfiring, especially at high speeds, and under heavy pulling at low speed with an open throttle, while a too small gap causes poor idling.

After the first thousand miles it may be necessary to clean the plugs, because an excessive amount of oil is sometimes used, and this causes a deposit of carbon on the interior insulation of the plugs.

Type 777 is a three-piece plug—the gland nut is a separate component. To clean a plug, the insulated centre A must be removed from the plug body C by unscrewing the gland nut B. When B is unscrewed the central electrode may be withdrawn. Wipe the lower mica insulation carefully with a petrol soaked rag. If the carbon deposit is hard, soak the electrode in petrol for an hour or so, this will soften the carbon. The mica insulation D should be thoroughly cleaned and polished, and the central electrode scraped clean.

Scrape out the inside of the body and clean the earth points. Wash the plug body in petrol and dry it.

To reassemble, see that the internal washer is in place before inserting the electrode. Tighten the gland nut to secure gas tightness, reset the earth points E to .015—.018in. To do this it may be necessary to bend each earth point toward the central electrode.

**The central electrode must not be levered toward the earth points.**

If the sparking plug washer has been completely flattened, replace it with a new one; most garages stock them and they are cheap.

Poor grade oil, improper carburetter adjustment, low grade petrol, excessive use of choke, faulty cables, distribution points out of adjustment—all these may cause fouled sparking plugs.

Sparking plugs should be renewed every 10,000 miles.

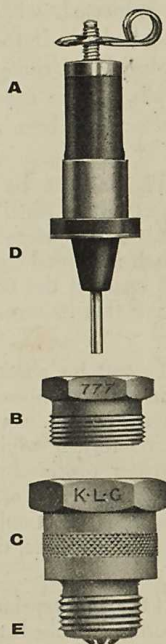

## TIMING THE IGNITION

In the event of the distributor (with or without the dynamo) being removed from the car, upon replacement, the timing of the ignition must be re-set.

The first operation is to remove all the sparking plugs, except the front—No. 1—and turn the crankshaft by the starting handle until compression is felt. This means that No. 1 cylinder would have been the next one to fire.

### Flywheel Timing Marks

Remove the clutch pit cover and a line will be seen on the back of the flywheel, marked 1 and 4 (see illustration on page 41). The line is parallel to the throws of the crankshaft, and when this line is vertical it naturally follows that Nos. 1 and 4 pistons are at the top of their stroke. In this case, however, we are only dealing with No. 1. Now turn the flywheel until this line is approximately  $\frac{3}{4}$  of an inch before the top centre. (We cannot quote a definite figure as this depends on the characteristics of the particular engine). This is the position at which the spark should take place at the sparking plug, when the ignition is fully advanced.

Remove the distributor cover by springing back the two securing clips. The screw for the clip to the distributor casing is slackened, and the casing turned anti-clockwise until the contact breaker points just begin to open; this is the position at which the spark occurs. The screw should then be re-tightened. The direction in which the rotating arm of the distributor is pointing should be noted, and the distributor cover refitted, and secured in its proper position by the two clips. A small projection on the casing fits in a recess near one of the clips to secure the distributor cover in its correct position.

If after this the ignition seems too much or too little advanced, it can be adjusted by loosening the clamping screw of the distributor fixing clip, and moving the distributor casing relative to the clip a slight amount, anti-clockwise to advance the timing, or clockwise to retard. Only an extremely small movement is required, then tighten the screw. If the leads from the distributor have been disconnected for any purpose, they must be replaced correctly in the sequence marked on the distributor cover, thus :—1, 3, 4, 2, which is the firing order.

# The COOLING SYSTEM

**T**HE cooling of the engine is maintained by a capacious radiator which should be filled, with rain water, if available, up to within about 2 in. of the top of the filler. The capacity of the radiator, pipes and cylinder jackets is 9-10 pints.

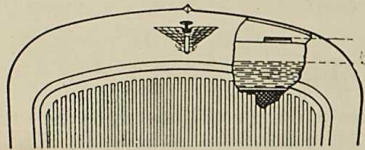

**In Winter** an anti-freezing mixture should be added to the water in the radiator, because in very severe weather the water may freeze and thus damage the cylinder block or the radiator it-

self. Moreover, when an anti-freeze mixture is used, there is no need to draw off the water to prevent damage by frost.

If such a mixture is not used, care should be taken to see that the water is drained off completely, for, in case of freezing, it will do harm by lodging in small spaces, and fracture of the cylinder block may result. In Great Britain, the climate does not very often call for the cooling system to be drained, but it is well to err on the right side and take due precaution against damage if frost be threatened.

To prevent the gradual formation of deposits in the cooling system, with consequent impeding of the circulation, the use of hard water should be avoided. Rain-water, syphoned from the top of the barrel where it is clean, should be used, or, failing that, water that has been boiled.

Occasionally flush out the water cooling system by opening the draining cock at the bottom of the radiator, and allowing water to run through; renewing the supply say for five minutes, preferably by means of a hose.

## Causes of Overheating

Overheating may be attributed to one or more of the following causes:—

Slack fan belt. The belt can be tightened by turning the fan spindle in its bracket after loosening the clamping-nut.

Excessive carbon deposit in cylinders. See "Running Adjustments."

Running with ignition too far retarded.

Using oil of poor quality, or lack of oil in the reservoir. See "Engine Lubrication."

Partial choking of the oil jets. See "Engine Lubrication."

Improper carburetter adjustment, giving a mixture too rich or too weak. See "The Carburetter."

Failure of water to circulate, because of choked radiator tubes, water level below the tops of the radiator tubes, or loss of water through leakage from connections.

Overcooling is almost as bad as overheating. If the engine tends to be too cool, use a radiator muff, or possibly, in winter the fan belt can be removed without the engine running too hot.

The entire circulating system should be thoroughly flushed out occasionally. To do this open the drain tap at the bottom, place a hose in the filler, and run fresh water through.

Trouble arising from a damaged radiator generally necessitates its dismantling and despatch to a repair depot.



## THE GREASE GUN

THE type of grease gun supplied in the tool kit of all Austin cars is known as the Enots "Autolub" gun, and it incorporates features by which the chassis lubrication of the car is greatly simplified.

Instead of screwing down the plunger spindle, in order to fill the ram of the gun, once the gun is charged all that is necessary is to keep pushing the ram of the gun against the nipple until the contents are exhausted.

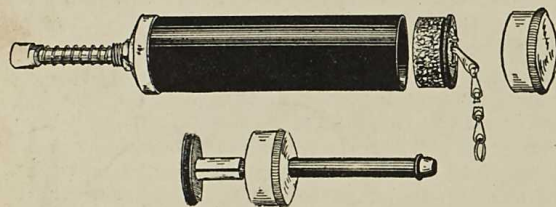

The ram is automatically returned to its extended position by a spring. This action creates a vacuum in the gun by means of a valve, and thus refills the high pressure chamber contained in the ram.

The ram is used for forcing grease through nipples, and the adaptor for lubricating the back axle with oil. For this operation, first replace the screw-on cover of the ram, then remove the end cap from the barrel of the gun, pull out the cork plunger by means of the chain, and charge the gun, to about three quarters of its capacity. Put the cap of the adaptor on the open end of the gun, and after removing the plug from the back axle, place the end of the adaptor into the greasing hole, and grasping the barrel, push. This will inject a large quantity of lubricant quickly.

When charging the gun, it should be filled with lubricant to about *three quarters* of its capacity.

## LUBRICATION

THE correct lubrication of any piece of machinery is of the utmost importance, but for the modern high-speed automobile engine, which operates at sustained high temperatures and speeds, it is **absolutely essential** that only oils of the highest quality and correct grade be used. Inferior oils, or unsuitable oils, will almost inevitably cause excessive wear in an unduly short time.

**We cannot over emphasise the folly of using so-called "cheap" lubricants.**

Modern cars use comparatively little oil, so that the cost of using a good lubricant is negligible compared with the cost of using inferior oil. Good lubricating oil ensures that you always get out of your car the best performance that it can give; it reduces carbon deposit making frequent decarbonising unnecessary; it makes starting easier, thereby avoiding deterioration of the battery; it reduces engine wear and eliminates avoidable causes of mechanical breakdown with possible heavy repair bills.

Lubricants represent the smallest proportion of your expenditure on the upkeep of a car, so that it is obviously false economy to use other than the best.

But even the best oil becomes contaminated with certain impurities during use. In the engine, these may be unburnt fuel, carbon, metallic particles, moisture, etc., and although the oil itself does not deteriorate the presence of these impurities must reduce its efficiency as a lubricant and in time cause avoidable wear. Oils of the best quality resist contamination, and consequent wear, to the greatest extent, nevertheless it is imperative that the crankcase be drained periodically to remove foreign matter, and subsequently refilled with fresh clean oil.

Drain the crankcase immediately after a run when the oil is warm, and therefore fluid and thoroughly agitated. It will then carry away as much of the contamination as possible. **Never flush the crankcase with paraffin**—some will remain in the sump to contaminate the fresh oil, and, in addition, it may loosen, but not entirely remove, certain deposits which are best left undisturbed until the engine is overhauled.

Rinse gauze filters in petrol and allow to drain before refitting. **Do not wipe with fluffy rags.**

Oil in the gearbox and back axle becomes contaminated with metallic particles from the gear teeth and these will cause unnecessary wear of the bearings unless removed. These units should also be drained periodically and may be flushed with a thin oil. This should be allowed to drain thoroughly, after which the unit should be filled to the correct level with fresh oil.

### Choice of Lubricants.

Some lubricants are lighter in colour and appear thinner than others. However, the colour of an oil or its appearance at atmospheric temperatures give no indication as to its efficiency under operating conditions and temperatures. Therefore, oil should never be judged by colour or apparent consistency.

The following are the lubricants we officially recommend, each of them having the high grade standard of quality required by our Research Department, and all of them having proved entirely satisfactory in extended service. Further, they all have adequate distribution at garages and filling stations.

**Engine.**—(Summer): Mobiloil "BB," Triple Shell, Patent Castrol XL, Essolube 50, Motorine C or Duckham's Aero N.P.3.

(Winter): Mobiloil "A," Double Shell, Patent Castrol AA, Essolube 40, Motorine M or Duckham's Aero N.P.3. (Extreme cold N.P.2.).

(Sports Models—Summer): Mobiloil "D," Aero Shell, Patent Castrol XXL, Essolube Racer, Motorine B de Luxe or Duckham's Aero N.P.3.

(Winter): Mobiloil "BB," Double Shell, Patent Castrol XL, Essolube 50, Motorine C de Luxe or Duckham's Aero N.P.3. (Extreme cold N.P.2.).

**Gear Box.**—Mobiloil "BB," Triple Shell, Patent Castrol XL, Essolube 50, Motorine C or Duckham's Aero N.P.3.

(Sports Models): Mobiloil "D," Aero Shell, Patent Castrol XXL, Essolube Racer, Motorine C de Luxe or Duckham's Aero N.P.3.

**Rear Axle and Steering Box.**—Mobiloil "C," Shell Spirax, Castrol D, or Jaba Oil C.

**Wheels, Hubs and Grease Gun.**—Mobilgrease No. 4, Shell R.B. Grease, Castrol Heavy.

**Upper Cylinder Lubrication.**—Gargoyle Upper Cylinder Lubricant, Shell Upper Cylinder Lubricant, Wakefield Castrollo, Petmix, or Motorine U.C.L.

**Distributor and Hand Oilcan.**—Gargoyle Velocite Oil D, Shell Household Oil, Wakefield Oilit, Essolube 30, Price's Cycle Lubricating Oil or Duckham's Aero N.P.O.

**Springs, Rusted Parts or Squeaks.**—Voco Penetrating Oil, Shell Penetrating Oil, Castrol Penetrating Oil, Essolube 30, Price's Penetrating Oil or Duckham's Easing Oil.

### The Engine

The recommended lubricants are of the correct quality and viscosity for our units. The matter of the proper grade of oil is very important both in relation to the pump used to circulate the oil, and the gauge to register the pressure; if a very thick oil were used on a cold day, the pump might be strained or the gauge broken. After the first 500-800 miles running, drain the original oil from the reservoir by removing the plug in the bottom, while the engine is hot, and refill with new oil.

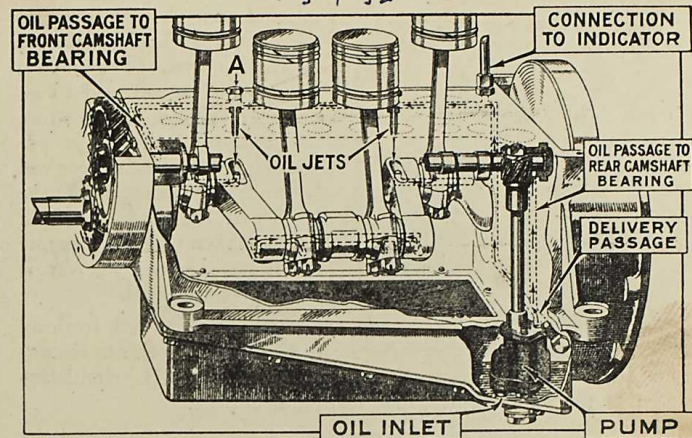

After the first re-filling it is advisable to change the oil in the engine entirely after every 1,200 to 1,500 miles running.

Every 2,400—3,000 miles remove the oil reservoir. The gauze oil tray will then be accessible for removal. Scrupulously clean the gauze and remove all dirt from inside the reservoir and replace them. Carefully remake the joint with the packing washer, covering both sides of it with grease. When tightening up the nuts holding the oil reservoir to the crankcase, do not pull up one nut tight, but tighten each nut equally, a little at a time. See that the drainplug is screwed up tight, then fill the crankcase with oil to the maximum level as shown on the dipper rod. About half a gallon will be enough to fill.

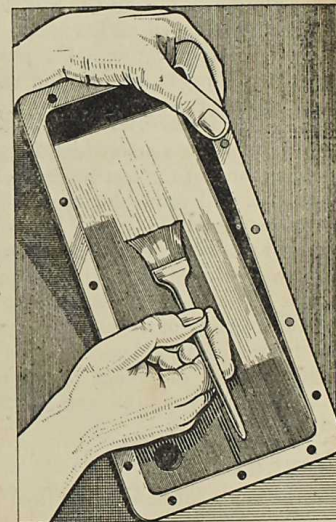

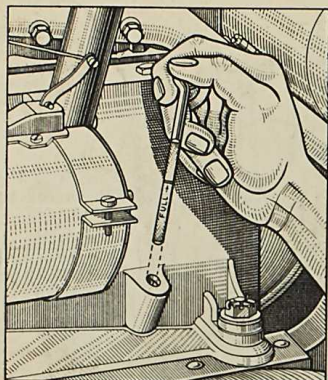

Always inspect the level of the oil, and add enough to fill to the correct level before starting on a long journey. The oil level should not be allowed to go below  $\frac{1}{4}$  inch on the bottom of the dipper rod. It is advisable to wipe the dipper rod before taking the reading of the level, and the reading should only be taken when the engine is not running and the car is on the level ground.

After refilling with fresh oil to the correct level, run the engine for a few moments to check that the oil is circulating and that the oil pressure gauge reading is correct.

The main bearings of the engine are of the roller type, and the oily vapour in the crankcase is quite sufficient to lubricate these.

The pistons are also lubricated by the oily vapour.

Lubrication of the big-ends is effected by catching oil from the pump-fed jets in pockets on the crankshaft webs.

It is advisable to make sure these jets are always clear, and to do so, the plugs over the jets (A) (see illustration on page 39) should be occasionally removed and a piece of stiff wire, not above  $\frac{1}{8}$  in. diameter, inserted through the jets. This prevents foreign matter accumulating in the oil jets and choking them.

### The Oil Pressure Gauge

An oil pressure gauge which records up to 10 lbs. is now part of the equipment of the instrument board of the Austin Seven.

The dial will probably record the maximum pressure when the engine is started from "cold," but as the engine warms up in running, so the oil will become more fluid and the pressure will fall quite low—it may even record only one pound. This, however, is sufficient because if the oil is circulating that is all that is necessary.

An obstruction in the oiling system while the car is running would be indicated by a sudden rise in the pressure on the gauge.

This unusual difference to the normal registration on the dial, would be quickly noticed, and the cause of the variations ascertained and set right.

### Gearbox

In the angle formed by the floor and the raised portion which is over the gearbox, on the near side, is a movable cover secured by a screw. Unscrew and remove this cover. Immediately below it is the plug of the hole through which oil is poured into the gearbox.

The same grade of oil, as is used for the engine is most suitable for the gearbox. Do not use thick gear oil, otherwise seizure of bearings may result.

Maintain the oil at the correct level, i.e., bottom of the filler plug hole.

The gearbox should be drained, and refilled to the correct level after the first 1,000 miles and every 5,000 miles subsequently. Quantity approx.  $1\frac{1}{2}$  pints.

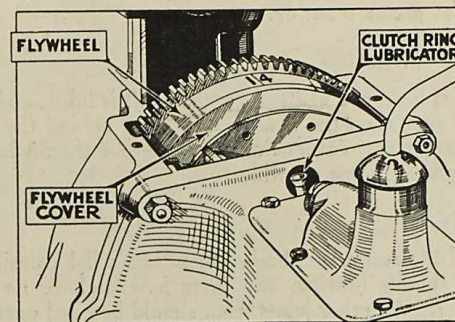

### Clutch

The clutch surfaces being of a fabric material must be kept free from oil and grease, or the clutch will fail to grip. Lubricate the operating ring lightly through the oiler, as shown on the sketch once a week.

### Steering Gear

To obtain easy steering it is important to give it regular attention as regards lubrication. The grease gun nipple is on the top of the worm case, and if a charge is given once a month it is sufficient to lubricate the bearings of the worm and worm wheel and also lubricate the worm itself. However, if too much is injected at this point, it will get up the column and exude round the steering wheel. The bearing at the top of the column, just under the steering wheel can be given a little oil from the oil-can. The steering connections on the side rod are best lubricated by means of an oil-can which ejects the oil under pressure, into the sockets, and the nipples at the end of the cross rod should be given a charge of grease once a week.

### Rear Axle

For the rear axle, attention every 1,000 miles should be sufficient. A special oil is used and is injected into the axle from behind and underneath, using the special adaptor on the grease gun barrel. First remove the plug, then place the end of the adaptor into the oiling hole, and grasping the barrel of the grease gun, push. When replacing the plug see that the washer is not omitted. The plug also serves as an oil level indicator, therefore do not replace the plug at once, which will give time for the superfluous oil to run out, if too much lubricant has been injected. This is most important, because if the brake axle is overfilled, the lubricant may leak through on to the brakes and render them ineffective.

Drain the rear axle every 5,000 miles, and replenish to the correct level.

## Torque Tube

There is a raised casing in the centre of the floor. Behind the front seats, on this casing, is a sliding panel, which is removed to give access to the greasing point on the front end of the torque tube, which requires grease monthly.

## Propeller Shaft

The front, splined end of the propeller shaft is lubricated through a hole in the tunnel on the near side and just behind the gearbox. A small leather flap covers the hole. Grease should be applied through the grease nipple monthly.

## Brake Gear

On each of the rear wheel brakes there is a self-lubricating bush for the cam spindle bearing, and there is, therefore, no greasing point on either. All other joints, etc., should be oiled once a week.

The front wheel brake cam spindle is lubricated from the swivel pin as shown at B, in the illustration on page 43.

## Front Axle

The swivel pins are lubricated with the grease gun and should receive attention once a week.

## Radius Rod Anchorage

Oil should be applied occasionally to the cups and ball flange forming the radius rod anchorage on the front cross member, just below the rear of the gearbox.

## Fan

The fan bearing requires a charge of grease once a month through the nipple on the fan bracket.

## Road Springs

The rear ends of the rear road springs where they are attached to the axles are provided with greasing nipples, and should be given a charge once a week if the car is continually used. To ensure the best results it is essential that the road springs should be lubricated. A penetrating oil should be used. It can be sprayed from the container or applied with a brush. If the rear wheels are removed the springs are fully accessible.

## Front Hubs

Remove the road wheel. Turn the hub until the plug "A" is at the top. Screw out the plug and apply the adapter of the grease gun, and inject about a quarter of a gun full.

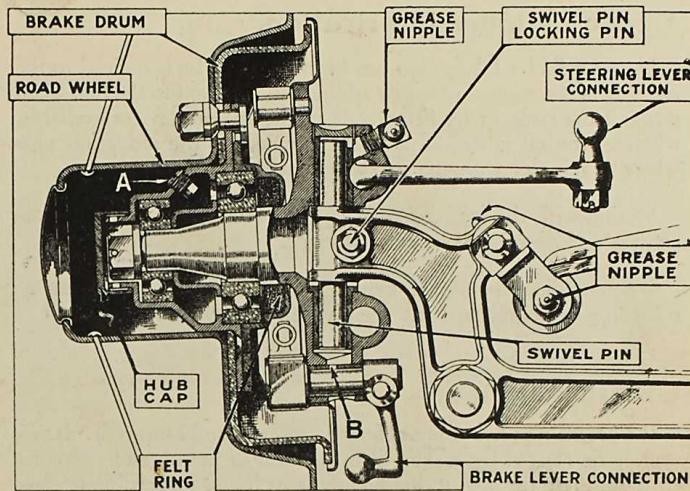

The front hub in section, showing the grease plug A.

It is important that the hubs are not given too much grease otherwise it will penetrate to the brakes to render them ineffective

Once a month, or every 1,000 miles is often enough for this attention.

## Rear Hubs

Remove the road wheel. Turn the wheel until the plug "A" is at the top. Inject grease into the hub; about the same quantity as was recommended for the front hubs is a suitable amount. Do this not more frequently than every 1,000 miles.

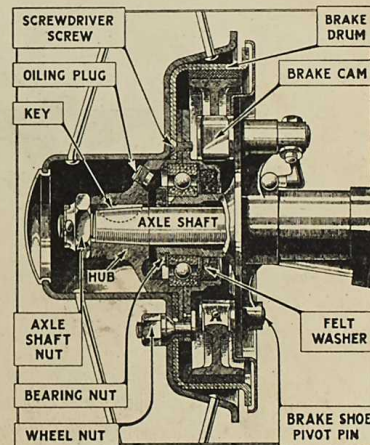

A section of the rear hub, showing the Plug A.

## Upper Cylinder Lubrication.

Upper cylinder lubrication has been found to be beneficial to the running of the engine, either by adding the lubricant to the fuel when refilling the tank, or by fitting one of the special devices available, whereby the oil is sucked into the engine, via the induction pipe where it mingles with the explosive charge.

Mixing with the fuel, however is quite satisfactory and saves the trouble and expense of an extra fitment.

When adding the upper cylinder lubricant to the fuel, do so according to the instructions given with the various brands of oil.

## Grease Nipples

If a grease nipple becomes choked, unscrew and remove it. It can usually be cleared by soaking it in paraffin or petrol, and syringing either of these through it, but should it be found impossible to clear it, fit a new nipple in its place.



# THE LAMPS

## Headlamps.

THESE lamps are provided with an electrically operated anti-dazzle device for operation by the foot switch. When the switch is moved to the "dip" position, the near-side head lamp beam is dipped and turned to the near-side of the road, while at the same time, the off-side head lamp is switched off, thus causing no discomfort to approaching traffic.

The dipping of the head-lamp beam is effected by a movement of the reflector. This is made in two parts; the centre portion is pivotted in a fixed rim which is in turn secured to the body. Movement of the reflector is controlled by means of a solenoid and plunger which, when the current is switched on, tilts the reflector to give the dipped beam.

## Removing the Lamp Front and Reflector.

To remove the lamp front, slacken the fixing screw at the bottom of the lamp and swing it aside from the slot. The front can then be withdrawn. When replacing, press the front on to the lamp body, locating the top of the rim first. Finally swing the screw into the slot and tighten it to lock the front into position.

To remove the nearside reflector, withdraw the fixing screw at the back of the lamp. The reflector can then be withdrawn by dislocating the tongues of the two fixing brackets rivetted to the reflector rim from the slots in the lamp body. The offside reflector can be removed together with the front.

## Aligning and Focussing.

To obtain the best results from the lamps it is essential that they are in good alignment and that the bulbs are focussed correctly.

Alternative positions are provided for the head lamp bulb in its holder. Each position to be tried for the best projection of light.

To align the lamps, slacken the single fixing nut, then move the lamp on its adjustable mounting to the desired position, finally locking the adjustment by tightening the nut.

## Fuse.

A fuse is provided with the electrical dipper unit to protect the equipment in the event of the reflector failing to function properly. The fuse is of the cartridge type, and is carried in spring clips alongside the dipping mechanism. If the reflector fails to function, remove the fuse from its holder and see whether there is a break in the fuse wire. A spare fuse is clipped to the reflector bracket.

If the fuse should blow repeatedly, and the cause cannot be found, have the reflector examined at the nearest Lucas Service Depot.

## Side Lamps

The lamp front can be removed by twisting it to the left and withdrawing.



### **"Stop" Tail Lamp.**

The front of the stop tail lamp can be removed for bulb replacement when the fixing screw is slackened sufficiently.

### **Bulb Sizes**

The sizes of the bulbs are :— Head, 618 S.V.; Side, B.A.S. No. 8S; Tail, B.A.S. No. 8S; Stop, B.A.S. No. 8S; Dash, B.A.S. No. 8S.

### **The Reflectors**

The reflectors of the lamps are covered with a protective coating, and any marks can be easily removed by means of a soft cloth. On no account use any metal polish on reflectors.

## **ELECTRICAL EQUIPMENT**

**T**HE lighting and starting units on the Austin Seven car are arranged for wiring on the single wire system, the return path of the current being provided by the frame instead of a second wire. It is essential that all units are in metallic contact with the frame.

Should difficulties arise that cannot be understood or remedied from the information given below, application should at once be made to the Austin Service Department or the nearest service depot of the makers of the equipment.

### **Dynamo**

The dynamo is a simple self-regulating third brush machine. The only parts calling for any attention are the commutator and brushes, which are readily accessible when the cover is removed. The commutator surface must be kept clean and free from any oil or brush dust. It may be cleaned with ordinary soft rag, but if it has been neglected use fine glass paper. Blow away any carbon dust, see that the carbon brushes are wearing evenly and that the arms move freely on their pivots. To fit a new brush, it is only necessary to remove the single screw to withdraw the worn brush from its holder.

The dynamo bearings are packed with grease before leaving the works and do not require oiling. When the car is overhauled, it is advisable to have the machine dismantled and the bearings repacked with grease. This work is preferably carried out by a Lucas Service Depot.

### **Dynamo Field Fuse.**

A fuse is provided in the dynamo field circuit to protect the machine in the event of anything being wrong in the charging circuit, e.g., a loose or broken battery connection. The fuse is of the cartridge type and is housed along with the half charge resistance

in the cut-out and fuse unit on the engine side of the dash (see page 49). If the dynamo fails to charge the battery at any time (indicated by a discharge reading being given on the ammeter during day time running) inspect the fuse and if it has blown, replace it with the spare fuse provided, after inspecting the charging circuit wiring for loose or broken connections, and remedying. This fuse must not be replaced while the engine is running. If the new fuse blows after starting up, the cause of the trouble must be found, and we advise that the equipment is examined by one of our Service Depots. Never fit any fuse other than the Lucas standard fuse as originally fitted. The size of the fuse is marked on a coloured paper slip which can be seen inside the fuse.

### **Starting Motor**

The commutator is accessible on removing the sheet metal band cover. The unit requires very little attention beyond keeping the commutator clean and free from oil, brush dust, etc., as in the case of the dynamo. Remember that although the starter will turn the engine over, however stiff, it is advisable to crank the engine over by hand two or three revolutions as this will considerably diminish the load for starting.

If the starter pinion jams in mesh with the flywheel ring when operating the starting motor switch, usually it can be released by putting the gear lever into top gear, and moving the car bodily backward and forward. If this plan is ineffectual the starter will have to be dismantled.

Never use the starting motor to propel the car, as it throws too severe a strain on the battery and the motor.

If the engine does not start at the first attempt, do not press the starter switch until the engine has come to rest. If this precaution is not adopted, the starter ring teeth on the flywheel, or the starter pinion teeth, may be damaged.

### **Lighting and Charging Switch and Ignition Lock and Key.**

A key is provided by means of which the ignition switch is moved so that the engine can be started. When the slot into which the key fits is in a vertical position, a spring releases the key and it may be withdrawn. The ignition is then cut off. To switch on the ignition, insert the key and turn to the right, until the slot is in a horizontal line. The key cannot be withdrawn while the ignition is switched on, it must be turned off and the slot be in a vertical position first.

The lighting and charging switch positions are :—

"Summer Half Charge."—Dynamo giving about half its normal output.

"Winter Full Charge."—Dynamo giving its full output.

"Side."—Side Lamps and tail lamp on.

"Head."—Head Lamps, side lamps, and tail lamp on.

The dynamo automatically gives its full output when the lamps are switched on. To switch on the ignition, press in the key and turn it to the right; to switch off, turn it to the left.

### Dipper Switch.

The dipper switch has two positions—one to give the normal driving light, and one to dip the near side head lamp beam and at the same time switch the offside headlamp off.

If the headlights are on full, a touch of the left foot on the switch alters the lights to the "dip and switch" position, and they remain so until another touch returns them to the "full on" position.

### Ammeter

The centre zero ammeter indicates the rate at which the battery is being charged or discharged under all conditions. For instance suppose 2 amperes are consumed when the side and tail lamps are switched on, and that the ignition coil takes 2 amperes, then if the dynamo is generating 7 amperes the meter will show 3 amperes on the charge side of the scale. This is the current in excess of the lamp and ignition load that is available for charging purposes.

The ammeter gives an indication that the system is functioning satisfactorily. For example if no reading is given on the charge side of the scale when the ignition and charging switch is in the "Winter Full C" position and the car is running at say 20 m.p.h. with no lights on, then a fault in the dynamo charging circuit is indicated.

To determine the output of the dynamo, switch off all the lights and add the amount of current used for ignition (about 2 amperes at normal speeds) to the reading given on the ammeter.

The amount of current used for ignition may be somewhat higher than the above figure when starting. The ammeter does not indicate the amount of current used by the starter.

### Cut-out and Fuse

The cut-out is mounted together with two fuses as one unit, which also forms a junction box and incorporates the half-charge resistance for the dynamo. The cut-out automatically closes the charging circuit as soon as the dynamo voltage rises sufficiently above that of the battery. When the dynamo voltage falls below that of the battery, the reverse action takes place, the cut-out opens and thereby prevents the battery from discharging itself through the dynamo.

The cut-out is accurately set before leaving the works, and does not need any adjustment and is therefore sealed.

The two fuses are of the cartridge type. The one marked "AUX" is connected in the accessories circuits, and will blow in the event of a short circuit in the wiring of the electric horn, windscreen wiper, and other units connected to the "AUX" terminal, the indication that the fuse has blown being the failure of these units.

The other fuse marked "DYN" protects the dynamo, and is connected in the dynamo main circuit. The indication of a blown dynamo fuse is that the dynamo will fail to charge, no charge reading being given on the ammeter under normal daytime running conditions. Spare fuses are provided in cases of emergency. Before fitting a replacement fuse, examine the wiring of the equipment the fuse protects for loose connections or short circuits, and remedy. If the new fuse blows and the cause cannot be found, we advise the owner to have his equipment examined at a Lucas Service Depot.

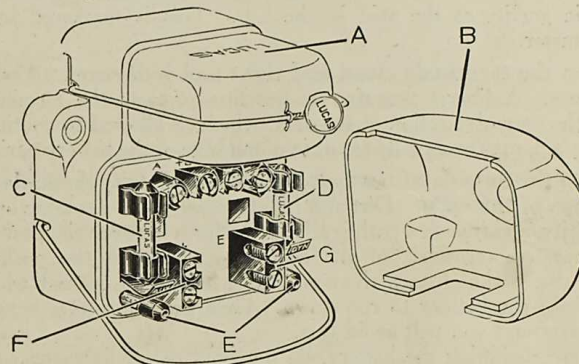

Cut-out and fuse unit type CFR.

- |                                            |                                                   |
|--------------------------------------------|---------------------------------------------------|
| A—Cut-out cover.                           | E—Spare fuses.                                    |
| B—Fuse and terminal cover.                 | F—Positive supply terminal for accessories        |
| C—Fuse in auxiliary accessories' circuits. | G—Negative (or earthed) terminal for accessories. |
| D—Fuse in dynamo field circuit.            |                                                   |

Never fit any fuse other than the standard Lucas fuse as originally fitted. The size of the fuse is marked on a coloured paper slip inside the fuse.

### Battery

The battery is the reservoir of the energy generated by the dynamo, and upon its satisfactory functioning depends the starting and running of the car.

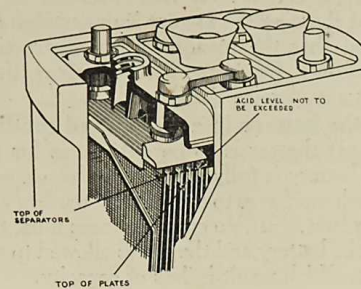

The amount of attention needed is small and need take only a few minutes. Follow the directions given here and your battery will last longer and give better service.

**Once a month unscrew the filler caps and pour a small quantity of distilled water into each of the cells to bring the acid just level with the tops of the separators.**

Distilled water can be obtained from any chemist and most garages. Do not use tap water, as it contains impurities detrimental to the battery. If any acid is accidentally spilled from the battery, it must be replaced by a dilute sulphuric acid solution of the same specific gravity as the acid in the cell. This is measured by a hydrometer.

**Keep the terminals clean and tight and well smeared with vaseline.** A liberal smearing of vaseline protects the terminals from the corrosive action of the acid, which, if allowed to continue unchecked, may eventually result in a breakage of the battery wiring.

**Keep the outside of the battery clean and dry, particularly the tops of the cells.** Dirt and moisture will form a conductor of electricity, and if such a path is allowed to form between the positive and negative terminals of the battery, or between the positive terminal and the chassis, there will be a leakage of current which will cause the battery to run down. Give the cell tops a regular wipe over and you will avoid this.

When examining the battery, do not hold naked lights near the vent plugs as there is a possible danger of igniting the gas coming from the plates.

**Once a month, make a point of examining the health of the battery by taking hydrometer readings.** The operation is quite simple and need not take long. There is no better way of ascertaining the state of charge of the battery.

The specific gravity readings are:—1.285 to 1.300, battery fully charged; 1.210, about half discharged and 1.150 completely charged. These figures are given assuming the temperature of the solution is about 60 degrees F.

**First filling and charging the battery.** When a battery arrives empty (as in the case of cars sent abroad) the first thing to do is to fill and charge it. For instructions, see special leaflet supplied with each uncharged battery. If the operation of mixing acid, filling the cells and charging the battery is undertaken by the owner, it should be noted that the manufacturers' instructions must be followed very carefully. Of course if it is desired, the battery can be filled at almost any Service Station.

**Do not leave the battery in a discharged condition for any length of time.** If the car is to be out of use for any length of time, see that the battery is fully charged and about every fortnight give it a short refreshing charge to prevent any tendency of permanent sulphation of the plates. In no circumstances must the electrolyte be removed from the battery and the plates allowed to dry, as certain changes take place, which result in loss of capacity.

## The Electrolyte

When the battery arrives empty (as in the case of cars sent abroad) the first thing to do is to fill and charge it.

This means that a fluid is prepared composed of one part (by volume) of pure brimstone concentrated sulphuric acid with three parts (by volume) of distilled water. Mix these in a glazed earthenware vessel. Great care must be taken in this operation. Add the acid in very small quantities, almost drop by drop, and stir with a glass rod.

**Never add the water to the acid.** This is highly dangerous and a serious explosion may result.

This mixing generates heat, and it is important that the electrolyte (as the mixture is called) should not be used in the battery before it has been allowed to cool. Pour the electrolyte into the cells of the battery by means of a lead, glass or celluloid funnel, until it completely fills the cells to the top of the vent hole. Allow the battery to remain in this condition for 10 minutes or so, then put in more acid solution so that each cell is again filled to the same point with electrolyte. The electrolyte will have a specific gravity of 1.285 when fully charged. Batteries may be charged at almost any service station. Batteries should stand at least twelve hours after their first filling before charging is begun.

## Direction Indicators.

Every two to three months, raise the indicator arm and apply one drop of thin machine oil to the two hinged joints between the arm and the operating mechanism. Only the merest drop of oil should be added, any excess may affect the working of the solenoid mechanism.

If at any time, the arm fails to light up when in operation, examine the bulb. To remove the bulb, switch the indicator on, and then, supporting the arm in a horizontal position, move the switch to the off position.

Now withdraw the bulb holder, which is clipped into the underside of the arm, by means of the metal tongue provided. Do not attempt to remove the bulb holder while the indicator is switched on, as this may cause a short circuit, and so damage it.

On some models, move aside the small trigger projecting from the underside of the arm, when the cap of the bulb holder will spring open. Fit a new bulb in place of the one which has burnt out and refit the cover.

Bulbs fitted: No. T63F, 3-watt festoon type.

If the direction indicators or electric petrol gauge fail to function, examine the fuse protecting them (this is fitted on the dash near the cut-out); if it has blown, inspect the wiring for a short circuit. If the new fuse blows, the cause of the trouble must be found, and we advise that the equipment is examined by a Lucas Service Depot.

## The Electric Petrol Gauge.

The electric petrol gauge is automatic and registers the contents of the petrol tank. It is active only when the ignition is switched on, consequently when the tank is being replenished, first switch off the

ignition to stop the engine, then switch on again and the needle on the dial will record the amount of spirit which is poured into the tank. The gauge is very unlikely to fail, but in this eventuality, Messrs. S. Smith and Sons (M.A.), Cricklewood Works, London, N.W.2 (the makers) or their depots will give prompt service.

### Electric Horn

These horns, before being passed out of the works, are adjusted to give their best performance and will give a long period of service without any attention; no subsequent adjustment is required.

If the horn becomes uncertain in its action, giving only a choking sound, or does not vibrate, it does not follow that the horn has broken down. First ascertain that the trouble is not due to some outside source, e.g., a discharged battery, a loose connection or short circuit in the wiring of the horn, or a blown fuse.

It is also possible that the performance of a horn may be upset by the horn becoming loose on its mounting.

This can be ascertained by removing the horn from its mounting, holding it in the hand and pressing the push. If the note is still unsatisfactory, do not attempt to dismantle the horn, but return it to Messrs. A. Rist for examination.

### Electric Windscreen Wiper.

To start, pull out the curved handle and swing it aside so as to move the cleaning arm into position on the screen. Then pull out the switch knob and give it a spin. To stop the wiper push in the knob. Then pull out the curved handle and turn into the top of the switch knob. This locks the arm out of the line of vision of the driver and also ensures that the wiper is switched off.

The wiper requires no attention: all moving parts are packed with grease during assembly and no lubrication is required.

When cleaning the windscreen, the wiper arm can be easily lifted from the screen, but care must be taken that it is not forced from side to side.



### WIRING DIAGRAM.

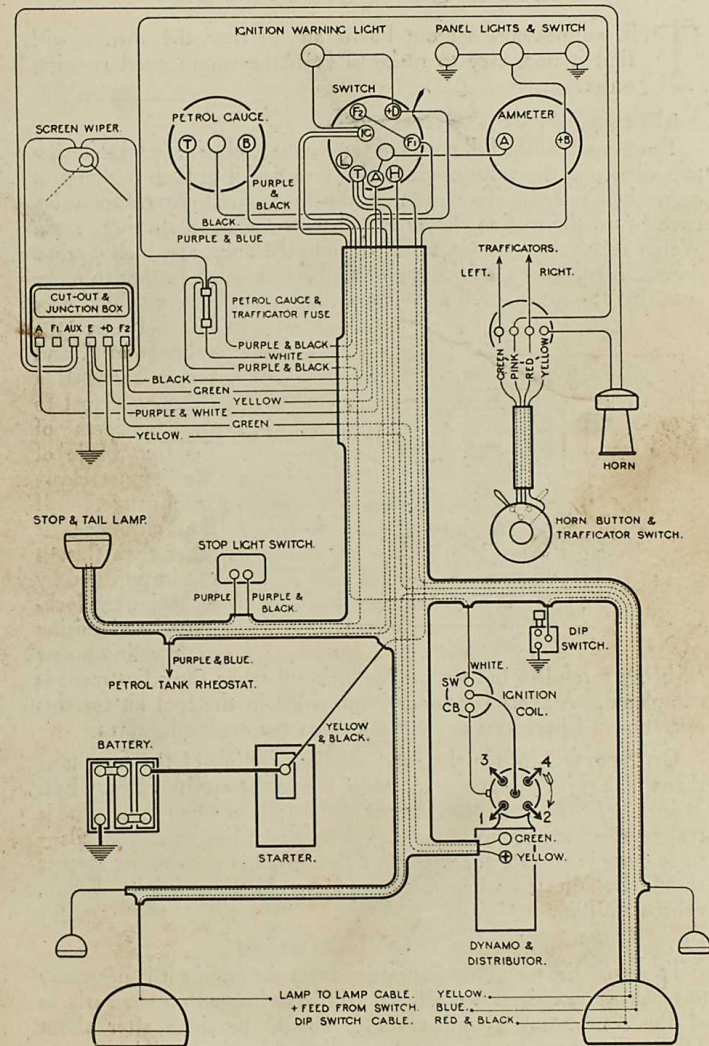

# RUNNING ADJUSTMENTS

THE adjustments set out below are all that the owner will find it necessary to make to keep the car in good running order.

## Valve Tappet Adjustment

To ensure that the full power of the engine is obtained and to maintain silence in the valve operation, it is essential to keep the tappets correctly adjusted. To make this adjustment, first remove the valve cover, turn the engine slowly round with the hand starting crank. Watch each valve open in turn and note the point at which it stops descending. Now turn the engine half a revolution further to make sure that the cam is well away from the tappet.

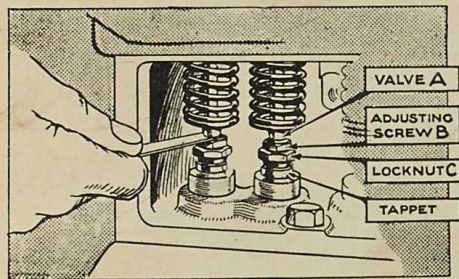

There should now be between the valve stem A and tappet screw B a clearance equal to the thickness of the thin blade of the "tappet clearance gauge." If the clearance is other than this, it can be adjusted by loosening the lock-nut C and raising or lowering screw

B, being careful to tighten up the lock-nut when the adjustment is completed. A special spanner is provided in the tool kit for this operation. Check this adjustment when the engine is warm.

**On Sports Models** the most efficient setting of the tappets is that which gives a clearance of .004in. **when the engine is very hot.** It is not easy to make the necessary adjustments when the engine is really hot—there is always the danger of burnt fingers and hands—so to compensate for the expansion due to a hot engine, the tappets should be adjusted when the engine is cold, thus:—inlet .008in., exhaust, .010in.

## Cleaning Combustion Chamber

To secure the maximum efficiency from the engine it is necessary to remove the carbon deposit that will have formed on the surfaces of the combustion chamber. This should be done after about 2,000 miles running. When the cylinder head is off it may be advisable to take this opportunity of grinding-in the valves, although this will need a longer time for the work to be carried out. In any case, it is recommended that after about 4,000 miles the work of grinding-in the valves should be undertaken.

First drain off the water through cock under the radiator. Detach the top water tube from the head. Disconnect the high tension wires from the sparking plugs. Remove the nuts holding down the head. Then take hold of the head at each end and lift it off.

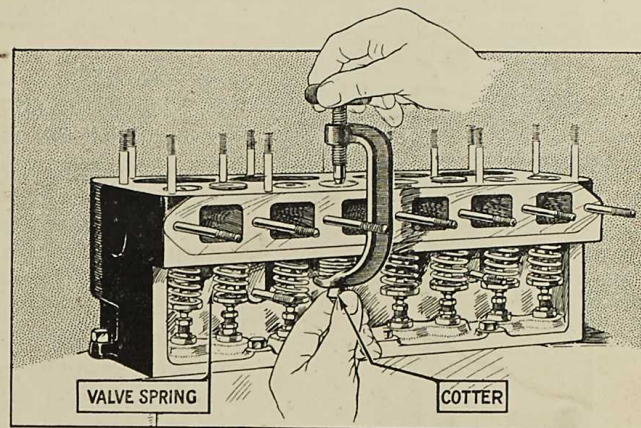

This should be fairly easy to do, without damaging the joint washer, which should, in the ordinary course, be in a condition to be replaced.

When working at the partly dismantled engine a spanner or perhaps part of the engine may be dropped on to the "live" starter terminal, thus causing a short and possible damage. Therefore, disconnect the battery cable at the battery; "Safety First."

## Removing the Carbon

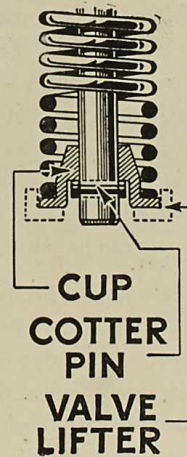

When the head has been removed the valves and tops of pistons will be exposed to view. All dirt or deposit should be removed by carefully scraping with a sharp tool. Before grinding-in the valves it will be necessary to remove the inlet pipe, and exhaust manifold and carburetter, then disconnect the carburetter control, and the airstrangler wire. The valve cover with its washer, can be removed on undoing the two milled nuts. Each valve spring must be lifted by means of the special tool provided to allow the cotter pin to be withdrawn; then remove the

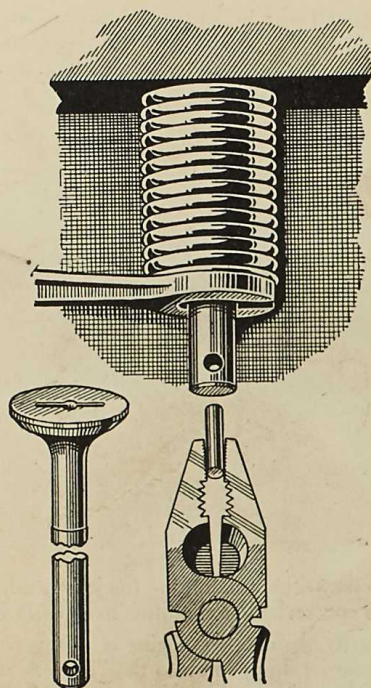

spring. The valve is now free to be rotated on its seat when the tappet screw has been lowered clear of the stem. After the valve is cleaned a little grinding compound should be smeared evenly on its face and the valve rotated backwards and forwards by means of a screwdriver, advancing it a step at short intervals until the pitting is removed. Lift each valve a little from its seating at the end of each step—this allows some of the grinding compound to enter between the two faces and facilitates the cutting action. Care should be taken that none of the compound

enters the cylinders and the valve and seating should be wiped quite clean after the operation. Note that it is essential for each valve to be ground-in and refitted on its own seating, as indicated by the number on the valvehead. The valves are numbered from 1 to 8, starting from the front. It is also desirable to clean the valve guides. This can be done by dipping the valve stem in petrol or paraffin and moving it up and down, and round, in the guide until the dirt is removed. Then the valve should be cleaned, and the stem smeared with graphite grease and re-inserted in the guide; the valve spring and cup being fitted up round it. The valve lifter is then used as before to compress the spring so that the cotter pin can be refitted.

See that all the slots in the heads of the valves are in line, because this indicates that the holes in the valve stems into which the cotter pins are to be inserted will all be facing the operator. See that the cotter pin is placed properly in the hole in the valve stem, so that the cup fits evenly over it, otherwise the pin will fly out. It is easiest to fit the end valves first, and work toward the centre. The cotter

pin is inserted in the valve stem, and then the lifter screw is slackened to allow the valve spring cup to come down over the cotter pin.

Pliers will be found more convenient than fingers for removing and replacing valve cotter pins.

Check the clearance by means of the tappet clearance gauge, and as a measure of caution, repeat the checking after the car has run 100 miles, as the valves have a tendency to bed down again. When refitting the manifolds ensure that the joints are good. The cylinder head joint washer should be replaced with the side stamped—"Austin Cooper Gasket"—downward, with a little graphite grease smeared over each side, to make a good joint and to prevent it sticking when the head has next to be lifted. When replacing the head take care to tighten the nuts evenly.

It is advisable to tighten the nuts in the order shown on the sketch.

Don't turn them right up at the first operation, but go over them a second time and tighten them securely and fully.

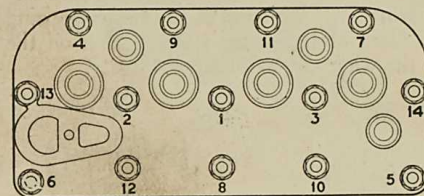

The method will ensure that the head has been evenly replaced, and the nuts on the studs uniformly and securely tightened.

Don't forget after replacing the head, to refill the radiator with water

### Lifting the Cylinder Block

For access to the pistons (except the piston crowns), and the connecting rods, or for fitting a new tappet plunger or guide, it is necessary to lift the cylinder block. The three nuts on the distributor side are easily removed, also the three barrel nuts on the valve side can be removed without difficulty when the valve cover has been taken off. For access to the nut at the front of the cylinder block the dynamo and casing with the fan bracket and fan, must be lifted clear. First pull the ignition leads and the lead from the coil, from their sockets in the distributor cover. Disconnect the dynamo, and remove the fan belt. The casing is secured by three set screws and a nut. With the casing removed,

the front cylinder block nut is accessible. For access to the rear nut of the block, remove the inspection cover of the clutch pit from the toe plate. Then remove the flywheel housing cover, which is secured by two set-screws to the flywheel housing. Next remove the lower hose connection, and the cylinder block can be lifted. When refitting the cylinder block it is necessary to use sleeves on the pistons to compress the rings. These piston ring sleeves are among the extra tools obtainable from the Service Department of the Austin Motor Co., Ltd., It will be necessary to retime the ignition after re-assembling.

### Adjusting the Brakes

Both the hand brake and the foot brake operate on all four wheels. They require adjusting when the hand lever can be pulled right back to the full travel on the rack, and when the pedal can be pushed nearly to the floor-board without either brake holding the wheels. The car should never be taken out when in this condition, but should be attended to at once.

To adjust the foot brake: Under the car and approximately under the foot controls is a wing nut. This nut is reached by raising a disc in the floor just in front of the driver's seat. Pull on the hand brake—this enables the wing nut to be turned easily.

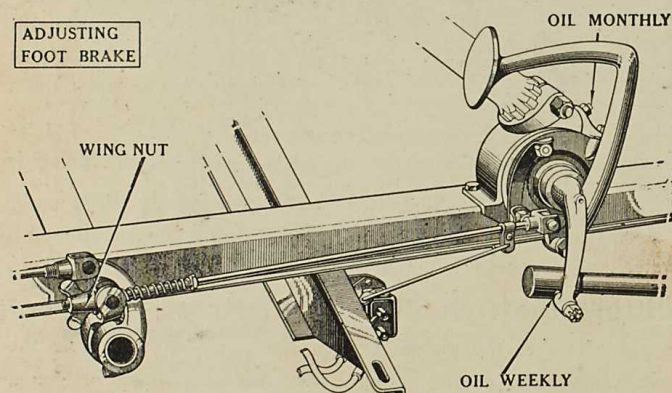

The wing nut must be screwed towards the front of the engine until the brakes go full on when the pedal is depressed about 2in. When the pedal is up, the brake shoes should not rub the wheel drums in which they operate.

For adjusting the rear brakes, which may be necessary after re-lining the shoes, an individual adjustment for each of the rear brake cables is provided. A screwed end, to which the cable is attached, screws into the front fork-end, which secures the cable to the compensating tube lever. By removing the fork-end from the lever (a pin, secured by a split-pin, holds it) the fork can be screwed further on or off the screwed cable end to effect the adjustment.

The cable must not be twisted while this is being done. To test whether both brakes

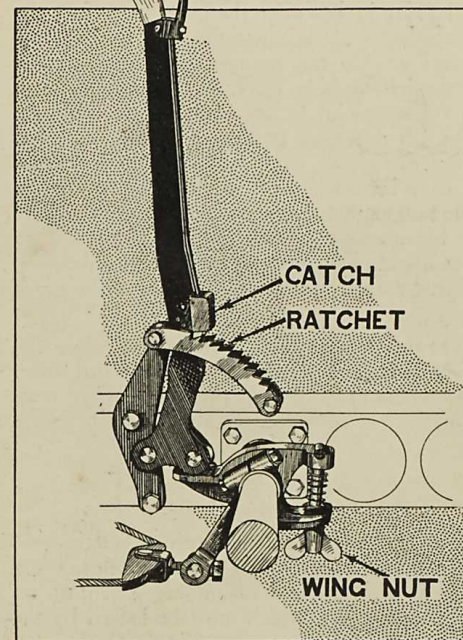

engage equally at the same time, jack-up the back axle, and with the brake pedal pressed down, turn each wheel by hand to judge the braking effect.

Having done this the hand brake lever should be adjusted. This is done from under the car, by hand. A wing nut is provided by means of which the slack between the hand brake lever and the brake gear is taken up.

The hand brake lever must be pushed forward to its limit; that is the brake must be

right off. Then turn the wing nut clockwise until the hand brake lever will only move freely one notch in the rack without moving the brake mechanism.

If this short movement is made without beginning to operate the brakes, it indicates that the brake shoes will not rub against the drums when the hand brake lever is in the "off" position; and that the adjustment has been properly made.

### Re-lining the Brakes

To re-line the brakes it is necessary first to remove the wheel, and then the brake drum, by unscrewing the three screwdriver screws which secure it to the hub; and, before the shoes can be removed for re-lining, the hub and wheel bearing must be extracted. For this a special hub extractor is supplied in the tool kit.

### Rear Brakes

For the rear wheel brakes (see illustration on page 44) remove the axle shaft nut, having first taken out the split pin; and extract the outer portion of the hub by screwing the extractor on the

screwed end, and turning the extractor bolt which bears on the end of the axle shaft. Remove the key from its keyway in the axle shaft. Next remove the bearing nut, having knocked back the tang of the washer locking it, and prise the inner portion of the hub or felt housing together with felt packing and bearing, off the end of the axle casing. Do not damage the paper washer between the hub and the felt housing faces, as it is important to make a good joint on reassembling, to prevent the hub lubricant penetrating to the brake. If this inner portion of the hub does not come off the axle casing easily, the outer half should be refitted as closely as possible, using the wheel nuts to draw the two halves together. Then use the hub extractor a second time, and so remove the hub together with bearing and packing. The brake shoes can now be pulled off the cam and pivot pin, and the springs unhooked. The old linings can then be detached by punching or drilling out the rivets.

The brake linings should be clamped to the shoes while the riveting is in progress, as it is essential that they should bed down on the shoes over their whole area. When the linings have been rivetted in position, bevel off at each end for about  $\frac{1}{4}$  inch with a coarse file.

### Reassembling

To reassemble, replace the shoes with their springs on the cam and pivot pin. Replace the inner portion of the hub or felt housing with the bearing and packing on the axle casing end, and push up home by tightening the bearing nut, which must be locked by the locking washer in the same way as before dismantling. Replace the paper joint washer on the felt housing face, insert the key in the shaft, push the hub over the axle shaft, on the key, and draw it up to the felt housing by the wheel nuts on their studs. When the joint faces of the hub and the felt housing are together replace the axle nut and tighten securely up to the hub boss. *Remember to insert the split pin through the nut.* Then remove the wheel nuts from the hub, fit the brake drum, and insert and tighten the three screwdriver screws.

### Front Brakes

For the front brakes (see illustration on page 43) the operation is somewhat similar. Having removed the wheel, and the brake drum, secured by the three screws, remove the hub cap, and screw on the extractor in its place. Before proceeding further, remove the plug (A) from the hub, or unscrew it for about three turns; otherwise it will foul the outer hub bearing when the hub is being extracted. Draw off the outer portion of the hub. The axle nut and split pin will now be accessible for removal. Replace the outer portion of the hub and pull it to its original position by the wheel nuts, as in the case of the rear wheel. By means of

the extractor draw off the hub with its bearing and packing. The brake shoes are left clear for removal. On reassembling remember to fit a new split pin through the axle and nut; there is a hole in the end of the hub through which the pin can be inserted.

It is always necessary to re-line all four brake shoes on the one axle at the same time, and after the re-lining it may be necessary to slack off the brake adjustment before the brake drum can be replaced.

After re-lining the brakes make sure that the hubs contain sufficient lubricant, and re-adjust the brakes if necessary.

### Adjustment of Steering

If after continual use slackness should be felt in the steering, two adjustments are available:—To take up the play in the column, loosen the nut which tightens the bracket supporting the steering outer column to the instrument board, unscrew locking peg (A) and clamping bolt (B) then turn the sleeve (C) with the special spanner provided for the purpose, until the play has been removed. Do not screw the sleeve in too tight or the steering will then become stiff. Having adjusted the sleeve correctly, screw in the locking peg so that it enters one of the slots of the sleeve, tighten up the clamping bolt, and the supporting bracket to the instrument board.

To take up the clearance between the worm and worm wheel, due to wear, remove the locking plates and slacken the three nuts (D) holding the cover (E) to the worm casing, then turn adjusting screw (F) so as to slightly draw the cover in the direction of the worm. Care must be taken that the worm wheel is not brought too tightly into mesh with the worm or it will make the steering exceedingly

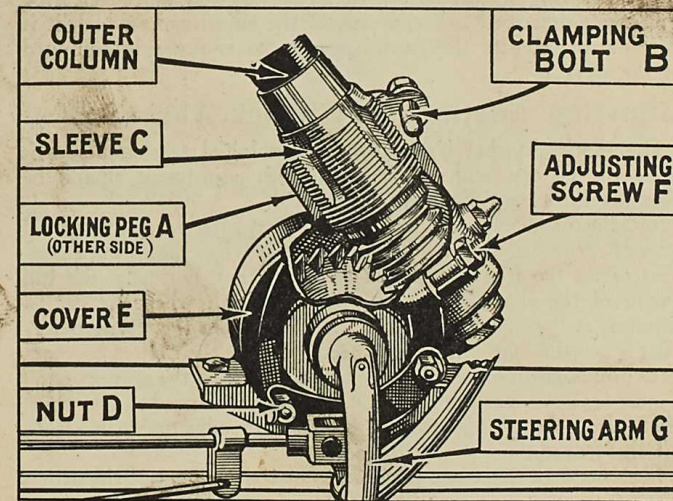



hard and stiff. Having made the adjustment be sure and tighten up the three nuts (D) and lock them with the locking plates.

Should it be desirable to remove the steering worm wheel from the casing, it is only necessary to slacken the adjusting nut (F) and remove the three nuts (D) when the cover (E) can be withdrawn together with the worm wheel and steering arm. The steering column can be withdrawn by first slackening locking peg (A) and clamping bolt (B), and unscrewing the sleeve (C). These adjustments, again, should be left to an Austin agent to effect.

### Tracking Adjustment

One of the causes of premature tyre wear is the front wheels being out of track. The wheels, if they are correctly tracking should not be parallel, but should be  $\frac{1}{8}$  in. closer between the rims in front of the axle than they are behind. This difference, or "toe-in" as it is called, allows for working clearances of the steering connections, and any slight spring of the parts, so that when the car is running the wheels are as near parallel as possible. If on checking this difference, it is greater or smaller than  $\frac{1}{8}$  in. the tracking should be adjusted. This is not difficult to effect. It is necessary to remove the cross tube lever, on the near side, from the swivel axle. It is secured by a nut on the front of the swivel axle, under which there is a spring washer. With this done, the steering cross tube is freed at the near side for the adjustment. On the clamping bolt of the steering arm jaw being slackened, the jaw can be screwed further on, or off, the cross tube, for so many complete turns as may be necessary. This movement will enable the correct adjustment to be attained; then the clamping bolt is re-tightened. On refitting the cross tube lever to the axle, tighten the nut securely, with the spring washer under it. This, as well as the steering adjustment described below, is one of the adjustments which it is advisable to leave to the Austin agent who is properly equipped for the work.

### Adjusting Austin Front Shock Absorbers

The shock absorber is set to a certain initial tension before it leaves the factory, and no change in this adjustment should be necessary for a very considerable time.

Re-adjustment may only become necessary after several thousand miles of car travel, and should be made only when the spring movement seems too free. It should be noted that, normally, the full benefit of the shock absorbers will not be felt when the car is travelling at low speeds, as under these conditions the spring movement is very limited, but, as the speed increases their effect becomes more pronounced, especially over bad roads when the spring action is most severe. Testing should, therefore, be carried out at comparatively high average touring speeds and adjustment made to suit these conditions.

The frictional resistance required to effectively control the action of the springs is comparatively small, and care should be taken not

to alter the pressure, when adjusting, more than is absolutely necessary in order to obtain the desired results.

For fast sporting cars and for road and track racing, a considerable increase in pressure may, of course, be required.

When adjustment does become necessary, carefully note the riding qualities of the car, and if the spring action seems too retarded or stiff, reduce the frictional resistance of the shock absorbers by turning the centre adjusting nut to the left, or counter-clockwise, after slackening the lock nut. If the spring action seems too free, increase the frictional resistance by turning the adjusting nut to the right, or clockwise. After adjusting, tighten the lock-nut.

Careful adjustment in this manner will produce an ideal condition. The spring will still have the required amount of flexibility for easy riding, but spring vibration will be reduced to a minimum and violent rebound effectively eliminated.

The rear Austin shock absorbers do not require adjustment.

### Cleaning the Shock Absorbers

Periodically—especially in wet weather when much mud is thrown on to them—the large end of the shock absorbers should be taken apart, by withdrawing the centre bolt, and thoroughly cleansed. The centre pin and washers should then be slightly smeared with grease.

If this precaution is not adopted, the shock absorbers are liable to become tight—when an excessive load is thrown on the pins and bushes at the end of the arms, which will cause rapid wear. In addition, great strain is imposed on the bracket holding the shock absorber to the frame.

### Clutch Wear Take-up.

After the clutch has been in use for some time the wear of the friction surfaces will give rise to a need for adjustment in order to ensure the continued full engagement of the clutch.

The adjustment should be such as to allow at least  $\frac{3}{8}$  in. free movement of the clutch pedal with one finger. After depressing the pedal to this extent, the stronger resistance of the clutch springs will be obvious, so that it is easy to ascertain that the amount of free movement is correct. Lack of this free movement is serious, and does not permit the clutch to engage fully; it is of the utmost importance to maintain this free movement of the clutch pedal, and it should be inspected from time to time. Otherwise damage may be done to the clutch owing to the slipping of the plates.

The adjustment is obtained by **slightly** slackening the clamping screw at the bottom of the clutch pedal lever and depressing the pedal sufficiently to give the required free movement. The clamping screw must now be securely tightened and the adjustment checked.

## Clutch Slip

Some drivers are inclined to use the clutch instead of changing down to a lower gear, particularly when they are almost at the top of a hill and it is only necessary to change down for a few yards. Foot pressure is applied to the clutch to create a certain amount of slip (see page 10). This is a bad habit, it highly polishes the frictional surfaces and will eventually be the cause of persistent slip; finally in addition to burning out the fabric rings, probably also distorting the centre plate and making renewal of this essential.

Sometimes clutch slip is due to oil penetrating to the clutch as a result of overfilling the gearbox. If the inspection plate over the clutch casing is removed, petrol can be syringed on the clutch plate to wash off the oil, so that the clutch regains its frictional characteristics.

When injecting the petrol have the engine turned so that the plate is properly washed and the petrol and oil are given an opportunity to drain away, also push the clutch out and let it in by the pedal so that the petrol is given a washing action. Do not replace the inspection plate, until the oil and petrol have had sufficient time to evaporate, or be drawn off through a hole in the casing under the flywheel. See that this hole is clear.

After this operation it is advisable to lubricate the declutching levers at their pivoting points and the clutch withdrawal collar (page 40) as the lubricant in these members may have been removed by the petrol.

## Fan Adjustment

Release the clamping pin nut on the fan bracket and then turn the spindle, which is in the form of a crank, until the necessary tension is obtained in the fan belt.



# CARE OF THE HOOD

## Lowering the Hood of the Tourer.

To lower the hood, first release it from the pillars of the windscreen, push the side screens inwards so that the rubber buffers fixed near the top of the division on the side screens clear the iron framework of the hood.

Now push the hood straight up and back from the front and break the joint of the iron framework, which is the commencement of the "concertina" movement which begins the actual lowering of the hood.

The hood will then collapse towards the back of the car. Pull the folds out until they lie in one big fold over the back of the car; fix the hood frame to the hood rest on the body by means of the fasteners on the strap at the front end of the hood, secure the two rear window fasteners on to the two studs at the back of the body, but if the hood cover is used, then the two straps on the hood cover will clip on to these two studs instead of the rear window fasteners. Ensure that the folded frame rests in the support near the forward end of the lowered upright that pivots on the body.

Now fold the material back carefully, seeing that the edges are evenly placed, turn them in, either side or under, and put the cover in position over all.

Finish by securing the cover by the straps, one on each side.

## Raising the Hood of the Tourer

To raise the hood, remove the cover, release the clip, and unfold the hood material. Lift the top hood stick vertically, holding the metal side-strip of the hood frame near the hinge. If the front hood stick is then pushed forward and the metal strips are pulled back to straighten the hinge, the whole hood can be dropped forward and secured in position to the windscreen.

## Care of the Hood

Care should be taken in folding down the hood to see that the original folds are used. Should the car have been used in wet weather leave the hood up to dry. Never fold it when wet.

## The Cabriolet Roof

To lower the roof on the Austin Seven Pearl Cabriolet, the following procedure should be adopted: Release the two fastenings above the windscreen (one is shown at A in Fig. 1) and lift the canopy rod. Then detach the three clips which secure the front bar on which the fabric is carried. Roll back the fabric as far as it will go, turning the material over and securing the roll (as in Fig. 2) by fastening the loop provided at each side of the top stud of each roof stretcher (as at B). Pull the two arms (C and D) of each roof stretcher in the direction of the arrows to break the joint and fold the rear portion of the hood down (Fig. 3); then swing forward the hinged roof-bar (E), and secure the rear window by its two

fasteners to the top of the folded roof member. It should be noted that the roof stretcher joints must not be broken before the front of the roof fabric is released from the canopy rod. Raising the roof is a reversal of the above operations. In lifting the roof members to the door pillars ensure that the locating dowel enters the hole in each pillar (as at F and G in Fig. 3).

This roof can be left rolled back at the partially open position shown in Fig. 2 if desired, but it should not be fully or partially lowered while wet.

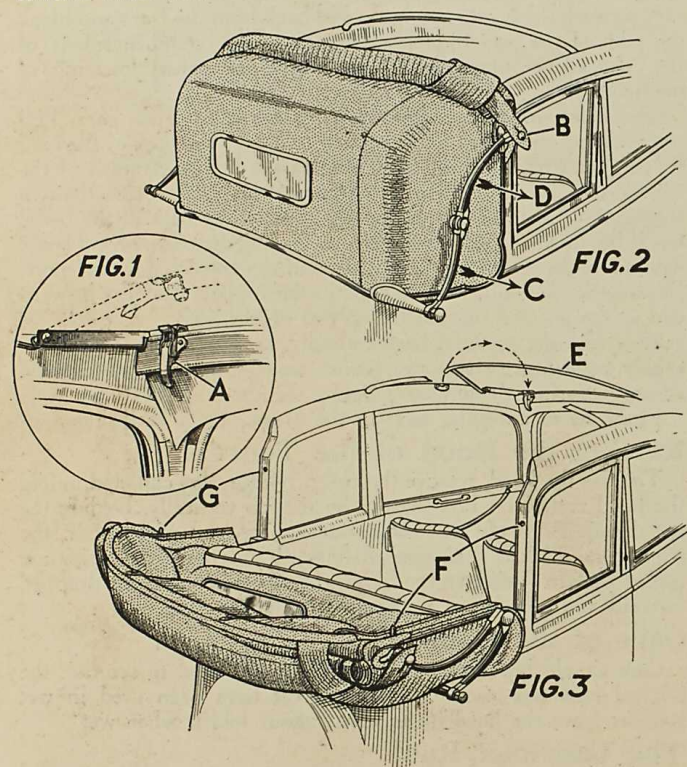

The first operation (Fig. 1) in lowering the Seven Cabriolet hood is to release the front hinged member from the front of the body by releasing Clip A. Then the head fabric can be rolled back and fastened as shown at B in Fig. 2. Next the stretcher joint is broken by pulling in the direction of the arrows C and D, and when the head is down the bar E in Fig. 3 can be swung forward. F and G are the dowels and holes which must locate when the head is re-erected.

### The Side Curtains

The side curtains are secured against movement or rattle by set screws. The pegs at the bottom of the curtains fit into holes in the aluminium rail on the top of the bodywork, and these pegs are firmly held by screws. Before the sidescreens can be removed, these screws must be slacked with a coin or screwdriver, and also the nut on the inner side of the main hood stick fulcrum.

Provision has now been made to carry the side screens in a recess at the back of the rear squab, where they are safe from injury when not in use.

First loosen the screws which secure the pegs firmly to the body and doors, then lift out the side screens.

Unfasten the strap at the top of the squab, pull the back seat cushions forward, and lift out the squab.

The rear curtains are dealt with first. Their pegs go into the slots. Then the front curtains are put away; their pegs fit into the round holes.

The hinges on all the screens should be toward the side of the car.

The nearside curtains are stowed on the nearside of the compartment. Replace the squab, fasten the press stud on the strap, and push the seat cushion into its proper position.

### Float-on-Air Seat Interiors

The essence of comfort with "Moseley Float-on-Air" upholstery is low pressure—to blow up the cushions at all hard is to destroy their powers of absorbing vibration. The seat should be quite soft to the touch, the hand pressed on the surface sinking well in. If the seats do not give perfect results release air from the valve, as the usual fault is over inflation. The butt ended portion running round the sides and front of each interior is separately inflated and should be moderately well blown up. The centre portion of each interior is also separately inflated, and the pressure should be such that the base of the seat can be felt when pressed with the closed fist. This gives the ideal pressure and support when sat upon.

To adjust the air pressure open the flap at the rear of the cushion, exposing the valves. The valve at the side inflates the "butt ended portion" above referred to; the other valve (or valves in the rear cushion) inflates the centre section. Draw gently on the tabs till the rubber valve protrudes about one inch, do not pull hard otherwise the valve may be damaged. Roll back the rubber ring towards the cushion when the plug can be readily removed from the tube. Blow with the mouth or release air as required.

Moisten the plug and reinsert as far as it will go, roll ring back until it engages in the depression caused by slot in plug. Push back the valve till the cap is flush with the surface and refasten the flap.

### Storing the Car

Should the car be laid up in the garage for long periods, the fuel and water should be drained off and the batteries removed, and weight taken off the tyres.

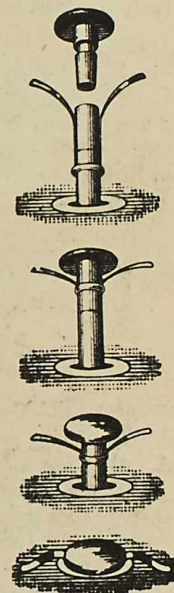

## CARE of the BODYWORK

FOR the car to look well and keep its beauty and smart appearance, the body must be given its share of attention; it must not be neglected.

### Washing

The cellulose finish of the car is easily cleaned and polished. In summer weather when the car is only dusty the dust can be lightly flicked off without water and there is no risk of damaging the finish. When the car is muddy, wash off well with clean running water—wash the mud off—don't rub it off. Remove any grease or tar splashes with petrol. Don't use the same sponge and cleaning cloths for the chassis and springs and other greasy parts as are used for the coachwork.

### Polishing

Dry off and then polish with one of the special polishes now marketed. Such preparations impart a brilliant surface and preserve and beautify the body. On no account should metal polishes be used, as are sometimes advertised for cellulose. It has been found that the more the surface of the cellulose finish is rubbed by the polishing cloth, the smoother and more lasting is the lustre imparted.

Door locks, hinges and other small working parts should be given a drop or two of oil occasionally.

## DON'T !

Don't, *please* don't—

Don't leave the car in gear with the handbrake off.

Don't make a fast run with the radiator muff down.

Don't fill the radiator with cold water when the engine is hot.

Don't try to turn the engine without first pushing the starting-handle in to engage fully with the starting nut.

Don't be cruel to the starter if the engine will not fire.

Don't put an excessive quantity of lubricant in the gear box.

Don't forget the ignition key when starting up.

Don't forget to withdraw the ignition key when the engine is not running.

Don't coast with the engine running and the clutch held out.

Don't run the engine in a closed garage. (The exhaust gases are highly toxic and a very small amount in a restricted atmosphere will produce grave, if not fatal, results).

All Austin Dealers carry stocks of genuine Austin replacements, and applications for spare parts should be made to them. Clients will then be certain that the replacements are made by parts manufactured by The Austin Motor Company and carrying their high reputation for quality and workmanship.

## TOOLS and ACCESSORIES SUPPLIED WITH THE CAR.

The tools are supplied in a sealed cardboard box. The owner should see the seals are intact when the car is delivered.

The tools should be carefully checked against the list shown at the end of the handbook, then put into their places in the wraps, and stowed away in the car.

$\frac{1}{2}$  in. and  $\frac{3}{8}$  in. box spanner.

$\frac{5}{8}$  in. and  $\frac{3}{4}$  in. box spanner.

$\frac{3}{8}$  in. and  $\frac{1}{2}$  in. box spanner.

$\frac{3}{8}$  in. and  $\frac{1}{2}$  in. double open-end spanner.

$\frac{5}{8}$  in. and  $\frac{3}{4}$  in. double open-end spanner.

$\frac{7}{8}$  in. and  $\frac{1}{2}$  in. double open-end spanner.

Adjustable spanner, 4 in.

Hub-cap and steering column sleeve spanner.

Distributor Screwdriver and Gauge.

Tappet adjusting spanner.

2 Radiator hose clips.

1 Extra ignition key.

Spanner for monobloc nuts.

Tool wrap.

Sparking-plug box spanner and tommy bar.

Brace for detachable wheels.

Tyre lever.

Tyre pump.

Lifting jack, with handle.

Screwdriver.

Sparking plug and tappet clearance gauge.

Grease gun with adaptor.

Valve-spring lifter.

Combination pliers.

Hub extractor and screw.

A spare cylinder-head joint washer is also supplied.

Extra with sports model: Valve grinding tool.

# The Austin Magazine

contains many useful hints designed to help the owner driver to perform "those little attentions that mean so much" toward getting the best from his car.

Also there are detailed descriptions of the bigger jobs that can be safely tackled at home, explained in simple language and suitably illustrated.

*There are special features, interesting stories by popular authors, travel and sports articles "and motoring miscellanea."*

**Your Newsagent will deliver the Magazine to you for 4d. per month.**

## STANDARD REPAIR CHARGES

THE following adjustments and repairs described in this handbook are included in the Austin Seven Schedule of Charges for Repairs, which quotes over one hundred prices for repairs to the Austin Seven.

Greasing spring shackles, steering and brake, and other small connections.

Ditto, but including rear axle, universal joint, steering box and front hubs.

Taking down, cleaning and greasing all road springs, reassembling with new bolts and bushes where required.

Dismantling shock absorbers, then cleaning and adjusting and refixing.

Adjusting and compensating brakes.  
Relining brakes, front or rear.

Removing cylinder head; decarbonising and grinding in valves, adjusting tappets and tuning-up engine on the road.

Fitting new cylinder head and/or gasket.

Adjusting valve tappets, cleaning and adjusting contact breaker, distributor and sparking plugs; cleaning out carburetter jets.

Fitting new valves.

Removing base chamber, cleaning oil filter, examining interior of engine, and refilling with new oil.

Removing dynamo from car; cleaning and adjusting, examining battery and connections, and refilling battery with acid as required.

Tracking up front wheels by adjusting length of cross steering tube.

Owners will find it to their advantage to have their car adjustments and repairs effected by Austin agents at these standard prices.

## AUSTIN SEVEN EQUIPMENT

---

**T**HE Austin Motor Co., Ltd., accept no liability under the terms of their Warranty for Tyres, Speedometers, or the Electrical Equipment, or other goods, including Coachwork, not of their own Manufacture.

All claims relating to any of these parts or fittings or orders for repairs to them, should be addressed to their manufacturers.

For owners' information we give below the names and addresses of the manufacturers, or suppliers of the equipment fitted on the Austin Seven.

### IMPORTANT

When claims under guarantee are being made, it is absolutely necessary to quote the type and number of the car, and the commissioning date.

#### Electrical and Ignition Equipment, Lamps and Batteries

"Lucas" Joseph Lucas, Ltd., Great Hampton Street,  
and Birmingham and Dordrecht Road, Acton  
"C.A.V." Vale, London, W.3.

#### Windscreen Wiper

"Lucas" Joseph Lucas, Ltd., Great Hampton Street,  
Birmingham and Dordrecht Road, Acton  
Vale, London, W.3.

#### Grease Gun

"Enots" Benton and Stone, Ltd., Bracebridge Street  
Birmingham.

#### Speedometer

"Smith" S. Smith and Sons (M.A.), Ltd., Cricklewood  
Works, London, N.W.2.

#### Tyres and Tubes

"Dunlop" Dunlop Rubber Co., Ltd., Fort Dunlop  
Erdington, Birmingham.

#### Carburetter

"Zenith" Zenith Carburetter Co., Ltd., 40-42, Newman  
Street, London, W.1.

#### Horns

"A.R." A. Rist, Ltd., Waveney Works, Lowestoft.

#### Lifting Jacks

R. T. Shelley, Ltd., Aston Brook Street,  
Birmingham.

#### Petrol Pump

"A.C." Sphinx Sparking Plug Co., Dunstable.

---

*Owner's Name*

*Address*

*Car No.*

*Registration No.*

*Driving Licence No.*

*Insurance Policy No.*

## "LUCAS" SERVICE DEPOTS

- BELFAST, 3-5, Calvin Street, Mountpottinger.  
Telegrams: "Servdep," Belfast. Telephone: Belfast 8811/13.
- BIRMINGHAM, 18, Great Hampton Street.  
Telegrams: "Lucas, Birmingham." Telephone: Central 8401  
(10 lines)
- BRIGHTON, 4, 85, Old Shoreham Road, Hove.  
Telegrams: "Luserv Brighton." Telephone: Hove 1146/49
- BRISTOL, 345, Bath Road.  
Telegrams: "Kingly, Bristol." Telephone: Bristol 76001  
(4 lines)
- CARDIFF, 54a, Penarth Road.  
Telegrams: "Lucas, Cardiff." Telephone: Cardiff 4603  
(4 lines)
- COVENTRY, Priory Street.  
Telegrams: "Lucas, Coventry." Telephone: Coventry 3068
- DUBLIN, Portland Street North, North Circular Road.  
Telegrams: "Luserv, Dublin." Telephone: Drumcondra 434  
(6 lines)
- EDINBURGH, 11, 60, Stevenson Road, Gorgie.  
Telegrams: "Luserv, Edinburgh." Telephone: Edinburgh 62921  
(4 lines)
- GLASGOW, 227-229, St. George's Road.  
Telegrams: "Lucas, Glasgow." Telephone: Douglas 3075  
(5 lines)
- LEEDS, 64, Roseville Road.  
Telegrams: "Luserdep, Leeds." Telephone: Leeds 28591  
(5 lines)
- LIVERPOOL, 13, 450-456, Edge Lane.  
Telegrams: "Luserv, Liverpool." Telephone: Old Swan 1408  
(4 lines)
- LONDON, Dordrecht Road, Acton Vale, W.3.  
Telegrams: "Dynomagna, Ealux, London."  
Telephone: Shepherds Bush 3160 (10 lines).
- LONDON, 757-759, High Road, Leyton, E.10.  
Telegrams: "Luserdep, Leystone, London."  
Telephone: Leytonstone 3361 (4 lines).
- LONDON, 155, Merton Road, Wandsworth, S.W.18.  
Telegrams: "Luserv, Put, London."  
Telephone: Putney 5131 (6 lines) and 5501.
- MANCHESTER, 3, Talbot Road, Stretford.  
Telegrams: "Lucas, Stretford." Telephone: Longford 1101  
(5 lines)
- NEWCASTLE-ON-TYNE, 2, 64-66, St. Mary's Place.  
Telegrams: "Motolite, Newcastle-on-Tyne."  
Telephone: Newcastle: 25571 (3 lines).  
In addition, there are Lucas-C.A.V.-Rotax Official Battery Service  
Agents in important centres throughout the country.

*[Handwritten notes and diagrams in blue ink on the right page, including numbers and lines.]*

REB To P

$$\begin{array}{r}
 344006 \\
 133 \text{ full} \\
 \underline{\quad 3} \\
 20 \quad 3996 \\
 \underline{\quad 18.19}
 \end{array}$$

19.0.0

5.0.0

2.0.0

12.0

10.0

1.15.0

28.17.0

~~20.0.0~~

~~29.0.0~~

~~51~~

~~10~~

~~31.0.0~~

~~12~~

~~30.0.0~~

~~5.0.0~~

25.0.0

~~3.5.0~~

$$\begin{array}{r}
 63 \\
 \underline{16}
 \end{array}$$

10.5.1

15.12.11

13.15.00

15.0.0

13.10.3

~~11.6.0~~

66

90



